

Rationale for Ballot 2020-R1:

This is a recirculation ballot to Committee Ballot 2020-C1 (issued 01/02/20 and closed 02/03/20). The tracked changes in this ballot are relative to **Ballot 2020-C1**.

Ballot 2020-C1 received no negative votes except for some comments. The Executive Subcommittee carefully reviewed all comments and developed a response to each comment, as attached. However, due to some non-editorial changes required to address the comments, this recirculation ballot is issued to afford all members of the Committee an opportunity to respond, reaffirm, or change their vote. See the ballot instruction for recirculation ballot on the attached ballot form.

All changes that have been approved by Ballot 2020-C1 are shown in the underline (new text) and ~~strike-out~~ (deleted current text) format. For this recirculation ballot, additional changes made to Ballot 2020-C1 in response to comments received from the last ballot are further highlighted in **blue** (pages 6, 7, 11, 13, 23, 26, 27, 38, and 50).

###

AMERICAN NATIONAL STANDARD

Approval of an American National Standard requires review by ANSI that the requirements for due process, consensus, and other criteria for approval have been met by the standards developer. Consensus is established when, in the judgment of the ANSI Board of Standards Review, substantial agreement has been reached by directly and materially affected interests. Substantial agreement means more than a simple majority, but not necessarily unanimity. Consensus requires that all views and objections be considered, and that a concerted effort be made towards their resolution. The use of American National Standards is completely voluntary; their existence does not in any respect preclude anyone, ~~whether he has approved the standards or not,~~ from manufacturing, marketing, purchasing, or using products, processes, or procedures not conforming to the standards.

The American National Standards Institute does not develop standards and will in no circumstances give an interpretation of any American National Standard. Moreover, no person shall have the right or authority to issue an interpretation of an American National Standard in the name of the American National Standards Institute. Requests for interpretations should be addressed to the secretariat or sponsor whose name appears on the title page of this standard.

Caution Notice: This American National Standard may be revised or withdrawn at any time. The procedures of the American National Standards Institute require that action be taken periodically to reaffirm, revise, or withdraw this standard. Purchasers of American National Standards may receive current information on all standards by calling or writing the American National Standards Institute.

American National Standards Institute
25 West 43rd Street, 4th Floor
New York, NY 10036
www.ansi.org

Published by APA – *The Engineered Wood Association*
7011 South 19th Street
Tacoma, WA 98466

Copyright © ~~2015~~-2020 by APA – *The Engineered Wood Association*
All rights reserved.

No part of this publication may be reproduced in any form, in an electronic retrieval system or otherwise, without the prior written permission of the publisher.

~~Printed in the United States of America~~

FOREWORD (This Foreword is not a part of American National Standard ANSI 117-~~2015~~2020)

This Standard is ~~an American National Standard previously designated as a revision of American National Standard~~ ANSI 117-~~2010~~2015. It contains information for the design of structural glued laminated timber (glulam) members.

Since January 1, 2013, *APA – The Engineered Wood Association* has assumed the Secretariat responsibilities for this Standard. The maintenance of this Standard follows the *Operating Procedures for Development of Consensus Standards of APA – The Engineered Wood Association*, approved by ANSI.

Inquiries or suggestions for improvement of this standard are welcome and should be directed to *APA – The Engineered Wood Association* at 7011 South 19th Street, Tacoma, WA 98466, www.apawood.org.

CONTENTS

(Secretariat Notes: The table of contents will be editorially updated and formatted when the standard is approved and published)

FOREWORD

1. SCOPE

2. REFERENCED DOCUMENTS

3. BASIC REQUIREMENTS

4. REFERENCE DESIGN VALUES

5. LAYUP REQUIREMENTS

6. ALTERNATE COMBINATIONS

ANNEX A DESIGN VALUE TABLES FOR STRUCTURAL GLUED LAMINATED SOFTWOOD TIMBER

ANNEX B LAYUP REQUIREMENTS FOR STRUCTURAL GLUED LAMINATED SOFTWOOD TIMBER

ANNEX C LAMINATING LUMBER GRADING RULES FOR STRUCTURAL GLUED LAMINATED TIMBERS

APPENDIX X1 HISTORY OF STANDARD (NON-MANDATORY)

PREFACE 1. SCOPE

The term *structural glued laminated timber* (glulam) as used herein refers to an engineered, stress-rated product of a timber laminating plant, comprising assemblies of suitably selected and prepared wood laminations bonded together with adhesives. The grain of all laminations is approximately parallel longitudinally. Glulam is permitted to be comprised of pieces end joined to form any length, of pieces placed or bonded edge to edge to make any width, face glued to form any depth, or of pieces bent to curved form during bonding.

This Specification contains values for the design of structural glued laminated timber members. It is, however, intended to be neither a design manual nor an engineering textbook. Structural design of glued laminated timber members and their fastenings shall be in accordance with the National Design Specification® (NDS®) for Wood Construction ~~(15)~~.

Section ~~1-3~~ of this Specification (*Basic Requirements*) identifies characteristics of importance to the use of structural glued laminated timber and provides general information useful to the manufacturer and designer.

Section ~~2-4~~ (*Reference Design Values*) provides and describes reference design values for use in the design of structural glued laminated timber. The reference design values require adjustment by procedures detailed in the NDS.® The design values described herein are for use with the Allowable Stress Design (ASD) methodology. For Load and Resistance Factor Design (LRFD), conversion formulas for design values are provided in the NDS.® The design values of glued laminated timber used in utility structures can be obtained by multiplying the reference design values provided in this Specification by the conversion factors specified in ANSI O5.2 ~~(4)~~.

Specific ~~lay-up~~layup requirements are provided in Section ~~3-5~~ of this Specification (*Lay-up*Layup Requirements). The production of structural glued laminated timber under this Specification shall be in accordance with American National Standard ANSI A190.1 *Structural Glued Laminated Timber* ~~(3)~~.

Combinations not listed in this Specification are permitted to be used provided that all other requirements of this Specification are met. Specific requirements for alternate combinations are included in Section ~~4-6~~ of this Specification (*Alternate Combinations*).

The annexes contained in this standard are mandatory, while notes and appendix are non-mandatory. This standard incorporates the U.S. customary units as well as the International System of Units (SI). The values given in the U.S. customary units are the standard and the SI values given in parentheses are for information only. In case of a dispute on size measurements, the U.S. customary method of measurement shall take precedence.

2. REFERENCED DOCUMENTS

This standard incorporates dated references. Subsequent amendments or revisions to these references apply to this standard only when incorporated into this standard by amendments or revisions.

2.1 U.S. Standards

ANSI A190.1-2017 American National Standard for Wood Products—Structural Glued Laminated Timber

ANSI O5.2-2012 American National Standard for Wood Products—Structural Glued Laminated Timber for Utility Structures

ANSI/AWC NDS-2018 National Design Specification for Wood Construction

ASTM D143-14 Standard Test Methods for Small Clear Specimens of Timber

ASTM D2395-17 Standard Test Methods for Density and Specific Gravity (Relative Density) of Wood and Wood-Based Materials

ASTM D2915-17 Standard Practice for Sampling and Data-Analysis for Structural Wood and Wood-Based Products

ASTM D3737-18e1 Standard Practice for Establishing Allowable Properties for Structural Glued Laminated Timber (Glulam)

ASTM D4442-16 Standard Test Methods for Direct Moisture Content Measurement of Wood and Wood-Based Materials

ASTM D4444-13(2018) Standard Test Method for Laboratory Standardization and Calibration of Hand-Held Moisture Meters

ASTM D4761-19 Standard Test Methods for Mechanical Properties of Lumber and Wood-Based Structural Materials

ASTM D7341-14 Standard Practice for Establishing Characteristic Values for Flexural Properties of Structural Glued Laminated Timber by Full-Scale Testing

ASTM D7438-13 Standard Practice for Field Calibration and Application of Hand-Held Moisture Meters

ASTM D7469-16 Standard Test Methods for End-Joints in Structural Wood Products

2.2 References

AITC Timber Construction Manual, 2012

AITC Test Methods for Structural Glued Laminated Timber, 2007

AITC/WCLIB 200 Manufacturing Quality Control Systems Manual, 2009

APA Quality Assurance Policy for Structural Glued Laminated Timber, 2015

National Lumber Grades Authority (NLGA) Standard Grading Rules for Canadian Lumber, 2017

Redwood Inspection Service (RIS) Standard Specifications for Grades of California Redwood Lumber, 2019

Northeastern Lumber Manufacturers Association (NELMA) Standard Grading Rules for Northeastern Lumber, 2017

Southern Pine Inspection Bureau Southern Pine Inspection Bureau Grading Rules, 2014

West Coast Lumber Inspection Bureau Standard No. 17 Grading Rules for West Coast Lumber, 2018

Western Wood Products Association Western Lumber Grading Rules, 2017

13. BASIC REQUIREMENTS

13.1 General

Structural glued laminated timber conforming to this Specification shall be produced in laminating plants audited and licensed by an accredited inspection agency meeting the requirements of ANSI A190.1-~~(3)~~. Quality assurance for workmanship and materials shall be the responsibility of the manufacturer's quality control operations. The manufacturer's quality control systems shall be subject to periodic auditing by the accredited inspection agency. Timbers conforming to this Specification shall be marked according to ANSI A190.1-~~(3)~~.

Structural glued laminated timbers are permitted to be made up of a single grade of lumber or multiple grades placed with specific quantities in specific zones within the cross-section. Structural glued laminated timber combinations generally utilize higher grade lumber in the outer zones than in the center of the beam or core. Design values for structural glued laminated timbers are established according to the analysis procedures of ASTM D3737-~~(9)~~ or through full scale tests in accordance with ASTM D7341-~~(13)~~ and analysis in accordance with ASTM D2915-~~(8)~~.

13.2 Species

Structural glued laminated timber can be manufactured from any suitable wood species. Wood species with similar properties are grouped for convenience. Design properties and ~~lay-up~~layup information are included in this Specification for structural glued laminated timbers of the following species groups:

Species Group	Symbol	Species that may be included in the group
Alaska Cedar	AC	Alaska Cedar
Douglas-Fir-Larch	DF	Douglas-Fir, Western Larch
Eastern Spruce	ES	Black Spruce, Red Spruce, White Spruce
Hem-Fir	HF	California Red Fir, Grand Fir, Noble Fir, Pacific Silver Fir, Western Hemlock, White Fir
Port Orford Cedar	POC	Port Orford Cedar
Softwood Species	SW	Alpine Fir, Balsam Fir, Black Spruce, Douglas Fir, Douglas Fir South, Engelmann Spruce, Idaho White Pine, Jack Pine, Lodgepole Pine, Mountain Hemlock, Norway (Red) Pine, Norway Spruce (N)^(b) , Ponderosa Pine, Sitka Spruce, Sugar Pine, Red Spruce, Western Larch, Western Red Cedar, White Spruce
Southern Pine	SP	Loblolly Pine, Longleaf Pine, Shortleaf Pine, Slash Pine
Spruce-Pine-Fir ^(a)	SPF	Alpine Fir, Balsam Fir, Black Spruce, Engelmann Spruce, Jack Pine, Lodgepole Pine, Norway (Red) Pine, Norway Spruce^(c) , Red Spruce, Sitka Spruce, White Spruce

(a) Including Spruce-Pine-Fir and Spruce-Pine-Fir (South).

(b) [Norway Spruce \(N\) grown in Canada](#).

(c) [Norway Spruce grown in the U.S., as part of Spruce-Pine-Fir \(South\)](#).

Other species or species groups are permitted to be used in accordance with ANSI A190.1-~~(3)~~.

13.3 Combination Symbols

Each structural glued laminated timber ~~lay-up~~layup is assigned a combination symbol. The combination symbol is used to identify a combination and to distinguish one combination from another. Each combination is assigned design values based on ASTM D3737-~~(9)~~ or full-scale tests in accordance with ASTM D7341-~~(13)~~. Design values for combinations are tabulated in *Annex A*. ~~lay-up~~layup requirements for combinations are tabulated in *Annex B*. The combination symbols in *Table A1-Expanded* indicate the primary design bending stress and the grading system used for the lumber in the outer zones. For example, 24F-V4 indicates that the beam has a primary bending design value of 2400 psi (16.6 MPa) and that the lumber in the outer zones was visually graded. 24F-E13 indicates that the bending design value is 2400 psi (16.6 MPa) and the lumber in the outer zones was

E-rated using a mechanical grading system in addition to visual requirements. The number at the end of the combination symbol (13 in this example) is a number assigned to distinguish between different combinations. The species group(s) used in the beam is also included as part of the combination symbol. The first species group listed corresponds to the laminations in the outer zones of the ~~lay-up~~layup, and the subsequent species group is for the laminations used in the interior zones.

The combination symbols for ~~lay-up~~layups in *Table A2* are numbers which have been assigned for specification purposes. Each combination symbol corresponds to a specific grade of lumber used in a uniform grade ~~lay-up~~layup.

13.4 Stress Classes

To simplify specification, combinations from *Table A1-Expanded* with similar design stresses have been grouped into stress classes. These stress classes are recommended for specification purposes rather than specifying by combination symbol. Use of the stress class system allows manufacturers flexibility in choosing combinations that make efficient use of their available resources and simplifies the design process. These stress classes are shown in *Table A1*.

Stress classes are designated by primary bending stress and modulus of elasticity. To qualify for a stress class, combinations are required to have design values that meet or exceed all values listed for the stress class. Each combination qualifying for a stress class also qualifies for all lower stress classes.

Because the stress classes are not species-group-specific, it is critical that the designer specify when a particular species is required for appearance reasons or other considerations. Some stress classes are not available in all species. *Table A1-Expanded* lists combinations included in each stress class.

13.5 Balanced or Unbalanced ~~lay-up~~Layups

Structural glued laminated timbers are permitted to be manufactured with lumber grades placed symmetrically or asymmetrically about the neutral axis of the member. Timbers with symmetric ~~lay-up~~layups are referred to as “balanced” and have the same design values for positive and negative bending. Timbers with asymmetric ~~lay-up~~layups are referred to as “unbalanced” and have higher design stresses for positive bending than for negative bending. Unbalanced ~~lay-up~~layups are generally used for simple, single-span beams, while balanced ~~lay-up~~layups are used for continuous or cantilevered beams. Unbalanced combinations are permitted to be used as continuous or cantilevered beams, provided that the stresses due to negative moment do not exceed the tabulated bending design value modified by applicable adjustment factors. The top side of straight or cambered beams is required to be marked “TOP” by the manufacturer to facilitate proper installation.

13.6 Adjusted Design Stresses

Reference design stresses for structural glued laminated timber are based on standard conditions and must be modified for expected end-use conditions by applying adjustment factors from the NDS® ~~(15)~~. The reference design stress multiplied by all applicable adjustment factors is referred to as the “adjusted design stress.” The reference design values are discussed in Section ~~24~~.

13.7 Standard Sizes

ANSI A190.1 ~~(3)~~ permits the use of any width or depth of structural glued laminated timber. The use of standard finished sizes constitutes recommended practice to the extent that other considerations will permit. The depth and width of the timber shall be as agreed upon by the buyer and seller. All members shall be sized in accordance with the width, depth, and length requirements of the structural design. Dimensional tolerances shall be in accordance with ANSI A190.1 ~~(3)~~.

Standard net finished widths for structural glued laminated timbers are as shown in Table 31.7.

TABLE 31.7
STANDARD NET FINISHED WIDTHS FOR STRUCTURAL GLUED LAMINATED TIMBER

Nominal Width of Laminations	Softwoods Other Than Southern Pine Net Width (in.)	Southern Pine Net Width (in.)
3	2-1/8 (55-54 mm) or 2-1/2 (65-64 mm)	2-1/8 (55-54 mm) or 2-1/2 (65-64 mm)
4(a)	3-1/8 (80-79 mm)	3 (75-76 mm) or 3-1/8 (80-79 mm)
6(a)	5-1/8 (130 mm)	5 (125-127 mm) or 5-1/8 (130 mm)
8	6-3/4 (170-171 mm)	6-3/4 (170-171 mm)
10	8-3/4 (220-222 mm)	8-1/2 (215-216 mm)
12	10-3/4 (275-273 mm)	10-1/2 (265-267 mm)
14	12-1/4 (310-311 mm)	12 (305 mm)
16	14-1/4 (360-362 mm)	14 (355-356 mm)

(a) Standard widths for structural glued laminated timber meeting the requirements of the Framing appearance grade are 3-1/2 in. (89 mm) for nominal 4 in. lamination width and 5-1/2 in. (140 mm) for nominal 6 in. lamination width.

Standard depths are in multiples of the standard lamination thickness. Southern pine laminations are typically surfaced to 1-3/8 inches (35 mm) thick, and laminations of other softwood species are typically surfaced to 1-1/2 inches (38 mm) thick. Laminations 3/4 inch (19 mm) thick are often used for curved members of both southern pine and western species. Depths matching standard I-joist depths are also available from many manufacturers.

31.8 Shapes

Structural glued laminated timbers ~~can be~~ manufactured in a variety of shapes from straight beams to curved arches. Members ~~can be~~ also ~~be~~ manufactured with tapered or constant cross section.

NOTE 1:

~~1.8.1~~ For curved members manufactured with nominal 2-inch thickness laminations, the recommended minimum radius of curvature (at the inside face) is 18 feet (5.5 m) for southern pine and 27 feet 6 inches (8.4 m) for other softwood species.

~~1.8.2~~ For tudor arches and other tightly curved members manufactured with nominal 1-inch thickness laminations, the recommended minimum radii of curvature (at the inside face) are:

7 feet 0 inch (2.1 m)* for southern pine (see Note 2)

9 feet 4 inches (2.8 m)* for all other softwood species (see Note 2)

NOTE 2: *The manufacture of curved members with radii shorter than these requires standard thickness laminations to be planed to a thinner dimension resulting in more waste and less efficient use of materials. It is recommended that the designer contact the laminator prior to specifying radii shorter than those listed above. For thin laminations, the radius ~~shall~~ should not be less than 100 times the lamination thickness for southern pine or 125 times the lamination thickness for other softwoods.

31.9 Appearance Grades

Appearance grades shall be specified in accordance with ANSI A190.1-~~(3)~~ or as agreed upon between buyer and seller. The reference design values are independent of the appearance grades. Special surfacing, such as rough saw texturing, may reduce the cross section and may affect the member capacity based on the reduced section properties. The reduced cross section (if applicable) shall be considered in design.

24. REFERENCE DESIGN VALUES

24.1 General

Design values for structural glued laminated timber are dependent on the orientation of the member relative to the applied loads. Values designated with a subscript “x” are based on transverse loads applied perpendicular to the wide faces of the laminations, causing bending about the x-x axis (Figure 24.1-1). Values designated with a subscript “y” are based on transverse loads applied parallel to the wide faces of the laminations, causing bending about the y-y axis (Figure 24.1-1).

Design values are tabulated for bending (F_{bx+} , F_{bx-} , F_{by}), compression perpendicular to grain ($F_{c\perp x}$, $F_{c\perp y}$), shear (F_{vx} , F_{vy}), modulus of elasticity (E_x , E_y), tension parallel to grain (F_t), and compression parallel to grain (F_c). Also tabulated are specific gravity values and species groups for use in connection design. Values are not tabulated for torsion, for modulus of rigidity, or for radial stresses in curved bending members, because these values can be determined from other tabulated design values.

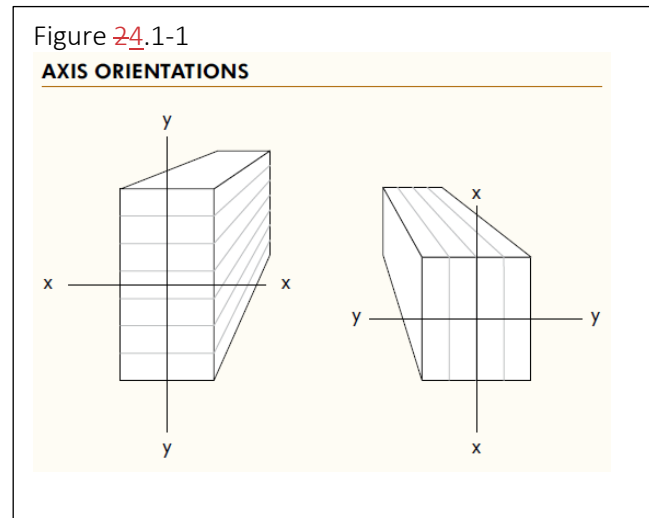

24.2 Bending Design Values, F_{bx+} , F_{bx-} , F_{by}

Tabulated design values are provided for positive bending of horizontally laminated timbers (F_{bx+}), negative bending of horizontally laminated timbers (F_{bx-}), and bending of vertically laminated members (F_{by}). Horizontally laminated members have bending loads applied perpendicular to the wide faces of the laminations. Vertically laminated members have bending loads applied parallel to the wide faces of the laminations. Positive bending causes tensile stresses at the bottom of a beam. Negative bending causes compressive stresses at the bottom of a beam.

24.3 Compression Perpendicular to Grain Design Values, $F_{c\perp x}$, $F_{c\perp y}$

The use of multiple laminating grades results in different design values in compression perpendicular to grain for the top and bottom and for the side faces of a beam. One value is tabulated for use in bearing on the top or bottom of the beam and one value is tabulated for side bearing to simplify design.

The tabulated compression perpendicular to grain design values are based on a deformation limit of 0.04 inch (1 mm) obtained when tested in accordance with ASTM D143-~~6~~. A compression perpendicular to grain design value based on a 0.02 inch (0.5 mm) deformation limit can be estimated as 73% of the tabulated value.

$E_{x \min}$, $E_{y \min}$, and $E_{axial \min}$ are calculated using the following formula:

$$E_{min} = \frac{E_{app}(1 - 1.645 CoV_E)(1.05)}{1.66} = \frac{E_{app}[1 - 1.645(0.10)](1.05)}{1.66} = 0.528 E_{app}$$

where: E_{min} = $E_{x \min}$, $E_{y \min}$, or $E_{axial \min}$ as appropriate

E_{app} = $E_{x \text{ app}}$, $E_{y \text{ app}}$, or $0.95 E_{axial}$ as appropriate

CoV_E = coefficient of variation for modulus of elasticity

24.6 Tension Parallel to Grain Design Value, F_t

A single design value is tabulated for tension parallel to grain for each combination or stress class.

24.7 Compression Parallel to Grain Design Value, F_c

A single design value is tabulated for compression parallel to grain for each optimized combination or stress class. Uniform grade combinations have separate values tabulated for members with 2 or 3 laminations and for members with 4 or more laminations.

24.8 Radial Compression Design Values, F_{rc}

The design value for radial compression, F_{rc} , shall be equal to the design value for compression perpendicular to grain of the side faces, $F_{c\perp y}$.

24.9 Radial Tension Design Values, F_{rt}

For southern pine, the design value for radial tension (tension perpendicular to the longitudinal axis of a curved member), F_{rt} , shall be equal to 1/3 of the shear design value, F_{vx} , for non-prismatic members. Radial reinforcement shall not be required.

For all other softwood species, the reference design value for radial tension shall be limited to 15 psi (100 kPa) for loads other than wind or earthquake loads. If the calculated radial tension stress (due to loads or load combinations not including wind or seismic loads) exceeds 15 psi (100 kPa) multiplied by appropriate adjustment factors, radial reinforcement shall be required. Design values for radial tension for radially-reinforced members shall be limited to 1/3 of the shear design value for non-prismatic members. Radial reinforcement shall be designed in accordance with the Timber Construction Manual (2). For wind and earthquake loading, the design value for radial tension shall be 1/3 of the shear design value for non-prismatic members.

Loading type	Softwood Species Other Than Southern Pine	Southern Pine
Wind or seismic	1/3 of F_{vx} for non-prismatic members	1/3 of F_{vx} for non-prismatic members
Other loading	15 psi (100 kPa) (a)	1/3 of F_{vx} for non-prismatic members

(a) If the calculated radial tension stress (due to loads or load combinations not including wind or seismic loads) exceeds 15 psi (100 kPa) multiplied by appropriate adjustment factors, radial reinforcement shall be required. Design values for radial tension for radially-reinforced members shall be limited to 1/3 of the shear design value for non-prismatic members. Radial reinforcement shall be designed in accordance with the Timber Construction Manual (2).

24.10 Torsion Design Values, F_{vt}

The torsion design value shall be taken as 2/3 of the shear design value, F_{vx} , for non-prismatic members.

24.11 Modulus of Rigidity

In lieu of specific data, the modulus of rigidity shall be taken as 1/16 of the long-span modulus of elasticity, as defined in the ASTM D3737 (9), or E_{true} for the lowest grade lamination used in the lay-up. If data are available, they shall be permitted to be used to determine the modulus of rigidity.

Note NOTE 5: The lowest grade lamination used in the lay-up can be found in Annex B. The E_{true} for the lowest grade lamination can be determined from Table A2 based on $E_{true} = E_{axial}$, as specified in Section 24.5.

24.12 Reference Design Value Tables

The design values provided in Table A1, Table A1-Expanded, and Table A2 are valid for beam and column applications. The design values in Table A1 and Table A1-Expanded are applicable to members with 4 or more laminations and are intended primarily for members stressed in bending about the x-x axis (Figure 24.1-1). Design values are included, however, for axial stresses and stresses from bending about the y-y axis (Figure 24.1-1). The values in Table A1 are for the industry recommended stress classes. Each stress class is representative of a group of combinations with similar design values. Design values for individual combinations are shown in Table A1-Expanded.

Table A2 contains design values for ~~timbers-members~~ with uniform grade ~~lay-uplayups~~. These combinations are intended primarily for ~~timbers-members~~ loaded axially or in bending about the y-y axis (Figure 24.1-1). Design values are included, however, for bending about the x-x axis (Figure 24.1-1).

The design values in Table A3 are applicable to stress classes and combinations that have been modified by secondary manufacturing or fabrication by removing material from the compression face to create a tapered beam. The design values in Table A3 shall replace the corresponding design values in Table A1 or Table A1-Expanded for all such tapered beams. For members manufactured with taper in the laminating plant with compression zone grade requirements maintained, the design values published in Table A1 shall apply.

35. LAY-UP/LAYUP REQUIREMENTS

35.1 Lumber Grades

Lumber grades shall be in accordance with Annex C of this standard and Section 4.3—Lumber for Laminating of ANSI A190.1-~~(3)~~.

35.2 Substitutions

Lumber of higher grades of the same species is permitted to be substituted in all ~~lay-uplayups~~ with some restrictions. Visually graded lumber shall not be permitted to be substituted for E-rated lumber. Substitutions of E-rated lumber grades for visual grades of lumber shall be approved by the laminator's accredited inspection agency prior to making the substitution. Full or partial length substitutions are permitted.

35.3 Determining Number of Laminations in Each Zone

The number of laminations to use in each zone in the ~~lay-uplayup~~ shall be calculated based on the percentages shown in Tables B1 and B2. Percent values shall be multiplied by the total depth of the member expressed in the number of laminations. The required number of laminations shall be determined starting with the outer zones and working inward. When the calculated number of laminations results in a fractional number, the fractional number of laminations shall be rounded upward to the next whole number. For the inner zones, the resulting excess of percentage resulting from rounding upward of the outer zone is permitted to be subtracted from the next inner zone requirements.

Example: The tension zone of a hypothetical 16 lamination beam requires 5% 302-24, 15% L1, and 10% L2.

The number of 302-24 laminations is determined by: $16 \times 0.05 = 0.8$ (rounded up to 1).

The combined number of 302-24 and L1 laminations is: $16 \times (0.05 + 0.15) = 3.2$ lams (round up to 4). Since there is already 1 lam of 302-24 from the calculation above, the required number of L1 lams is $4 - 1 = 3$ lams.

The combined number of 302-24, L1, and L2 lams is $16 \times (0.05 + 0.15 + 0.10) = 4.8$ lams (rounded up to 5).

Since there are already 1 lam of 302-24 and 3 lams of L1 from the calculation above, the required number of L2 lams is $5 - 4 = 1$ lam.

Where more than one thickness is used within a member and those lamination thicknesses vary by more than 3/16 inch (5 mm), the total thickness of each grade of lumber required in the inner and outer tension and compression zones shall be determined by using the thickest lamination in the member as the basic lamination thickness.

Example: When the thickest lamination used is 1-3/8 inches (35 mm) and 1.6 inches (41 mm) of L1 grade is required in a zone (based on multiplying the percentage required for that zone in the table by the depth of the member in inches), then a total thickness of at least 2-3/4 inches (70 mm) of L1 grade is required in that zone.

35.4 Wane

Certain combinations are permitted to contain wane. These combinations are for dry conditions of use only, except as allowed in ANSI A190.1 ~~(3)~~. These combinations allow wane up to 1/6 the width of the member on each side of the member. When this is the case, the basic shear design value shall be reduced by 1/3. When wane is restricted to just one side of the member, the basic design shear value shall be reduced by 1/6. When wane material is used in these combinations, members shall be for industrial or framing appearance grades and for prismatic members only.

Selectively placed wane is permitted for use in glued laminated timber combinations without a corresponding reduction in shear design values based on the following set of rules. Combinations meeting these requirements are for dry conditions of use only, except as allowed in ANSI A190.1 ~~(3)~~. When wane material is used in these combinations, members shall be for industrial or framing appearance grades and for prismatic members only.

1. Lumber with wane up to 1/6 of the finished member width and 1/2 of the lamination thickness shall be permitted on only one side of the member.
2. No wane shall be permitted within the central 40% of the depth of the cross section.
3. No wane shall be permitted in the outer laminations (top and bottom).
4. No wane shall be permitted in the 302 grade tension laminations.
5. No wane shall be permitted at the glue lines adjacent to the top or bottom laminations or at glue lines adjacent to 302 grade tension laminations.
6. Wane shall not be permitted at the interior edge joint of multi-piece laminations.
7. Combinations utilizing wane conforming to these rules shall be designated with a "W1" in the combination symbol (i.e., 24F-V1-W1). Appropriate stamps shall be obtained from the laminator's accredited inspection agency prior to production.

35.5 Tension Laminations

35.5.1 General

The flexural design values for most combinations listed in *Table A1* require the use of specially graded tension laminations in the outer 5% of beam depth on the tension side(s). These special grades are designated as "302 tension laminations" and commonly referred to as "special tension laminations."

35.5.2 Combinations without 302 Tension Laminations

Combinations requiring 302 tension laminations are permitted to be manufactured without the 302 tension lamination grade requirements provided the tabular design value for extreme fiber in bending about the x-x axis, F_{bx} , is multiplied by 0.75 for depths greater than 15 inches (380 mm) or by 0.85 for depths less than or equal to 15 inches (380 mm). When the 302 tension laminations specified in *Table B1* are omitted in visually graded ~~lay-~~
~~uplays~~ that normally require 302 tension laminations, they shall be replaced by dense laminations with a maximum slope of grain of 1:14 with knots and other strength-reducing characteristics meeting the requirements of L1 or No. 1, based on the normal lamination grading requirements used for the species.

35.5.3 Arches

302 tension laminations shall not be required for arches.

35.6 Tapered Members

Combination requirements, including 302 tension lamination requirements, shall apply for every cross-section along the entire length of tapered beams (Figure 35.6-1) unless the shop drawings or instructions from the designer indicate otherwise. Tudor arches (Figure 35.6-2) shall be laid up in accordance with *AITC/WCLIB 200* ~~(1)~~ or *APA Quality Assurance Policy for Structural Glued Laminated Timber* ~~(5)~~, unless specified otherwise.

Figure 35.6-1

TAPERED BEAMS

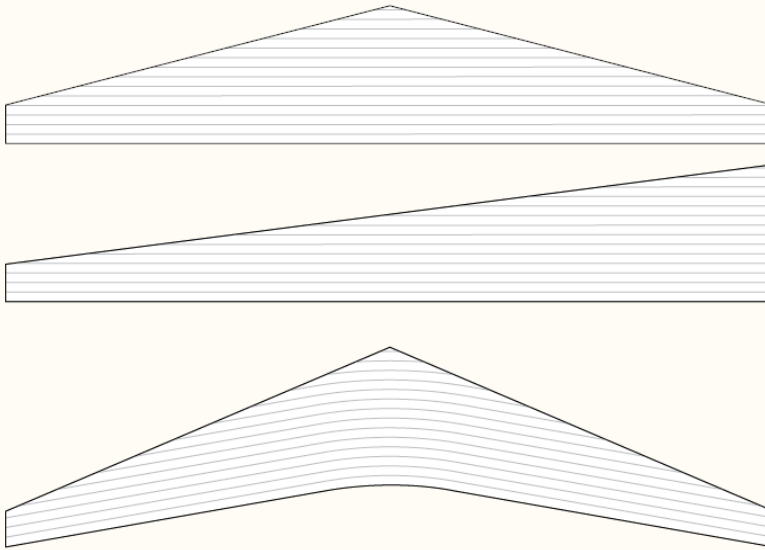
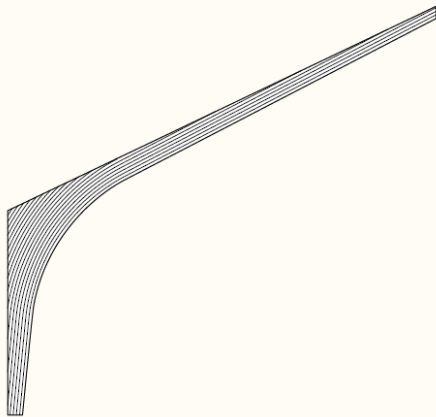

Figure 35.6-2

TUDOR ARCH



35.7 Fire-Resistive Construction

When bending members are specified to be one-hour fire-resistive, they shall be manufactured to the specified ~~lay-up~~layup as tabulated except that a core lamination shall be removed, the tension zone moved inward and the equivalent of one additional nominal 2-inch thickness outer tension lamination added.

When bending members are specified to be one-and-one-half-hour or two-hour fire-resistive, they shall be manufactured to the same lay-up as tabulated except that two core laminations shall be removed, the tension zone moved inward and the equivalent of two additional nominal 2-inch thickness outer tension laminations added.

For members designed for fire exposure on four sides, both the top and bottom of the lay-up shall be modified to meet these requirements. For lay-ups designed for fire exposure on three sides, only the bottom shall require modification.

Lay-ups modified to meet these requirements shall be marked with "1-HOUR FIRE RATING" if one additional tension lamination is used or "2-HOUR FIRE RATING" if two additional tension laminations are used. Additionally, balanced lay-ups designed and manufactured for three-sided fire exposure shall be marked with "TOP" on the appropriate face to ensure proper orientation in the structure.

35.8 Cross Sections with Bevel Cuts on Compression Face

Beams manufactured with a bevel cut (or cuts) on the compression face (Figure 35.8-1) shall be laid up so that the grade of laminations in the outer compression zone is maintained through the entire depth of the bevel cut. Where necessary, core laminations shall be removed and additional compression laminations shall be added to meet this requirement.

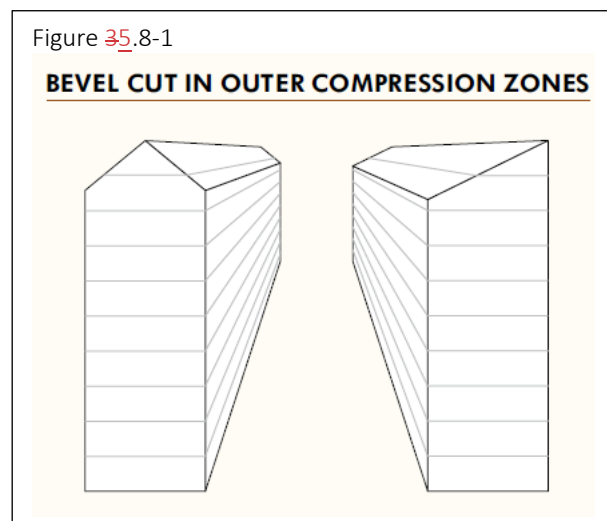

35.9 Non-Standard Depths

For beams with non-standard depths, (i.e., I-joist compatible depths, etc.), grade requirements of the combination shall be maintained throughout the depth of the lay-up.

For unbalanced lay-ups, any of three options shall be permitted to be used:

- 1) All laminations are permitted to be planed to a constant thickness.
- 2) One or more core laminations are permitted to be planed to a thinner dimension.
- 3) A core lamination is permitted to be removed with one extra compression lamination added with the excess material removed from the compression side after laminating.

For balanced lay-ups, either Option (1) or Option (2) shall be used.

46. ALTERNATE COMBINATIONS

46.1 General

The development and use of alternate combinations allows for more efficient and innovative use of the lumber resource. Combinations not listed in this Specification shall be permitted to be used, subject to the provisions of this Section.

Alternate ~~lay-up~~layups shall be approved by the laminator's accredited inspection agency prior to production. Alternate combinations shall be given a unique designation following industry protocols for assigning combination symbols.

46.2 Design Values

Design values for alternate ~~lay-up~~layups shall be established by analysis in accordance with ASTM D3737-~~(9)~~ or by full-scale testing in accordance with ASTM D7341-~~(13)~~ and analysis in accordance with ASTM D2915-~~(8)~~. All design values shall be approved by the laminator's accredited inspection agency before use.

46.2.1 Design Values by Analysis Only

For combinations developed by analysis only, the design values shall be established according to ASTM D3737-~~(9)~~. In addition, for horizontally laminated beams, the maximum outer fiber bending stress calculated according to transformed section analysis shall not exceed the nominal bending stress by more than 10% unless the end joints are qualified and maintained at a higher qualification stress level (QSL).

46.2.2 Design Values by Full-Scale Testing and Analysis

Design values shall be permitted to be established following the procedures of ASTM D7341-~~(13)~~ and ASTM D2915-~~(8)~~. Samples chosen for full-scale testing shall be representative of production. Full scale beam tests shall be conducted by an accredited testing lab or witnessed by a representative of an accredited inspection agency.

46.3 Quality Assurance

The production parameters and end joint QSL's from the initial qualification shall be the basis of the manufacturing facility's quality assurance requirements for alternate ~~lay-up~~layups with design values established by full-scale testing. Documentation of these requirements shall be maintained at the manufacturing facility and shall be available to the laminator's accredited inspection agency. Periodic evaluation shall be conducted as required by ASTM D7341-~~(13)~~ to ensure that test-based design values are maintained over time.

46.4 Documentation

Documentation of the design values and ~~lay-up~~layup requirements for alternate ~~lay-up~~layups shall be maintained by the accredited inspection agency and by the laminator. This documentation shall be available to the public upon request.

ANNEX A
DESIGN VALUE TABLES FOR STRUCTURAL GLUED LAMINATED SOFTWOOD TIMBER

(Secretariat Notes: Changes to Tables A1, A1-Expanded, and A2 are provided below. No changes to Table A3.)

TABLE A1

REFERENCE DESIGN VALUES FOR STRUCTURAL GLUED LAMINATED SOFTWOOD TIMBER

(Members stressed primarily in bending) [Tabulated design values are for normal load duration and dry service conditions.]

Stress Class	Loaded Perpendicular to Wide Faces of Laminations						Loaded Parallel to Wide Faces of Laminations													
	Extreme Fiber in Bending			Modulus of Elasticity			Modulus of Elasticity			Modulus of Elasticity										
	Bottom of Beam Stressed in Tension (Positive Bending)	Top of Beam Stressed in Tension (Negative Bending)	$F_{b,+}$ (psi)	$F_{b,-}$ (psi)	$F_{c,⊥}$ (psi)	$F_{v,⊥}$ (psi)	For Deflection Calculations	For Stability Calculations	Shear Parallel to Grain	Compression Perpendicular to Grain	Shear Parallel to Grain	Extreme Fiber in Bending	Compression Perpendicular to Grain	Shear Parallel to Grain	For Deflection Calculations	For Stability Calculations	Axially Loaded		Fasteners	
																	Tension Parallel to Grain	Compression Parallel to Grain		Specific Gravity for Fastener Design
$F_{b,+}$ (psi)	$F_{b,-}$ (psi)	$F_{c,⊥}$ (psi)	$F_{v,⊥}$ (psi)	E_{min} (10 ⁶ psi)	E_{app} (10 ⁶ psi)	E_{min} (10 ⁶ psi)	E_{app} (10 ⁶ psi)	$F_{c,∥}$ (psi)	$F_{v,∥}$ (psi)	$F_{c,∥}$ (psi)	$F_{v,∥}$ (psi)	E_{min} (10 ⁶ psi)	E_{app} (10 ⁶ psi)	$F_{t,∥}$ (psi)	$F_{c,∥}$ (psi)	G				
16F-1.5E	1600	925	315	195	1.4	1.3	0.69	1.2	1.1	170	600	315	170	1.2	1.1	0.58	1.2	675	925	0.41
20F-1.5E	2000	1100	425	195 ^(b)	1.6	1.5	0.79	1.3	1.2	170	800	315	170	1.3	1.2	0.63	1.2	725	925	0.41
24F-1.7E	2400	1450	500	210 ^(b)	1.8	1.7	0.90	1.4	1.3	185	1050	315	185	1.4	1.3	0.69	1.3	775	1000	0.42
24F-1.8E	2400	1450	450 ^(d)	265 ^(d)	1.9	1.8	0.95	1.4	1.6	230 ^(d)	1450	560	230 ^(d)	1.7	1.6	0.85	1.6	1100	1600	0.50 ^(g)
26F-1.9B ^(h)	2600	1950	650	265 ^(h)	2.0	1.9	1.00	1.6	1.6	230 ^(h)	1600	560	230 ^(h)	1.7	1.6	0.85	1.6	1150	1600	0.50 ^(g)
26F-2.1E 5P ⁽ⁱ⁾	2600	2300	805	300	2.2 ⁽ⁱ⁾	2.1 ⁽ⁱ⁾	1.09 ⁽ⁱ⁾	1.7	1.7	260	1600	650	260	1.8	1.7	0.90	1.7	1200	1700	0.55
30F-2.1E 3P ⁽ⁱ⁾	3000	2400	805	300	2.2 ⁽ⁱ⁾	2.1 ⁽ⁱ⁾	1.09 ⁽ⁱ⁾	1.7	1.7	260	1750	650	260	1.8	1.7	0.90	1.7	1250	1750	0.55

Footnotes to Table A1

- (a) For balanced layers, $F_{b,+}$ shall be equal to $F_{b,-}$ for the stress class. Designers shall specify when balanced layup is required.
 - (b) Negative bending stress, $F_{b,-}$, is permitted to be increased to 1850 psi for southern pine for specific combinations. Designers shall specify when these increased stresses are required.
 - (c) For structural glued laminated timber of southern pine, the basic shear design values, $F_{c,⊥}$ and $F_{v,⊥}$, are permitted to be increased to 300 psi and 260 psi, respectively.
 - (d) The design values for shear, $F_{c,⊥}$ and $F_{v,⊥}$, shall be decreased by multiplying by a factor of 0.72 for non-prismatic members, notched members, and/or all members subject to impact or cyclic loading. The reduced design value shall be used for design of members at connections that transfer shear by mechanical fasteners. The reduced design value shall also be used for determination of design values for radial tension and tension.
 - (e) Design values are for timbers with laminations made from a single piece of lumber across the width or multiple pieces that have been edge bonded. For timbers manufactured from multiple piece laminations (across width) that are not edge bonded, values shall be multiplied by 0.4 for members with 5, 7, or 9 laminations or by 0.5 for all other members. This reduction shall be cumulative with the adjustment in footnote (d).
 - (f) Certain southern pine combinations may contain lumber with wane. If lumber with wane is used, the design value for shear parallel to grain, $F_{v,∥}$, shall be multiplied by 0.67 if wane is allowed on both sides. If wane is limited to one side, $F_{v,∥}$ shall be multiplied by 0.83. This reduction shall be cumulative with the adjustment in footnote (d).
 - (g) 26F, 28F, and 30F beams are not produced by all manufacturers; therefore, availability may be limited. Contact supplier or manufacturer for details.
 - (h) 30F combinations are restricted to a maximum 6 in. nominal width unless the manufacturer has qualified for wider widths based on full-scale tests subject to approval by an accredited inspection agency.
 - (i) For 28F and 30F members with more than 15 laminations, E_{min} = 2.1 x 10⁶ psi and E_{app} = 2.0 x 10⁶ psi and E_{min} = 2.1 x 10⁶ psi and E_{app} = 2.0 x 10⁶ psi and E_{min} = 2.1 x 10⁶ psi and E_{app} = 2.0 x 10⁶ psi.
- Stress classes represent groups of similar glued laminated timber combinations. Values for individual combinations are included in Table A1-E-Expanded. Design values are for members with 4 or more laminations. For 2 and 3 lamination members, see Table A2. Some stress classes are not available in all species. Contact manufacturer for availability.

TABLE A1-EXPANDED

REFERENCE DESIGN VALUES FOR STRUCTURAL GLUED LAMINATED SOFTWOOD TIMBER COMBINATIONS^(a)

(Members stressed primarily in bending). [Tabulated design values are for normal load duration and dry service conditions.]

Combination Symbol	Species Outer/Core	Loaded Perpendicular to Wide Faces of Laminations						Bending About X-X Axis (Loaded Parallel to Wide Faces of Laminations)						As Laminated		Fasteners Specific Gravity for Fastener Design		
		Extreme Fiber in Bending			Compression Perpendicular to Grain			Extreme Fiber in Bending	Modulus of Elasticity	F _w ^(M) (psi)	F _w ^(B) (psi)	F _v ^(M) (psi)	F _v ^(B) (psi)	Tension Parallel to Grain	Compression Parallel to Grain		F _c (psi)	G
		F _w ^(T) (psi)	F _w ^(C) (psi)	F _w ^(S) (psi)	F _{ax} (psi)	F _{ax} (psi)	F _{ax} (psi)											
16F-1.3E		1600	925	315	315	195	1.4	1.3	0.69	800	315	170	1.2	1.1	0.58	675	925	0.41
16F-V3	DF/DF	1600	1250	560	560	265	1.6	1.5	0.79	1430	560	230	1.6	1.5	0.79	975	1000	0.50
16F-V6	DF/DF	1600	1600	560	560	265	1.7	1.6	0.85	1430	560	230	1.6	1.5	0.79	1000	1600	0.50
16F-E2	HF/DF	1600	1050	375	375	215	1.5	1.4	0.74	1200	375	190	1.4	1.3	0.69	825	1150	0.43
16F-E3	DF/DF	1600	1200	560	560	265	1.7	1.6	0.85	1400	560	230	1.6	1.5	0.79	975	1600	0.50
16F-E6	DF/DF	1600	1600	560	560	265	1.7	1.6	0.85	1500	560	230	1.6	1.5	0.79	1000	1600	0.50
16F-E7	HF/DF	1600	1600	375	375	215	1.5	1.4	0.74	1350	375	190	1.4	1.3	0.74	875	1250	0.43
16F-V2	SP/SP	1600	1400	740	650	300	1.6	1.5	0.79	1430	650	260	1.5	1.4	0.74	1000	1300	0.55
16F-V3	SP/SP	1600	1400	740	740	300	1.5	1.4	0.74	1430	740	260	1.5	1.4	0.74	975	1400	0.55
16F-V5	SP/SP	1600	1600	650	650	300	1.7	1.6	0.85	1600	650	260	1.6	1.5	0.79	1000	1500	0.55
16F-E1	SP/SP	1600	1250	650	650	300	1.7	1.6	0.85	1600	650	260	1.7	1.6	0.85	1050	1500	0.55
16F-E3	SP/SP	1600	1600	650	650	300	1.8	1.7	0.90	1650	650	260	1.7	1.6	0.85	1100	1500	0.55
20F-1.5E		2000	1100	425	425	195	1.6	1.5	0.79	800	315	170	1.3	1.2	0.63	725	925	0.41
20F-V3	DF/DF	2000	1450	650	560	265	1.7	1.6	0.85	1430	560	230	1.6	1.5	0.79	1000	1650	0.50
20F-V7	DF/DF	2000	2000	650	650	265	1.7	1.6	0.85	1430	650	230	1.7	1.6	0.85	1050	1600	0.50
20F-V12	AC/JAC	2000	1400	560	560	265	1.6	1.5	0.79	1230	470	230	1.5	1.4	0.74	925	1000	0.46
20F-V13	AC/JAC	2000	2000	560	560	265	1.6	1.5	0.79	1230	470	230	1.5	1.4	0.74	950	1050	0.46
20F-V14	POC/POC	2000	1450	560	560	265	1.6	1.5	0.79	1300	470	230	1.5	1.4	0.74	900	1600	0.46
20F-V15	POC/POC	2000	2000	560	560	265	1.6	1.5	0.79	1300	470	230	1.5	1.4	0.74	925	1600	0.46
20F-E2	HF/DF	2000	1400	500	500	215	1.7	1.6	0.85	1200	375	190	1.5	1.4	0.74	925	1350	0.43
20F-E3	DF/DF	2000	1700	560	560	265	1.8	1.7	0.90	1400	560	230	1.7	1.6	0.85	1050	1600	0.50
20F-E6	DF/DF	2000	2000	560	560	265	1.8	1.7	0.90	1500	560	230	1.7	1.6	0.85	1150	1600	0.50
20F-E7	HF/DF	2000	2000	500	500	215	1.8	1.6	0.85	1430	375	190	1.5	1.4	0.74	1050	1460	0.43
20F-E8	DF/DF	2000	2000	450	450	200	1.6	1.5	0.79	1000	315	175	1.5	1.4	0.74	825	1100	0.41
24F-E/SPE1	SPE/SPE	2400	2400	560	560	215	1.7	1.6	0.85	1130	470	190	1.7	1.6	0.85	1150	2000	0.42
24F-E/SPE3	SPE/SPE	2400	1550	560	560	215	1.7	1.6	0.85	1200	470	195	1.6	1.5	0.79	900	1750	0.42
20F-V2	SP/SP	2000	1550	740	650	300	1.6	1.5	0.79	1430	650	260	1.5	1.4	0.74	1000	1600	0.55
20F-V3	SP/SP	2000	1450	650	650	300	1.6	1.5	0.79	1600	650	260	1.6	1.5	0.74	1000	1400	0.55
20F-V5	SP/SP	2000	2000	740	740	300	1.7	1.6	0.85	1430	650	260	1.5	1.4	0.74	1050	1000	0.55
20F-E1	SP/SP	2000	1500	650	650	300	1.8	1.7	0.90	1400	650	260	1.7	1.6	0.85	1050	1350	0.55
20F-E3	SP/SP	2000	2000	650	650	300	1.8	1.7	0.90	1700	650	260	1.7	1.6	0.85	1150	1600	0.55
24F-1.7E		2400	1450	500	500	210	1.8	1.7	0.90	1050	315	185	1.4	1.3	0.69	775	1000	0.42
24F-V5	DF/DF	2400	1600	650	650	215	1.8	1.7	0.90	1330	375	200	1.6	1.5	0.79	1100	1450	0.43
24F-V10	DF/DF	2400	2400	650	650	215	1.9	1.8	0.95	1450	375	200	1.6	1.5	0.79	1150	1500	0.50
24F-E11	HF/DF	2400	2400	500	500	215	1.9	1.8	0.95	1530	375	190	1.6	1.5	0.79	1150	1500	0.43
24F-E15	HF/DF	2400	1600	500	500	215	1.9	1.8	0.95	1200	375	190	1.6	1.5	0.79	975	1300	0.43
24F-V1	SP/SP	2400	1750	740	650	300	1.8	1.7	0.90	1430	650	260	1.6	1.5	0.79	1100	1300	0.55
24F-V4H1	SP/SP	2400	1650	740	650	210	1.8	1.7	0.90	1330	470	230	1.6	1.5	0.79	975	1350	0.43
24F-V5	SP/SP	2400	2400	740	740	300	1.8	1.7	0.90	1700	650	260	1.7	1.6	0.85	1150	1600	0.55

TABLE A1-EXPANDED (Continued)

REFERENCE DESIGN VALUES FOR STRUCTURAL GLUED LAMINATED SOFTWOOD TIMBER COMBINATIONS^(a)
 (Members stressed primarily in bending) (Tabulated design values are for normal load duration and dry service conditions.)

Combination Symbol	Species Outer/Core	[Loaded Perpendicular to Wide Faces of Laminations]				[Loaded Parallel to Wide Faces of Laminations]				Axially Loaded		Fasteners Specific Gravity for Fastener Design		
		Extreme Fiber in Bending		Compression Perpendicular to Grain		Extreme Fiber in Bending		Compression Perpendicular to Grain		Tension Parallel to Grain	Compression Parallel to Grain			
		Bottom of beam Stressed in Tension (Positive Bending)	Top of beam Stressed in Tension (Negative Bending)	F_{ax} (psi)	F_{ax} (psi)	F_{bx} (psi)	F_{bx} (psi)	F_{cy} (psi)	F_{cy} (psi)					
		F_{bx}^+ (psi)	F_{bx}^- (psi)	E_{ext}^+ (10^6 psi)	E_{ext}^- (10^6 psi)	E_{xyp} (10^6 psi)	E_{xyp} (10^6 psi)	E_{xyp} (10^6 psi)	E_{xyp} (10^6 psi)	E_{xyp} (10^6 psi)	E_{xyp} (10^6 psi)	F_t (psi)	F_c (psi)	G
24F-1.8E		2400	850-460	1.9	1.8	0.95	0.95	1.7	1.6	0.85	1100	1600	0.50	
24F-W	DF/DF	2400	1850	1.9	1.8	0.95	0.95	560	560	0.85	1100	1650	0.50	
24F-V8	DF/DF	2400	2400	1.9	1.8	0.95	0.95	560	560	0.85	1100	1650	0.50	
24F-E4	DF/DF	2400	1460	1.9	1.8	0.95	0.95	560	560	0.85	1100	1650	0.50	
24F-E13	DF/DF	2400	2400	1.9	1.8	0.95	0.95	560	560	0.85	1100	1650	0.50	
24F-E18	DF/DF	2400	2400	1.9	1.8	0.95	0.95	560	560	0.85	1100	1650	0.50	
24F-V3	SP/SP	2400	2000	1.9	1.8	0.95	0.95	650	650	0.85	1150	1650	0.55	
24F-V8	SP/SP	2400	2400	1.9	1.8	0.95	0.95	650	650	0.85	1150	1650	0.55	
24F-E1	SP/SP	2400	805	1.9	1.8	0.95	0.95	650	650	0.85	1150	1650	0.55	
24F-E4	SP/SP	2400	805	1.9	1.8	0.95	0.95	650	650	0.85	1150	1650	0.55	
24F-E13	SP/SP	2400	805	1.9	1.8	0.95	0.95	650	650	0.85	1150	1650	0.55	
24F-E18	SP/SP	2400	805	1.9	1.8	0.95	0.95	650	650	0.85	1150	1650	0.55	
24F-V1	DF/DF	2600	1950	2.0	1.9	1.00	1.00	560	560	0.85	1150	1600	0.50	
24F-V2	DF/DF	2600	2600	2.1	2.0	1.06	1.06	560	560	0.85	1150	1600	0.50	
24F-V1	SP/SP	2600	2000	1.9	1.8	0.95	0.95	740	740	0.85	1300	1850	0.55	
24F-V2	SP/SP	2600	2100	1.9	1.8	0.95	0.95	740	740	0.85	1300	1850	0.55	
24F-V3	SP/SP	2600	2100	2.0	1.9	1.00	1.00	740	740	0.85	1300	1850	0.55	
24F-W	SP/SP	2600	2600	2.0	1.9	1.00	1.00	740	740	0.85	1300	1850	0.55	
24F-V	SP/SP	2600	2600	2.0	1.9	1.00	1.00	740	740	0.85	1300	1850	0.55	
28F-2.1E 5PP		2800	2300	2.0	1.9	1.11	1.11	650	650	0.90	1250	1750	0.55	
28F-E1	SP/SP	2800	805	2.0	1.9	1.11	1.11	650	650	0.90	1250	1750	0.55	
28F-E2	SP/SP	2800	805	2.0	1.9	1.11	1.11	650	650	0.90	1250	1750	0.55	
30F-2.1E 5PP		3000	2400	2.0	1.9	1.16	1.16	650	650	0.90	1250	1750	0.55	
30F-E1	SP/SP	3000	805	2.0	1.9	1.16	1.16	650	650	0.90	1250	1750	0.55	
30F-E2	SP/SP	3000	805	2.0	1.9	1.16	1.16	650	650	0.90	1250	1750	0.55	

Footnotes to Table A1-Expanded:

- (a) The combination in this table are applicable to members consisting of 4 or more laminations and are intended primarily for members stressed in bending due to loads applied perpendicular to the wide faces of the laminations. However, design values are tabulated for loading both perpendicular and parallel to the wide faces of the laminations. For combinations and design values applicable to members loaded primarily axially or parallel to the wide face of the laminations, see Table A2. For members of 2 or 3 laminations, see Table A2.
- (b) The design values for shear, F_w and F_v shall be decreased by multiplying by a factor of 0.72 for non-prismatic members, notched members, and for all members subject to impact or cyclic loading. The reduced design value shall be used for design of members of connections that transfer shear by mechanical fasteners. The reduced design value shall also be used for determination of design values for radial tension and torsion.
- (c) Design values are for timbers with laminations made from a single piece of lumber across the width or multiple pieces that have been edge banded. For lumber manufactured from multiple piece laminations (across width) that are not edge-banded, value shall be multiplied by 0.4 for members with 5, 7, or 9 laminations or by 0.5 for all other members. This reduction shall be cumulative with the adjustment in footnote (b).
- (d) This combination may contain lumber with wane. If lumber with wane is used, the design value for shear parallel to grain, F_{vx} , shall be multiplied by 0.67 if wane is allowed on both sides. If wane is limited to one side, F_{vx} shall be multiplied by 0.83. This reduction shall be cumulative with the adjustment in footnote (b).
- (e) 26F, 28F, and 30F beams are not produced by all manufacturers, therefore, availability may be limited. Contact supplier or manufacturer for details.
- (f) 30F combinations are limited to a maximum 6 in. nominal width unless the manufacturer has qualified for wider widths based on full-scale tests subject to approval by an accredited inspection agency.
- (g) For 28F and 30F members with more than 15 laminations, $E_{xyp}^+ = 2.1 \times 10^6$ psi, $E_{xyp}^- = 2.0 \times 10^6$ psi, and $E_{xyp} = 1.06 \times 10^6$ psi.

TABLE A2 – REFERENCE DESIGN VALUES FOR STRUCTURAL GLUED LAMINATED SOFTWOOD TIMBER

(Members stressed primarily in axial tension or compression)

(Tabulated design values are for normal load duration and dry service conditions.)

Combination Symbol	Species	Grade	All Loading				Axially Loaded			Bending about Y-Y Axis Loaded Parallel to Wide Faces of Laminations			Bending About X-X Axis Loaded Perpendicular to Wide Faces of Laminations		
			Modulus of Elasticity			Compression Perpendicular to Grain F _{c⊥} (psi)	Tension Parallel to Grain F _t (psi)	Compression Parallel to Grain F _c (psi)	Bending			Shear Parallel to Grain ^{(a)(b)(c)} F _{vy} (psi)	Bending 2 Laminations to 15 in. Deep ^(d) F _{bx}	Shear Parallel to Grain ^(e) F _{vx} (psi)	
			$E_{x,true}$ $E_{y,true}$ OR E _{axial} (10 ⁸ psi)	$E_{x,app}$ OR $E_{y,app}$ 0-95 E _{axial} (10 ⁸ psi)	$E_{x,min}$, $E_{y,min}$ OR E _{axial min} (10 ⁸ psi)				4 or More Laminations F _t (psi)	2 or 3 Laminations F _c (psi)	4 or More Laminations F _{by} (psi)				3 Laminations F _{by} (psi)
Visually Graded Western Species															
1	DF	L3	1.6	1.5	0.79	560	950	1550	1250	1450	1250	1000	230	1250	265
2	DF	L2	1.7	1.6	0.85	560	1250	1950	1600	1800	1600	1300	230	1700	265
3	DF	L2D	2.0	1.9	1.00	650	1450	2300	1900	2100	1850	1550	230	2000	265
4	DF	L1CL	2.0	1.9	1.00	590	1400	2100	1950	2200	2000	1650	230	2100	265
5	DF	L1	2.1	2.0	1.06	650	1650	2400	2100	2400	2100	1800	230	2200	265
14	HF	L3	1.4	1.3	0.69	375	800	1100	1050	1200	1050	850	190	1100	215
15	HF	L2	1.5	1.4	0.74	375	1050	1350	1350	1500	1350	1100	190	1450	215
16	HF	L1	1.7	1.6	0.85	375	1200	1500	1500	1750	1550	1300	190	1600	215
17	HF	L1D	1.8	1.7	0.90	500	1400	1750	1750	2000	1850	1550	190	1900	215
22 ^(e)	SW	L3	1.1	1.0	0.53	315	525	850	725	800	700	575	170	725	195
69	AC	L3	1.3	1.2	0.63	470	725	1150	1100	1100	975	775	230	1000	265
70	AC	L2	1.4	1.3	0.69	470	975	1450	1450	1400	1250	1000	230	1350	265
71	AC	L1D	1.7	1.6	0.85	560	1250	1900	1900	1850	1650	1400	230	1750	265
72	AC	L1S	1.7	1.6	0.85	560	1250	1900	1900	1850	1650	1400	230	1900	265
73	POC	L3	1.4	1.3	0.69	470	775	1500	1200	1200	1050	825	230	1050	265
74	POC	L2	1.5	1.4	0.74	470	1050	1900	1550	1450	1300	1100	230	1400	265
75	POC	L1D	1.8	1.7	0.90	560	1350	2300	2050	1950	1750	1500	230	1850	265
Visually Graded Southern Pine															
47	SP	N2M12	1.5	1.4	0.74	650	1200	1900	1150	1750	1550	1300	260	1400	300
47 1:10	SP	N2M10	1.5	1.4	0.74	650	1150	1700	1150	1750	1550	1300	260	1400	300
47 1:8	SP	N2M	1.5	1.4	0.74	650	1000	1500	1150	1600	1550	1300	260	1400	300
48	SP	N2D12	1.8	1.7	0.90	740	1400	2200	1350	2000	1800	1500	260	1600	300
48 1:10	SP	N2D10	1.8	1.7	0.90	740	1350	2000	1350	2000	1800	1500	260	1600	300
48 1:8	SP	N2D	1.8	1.7	0.90	740	1150	1750	1350	1850	1800	1500	260	1600	300
49	SP	N1M16	1.8	1.7	0.90	650	1350	2100	1450	1950	1750	1500	260	1800	300
49 1:14	SP	N1M14	1.8	1.7	0.90	650	1350	2000	1450	1950	1750	1500	260	1800	300
49 1:12	SP	N1M12	1.8	1.7	0.90	650	1300	1900	1450	1950	1750	1500	260	1800	300
49 1:10	SP	N1M	1.8	1.7	0.90	650	1150	1700	1450	1850	1750	1500	260	1800	300
50	SP	N1D14	2.0	1.9	1.00	740	1550	2300	1700	2300	2100	1750	260	2100	300
50 1:12	SP	N1D12	2.0	1.9	1.00	740	1500	2200	1700	2300	2100	1750	260	2100	300
50 1:10	SP	N1D	2.0	1.9	1.00	740	1350	2000	1700	2100	2100	1750	260	2100	300

Footnotes to Table A2

- (a) For members with 2 or 3 laminations, the shear design value for transverse loads parallel to the wide faces of the laminations, F_{vy}, shall be reduced by multiplying by a factor of 0.84 or 0.95, respectively.
- (b) The shear design value for transverse loads applied parallel to the wide faces of the laminations, F_{vy}, shall be multiplied by 0.4 for members with 5, 7, or 9 laminations manufactured from multiple piece laminations (across width) that are not edge bonded. The shear design value, F_{vy}, shall be multiplied by 0.5 for all other members manufactured from multiple piece laminations with unbonded edge joints. This reduction shall be cumulative with the adjustment in footnote (1).
- (c) The design values for shear, F_{vx} and F_{vy}, shall be decreased by multiplying by a factor of 0.72 for non-prismatic members, notched members, and for all members subject to impact or cyclic loading. The reduced design value shall be used for design of members at connections that transfer shear by mechanical fasteners. The reduced design value shall also be used for determination of design values for radial tension and torsion.
- (d) The tabulated F_{bx} values are for members without special tension lams up to 15 inches in depth. If the member depth is greater than 15 inches without special tension lams, the tabulated F_{bx} values must be multiplied by a factor of 0.88. If special tension lams are used, the tabulated F_{bx} values are permitted to be increased by a factor of 1.18 regardless of the member depth provided that the increased F_{bx} value does not exceed 2,400 psi.
- (e) When Western Cedars, Western Cedars (North), Western Woods, and Redwood (open grain) are used in combinations for Softwood Species (SW), the design value for modulus of elasticity shall be reduced by 100,000 psi. When Coast Sitka Spruce, Coast Species, Western White Pine, and Eastern White Pine are used in combinations for Softwood Species (SW) tabulated design values for shear parallel to grain, F_{vx} and F_{vy}, shall be reduced by 10 psi, before applying any other adjustments.

ANNEX B

LAY-UP LAYUP REQUIREMENTS FOR STRUCTURAL GLUED LAMINATED SOFTWOOD TIMBER

(Secretariat Notes: Changes to Table B1 are provided below. No changes to Table B2.)

20F-V7 DF (Balanced)	4-10 Lams			11 or More Lams			<div style="border: 1px solid black; background-color: #4a7ebb; color: white; padding: 10px; display: inline-block;"> Change to 4-7 Lams </div>					
	5%	302-20 DF	—	5%	302-20 DF	—						
	5%	L2D DF	—	5%	L2 DF	—						
	—	L3 DF	—	—	L3 DF	—						
	—	—	—	5%	L2 DF	—						
5%	302-20 DF	—	5%	302-20 DF	—							
20F-V7 DF (Alternate)	4-10 Lams			8-10 Lams								
	10%	L1 DF	—	15%	L1 DF	—						
	—	—	—	—	—	—						
	—	L3 DF	—	—	L3 DF	—						
	—	—	—	—	—	—						
10%	L1 DF	—	15%	L1 DF	—							
20F-V12 AC (Unbalanced)	4-7 Lams			8-10 Lams			11-18 Lams			19 or More Lams		
	10%	L1D AC	—	10%	L1D AC	—	10%	L1D AC	—	10%	L1D AC	—
	15%	L2 AC	—	15%	L2 AC	—	15%	L2 AC	—	15%	L2 AC	—
	—	L3 AC	—	—	L3 AC	—	—	L3 AC	—	—	L3 AC	—
	10%	L2 AC	—	10%	L2 AC	—	10%	L2 AC	—	10%	L2 AC	—
	25%	L1D AC	—	30%	L1D AC	—	10%	L1S AC	—	10%	L1S AC	—
	5%	302-20 AC	1:14	5%	302-20 AC	1:14	5%	302-24 AC	—	5%	302-26 AC	—
20F-V13 AC (Balanced)	4-7 Lams			8-10 Lams			11 or More Lams					
	5%	302-20 AC	1:16	5%	302-22 AC	—	5%	302-24 AC	—			
	10%	L1S AC	—	10%	L1S AC	—	5%	L1S AC	—			
	10%	L1D AC	—	10%	L1D AC	—	10%	L1D AC	—			
	—	L3 AC	—	—	L3 AC	—	—	L3 AC	—			
	10%	L1D AC	—	10%	L1D AC	—	10%	L1D AC	—			
	10%	L1S AC	—	10%	L1S AC	—	5%	L1S AC	—			
	5%	302-20 AC	1:16	5%	302-22 AC	—	5%	302-24 AC	—			

Add the following note to the end of Table B1:

TABLE B1

LAYUP REQUIREMENTS FOR STRUCTURAL GLUED LAMINATED SOFTWOOD TIMBER COMBINATIONS^(a)

(a) The layout for each combination is tabulated with the required percentage of the beam depth for each laminating lumber grade from top to bottom of a glulam beam (see 5.3). For visually-graded layouts, a specific slope of grain limitation for the laminating lumber grade is also specified when the requirement is more restrictive than the standard laminating lumber grade (see Annex C). For E-rated layouts, an E-rated laminating lumber requirement is also specified, when appropriate, in addition to the standard tension lamination requirement.

ANNEX C
LAMINATING LUMBER GRADING RULES FOR STRUCTURAL GLUED LAMINATED TIMBERS

C1. INTRODUCTION

Lumber shall be either visually graded or mechanically graded as required for the laminating combinations. Structural laminating lumber shall be graded on the basis of the dressed size of the lumber. The knot sizes for structural laminating grades of western species are based on a fraction of the dressed width of the piece of lumber. This is in contrast to The-the knot sizes for structural joist and plank grades and structural light framing grades of all species, which are tabulated on the basis of the nominal width. When lumber is graded before being ripped or resawn, it shall be graded on the basis of the ripped or resawn size. Otherwise it shall be graded after being ripped or resawn. Where the finished width of the laminated timber is less than 85% of the dressed width of the lumber used for the laminations, the lumber shall be graded on the basis of the next smaller nominal width.

C2. DEFINITIONS/MEASUREMENT OF CHARACTERISTICS

C2.1 Bow

A deviation flatwise from a straight line drawn from end to end of a piece.

C2.2 Checks

A separation of the wood normally occurring across or through the rings of annual growth and usually as a result of seasoning.

C2.3 Compression Wood

Abnormal wood formed on the underside of leaning and crooked coniferous trees. It is characterized, aside from its distinguishing color, by being hard and brittle.

C2.4 Crook

A deviation edgewise from a straight line drawn from end to end of a piece.

C2.5 Cup

A deviation in the face of a piece from a straight line drawn from edge to edge of a piece.

C2.6 Decay

A disintegration of the wood substance due to action of wood-destroying fungi, and is also known as dote or rot.

C2.7 Edge Knot

A knot located at the edge of the face in a piece of lumber. A wide face knot overlapping part of the edge shall be considered an edge knot if it occupies more than 1/2 the thickness.

C2.8 Growth Rate

A characteristic used to estimate specific gravity from the number of growth rings per inch (25 mm) along with the amount of summerwood.

C2.9 Honeycomb

A form of decay similar to white speck but the pockets are larger.

C2.10 Knots

A portion of a branch or limb that has become incorporated in a piece of lumber. Knots are permitted to be sound, unsound, or not firmly fixed. A knot shall be measured by the area of the cross section it occupies. For all lumber, knots shall be limited in size and spaced as described for specific grades herein.

C2.11 Knotholes

The hole left when a "loose" knot falls or is forced from the lumber.

C2.12 Moisture Content

The weight of the water in wood expressed in percentage of the weight of the oven-dry wood.

C2.13 Raised Grain

A condition of the surface of dressed lumber in which the hard latewood is raised above the surface of the softer earlywood, but not torn loose from it.

C2.14 Shakes

A lengthwise separation of the wood which occurs between or through the rings of annual growth.

C2.15 Slope of Grain

The deviation of the line of fibers from a straight line parallel to the sides of the piece.

C2.16 Splits

A separation of the wood through the piece to the opposite surface or to an adjoining surface due to the tearing apart of the wood cells.

C2.17 Springwood or Earlywood

The less dense, larger-celled part of the growth layer formed first during the annual growth cycle.

C2.18 Summerwood or Latewood

The denser, smaller-celled, later-formed part of a growth ring.

C2.19 Torn Grain

A manufacturing imperfection in the surface of a piece where wood has been torn or broken out by surfacing.

C2.20 Twist

A deviation flatwise, or a combination of flatwise and edgewise, in the form of a curl or spiral.

C2.21 Wane

Bark or lack of wood from any cause except eased edges, on the edge or corner of a piece of lumber.

C2.22 Warp

Any deviation from a true or plane surface, including bow, crook, cup, **twist** or any combination thereof.

C2.23 White Speck

A form of decay identified by small white or brown pits or spots in wood caused by fungi. It develops in the living tree and does not develop further in wood in service.

2.2 Knots

A portion of a branch or limb that has become incorporated in a piece of lumber. Knots are permitted to be sound, unsound, or not firmly fixed. A knot shall be measured by the area of the cross-section it occupies. For all lumber, knots shall be limited in size and spaced as described for specific grades herein.

2.3 Edge Knot

A knot located at the edge of the face in a piece of lumber. A wide face knot overlapping part of the edge shall be considered an edge knot if it occupies more than 1/2 the thickness.

2.4 Knotholes

The hole left when a "loose" knot falls or is forced from the lumber.

2.5 Slope of Grain

The deviation of the line of fibers from a straight line parallel to the sides of the piece.

~~2.6 Splits~~

~~A separation of the wood through the piece to the opposite surface or to an adjoining surface due to the tearing apart of the wood cells.~~

~~2.7 Shakes~~

~~A lengthwise separation of the wood which occurs between or through the rings of annual growth.~~

~~2.8 Checks~~

~~A separation of the wood normally occurring across or through the rings of annual growth and usually as a result of seasoning.~~

2.9 Warp

Any deviation from a true or plane surface, including bow, crook and cup or any combination thereof.

2.9.1 Bow

A deviation flatwise from a straight line drawn from end to end of a piece.

2.9.2 Crook

A deviation edgewise from a straight line drawn from end to end of a piece.

2.9.3 Cup

A deviation in the face of a piece from a straight line drawn from edge to edge of a piece.

2.10 Torn Grain

A manufacturing imperfection in the surface of a piece where wood has been torn or broken out by surfacing.

2.11 Raised Grain

A condition of the surface of dressed lumber in which the hard latewood is raised above the surface of the softer earlywood, but not torn loose from it.

2.12 Wane

Bark or lack of wood from any cause except eased edges, on the edge or corner of a piece of lumber.

2.13 Decay

A disintegration of the wood substance due to action of wood-destroying fungi, and is also known as dote or rot.

2.13.1 White Speck

A form of decay identified by small white or brown pits or spots in wood caused by fungi. It develops in the living tree and does not develop further in wood in service.

2.13.2 Honeycomb

A form of decay similar to white speck but the pockets are larger.

2.14 Compression Wood

Abnormal wood formed on the underside of leaning and crooked coniferous trees. It is characterized, aside from its distinguishing color, by being hard and brittle. It is identified by its relatively wide, usually eccentric annual rings, relatively large amount of latewood (sometimes more than 50% of the width of the annual rings in which it occurs), and its lack of demarcation between earlywood and latewood in the same annual rings.

2.15 Springwood or Earlywood

The less dense, larger-celled part of the growth layer formed first during the annual growth cycle.

2.16 Summerwood or Latewood

The denser, smaller-celled, later formed part of a growth ring.

2.17 Growth Rate

A characteristic used to estimate specific gravity from the number of growth rings per inch along with the amount of summerwood.

C3. GENERAL REQUIREMENTS

C3.1 Moisture Content

Moisture content shall not exceed 16%. Moisture content determinations shall be based on ASTM D4442, ~~or~~ D4444, or D7438. In-line moisture meters used for lumber segregation shall be calibrated using one of these standards. The range of average moisture contents of pieces of lumber to be assembled into a single timber shall not exceed 5 percentage points if the average moisture content of any piece exceeds 12%. The moisture content of a piece of lumber shall be the average moisture content throughout the cross section and along the length of the piece. Exception: when it is known that the in-use equilibrium moisture content of the laminated timber will be 16% or more, the moisture content of laminations at the time of bonding shall not exceed 20%. All bonding procedures for lumber with moisture content above 16% shall be qualified according to the requirements of ANSI A190.1. These qualification tests shall be performed using lumber with the maximum moisture content to be qualified (not to exceed 20%).

C3.2 Surfacing and Cleanliness

At the time of bonding, variations in thickness across the width of a lamination shall not exceed plus or minus 0.008 inch (0.2 mm). The variation in thickness along the length of an individual piece of lumber or the lamination shall not exceed plus or minus 0.012 inch (0.3 mm). The thickness variation shall occur randomly across the width and along the length such that the cumulative effect does not contribute to side-to-side depth variations greater than allowed in ANSI A190.1. All bonding surfaces including face, edge and end joints shall be smooth and, except for minor local variations, shall be free of raised grain, torn grain, skip, burns, glazing or other deviations from the plane of the surface that might interfere with the contact of sound wood fibers in the mating surfaces. All bonding surfaces shall be free from dust, foreign matter, and exudation which are detrimental to satisfactory bonding.

When lumber will not be resurfaced prior to laminating, the grading process must contain adequate checks to assure that pieces not conforming to the tolerances stated above are excluded.

When lumber will be resurfaced after grading, pieces which will not, after being surfaced, conform to the tolerances stated above shall be excluded.

C3.3 Knots

Knots shall be permitted to be sound, unsound, or not firmly fixed.

C3.3.1 In or Near End Joints

Knots or knotholes in plane scarf joints shall be limited to those permitted for the lumber grade. In no case shall they exceed 1/4 the nominal width of the piece in laminations occupying the outer 10% on each side of bending members and in any lamination of tension members.

Finger joints shall not contain knots.

In bending members, knots exceeding 3/8-inch (9.5-mm) diameter shall not be permitted within 2 knot diameters or 6 inches (152 mm), whichever is less, of finger joints in the inner and outer tension zones (in no case less than 10% of the depth of bending members). Knots over 1/2-inch (13-mm) diameter shall not be permitted within one knot diameter of finger joints in the balance of the laminations.

In tension members, knots larger than 3/8 inch (9.5 mm) shall not be permitted within 2 knot diameters or 6 inches (152 mm), whichever is less, of finger joints in any lamination.

In compression members, knots larger than 3/4 inch (19 mm) shall not be permitted within one knot diameter of finger joints. Measurement of knot diameter for spacing near end joints shall be parallel to the longitudinal axis of the piece of lumber. The distance of knots from finger joints shall be measured from the edge of the knot nearest the joint to the closest part of the joint.

The grader must consider the end trim plus the length of the fingers, when determining if a knot will be in, or too close to, a finger joint.

C3.4 Knotholes

Knotholes shall be permitted to be the same size as knots permitted in the grade. Other holes shall be permitted if no larger than the allowable knothole.

C3.5 Splits and Shakes

Splits and shakes shall be permitted in all grades if extending from wide faces into the thickness of the piece at an angle of 45° or more from the wide face.

C3.6 Checks

Seasoning checks are permitted.

C3.7 Warp

Warp (including bow, crook and cup) shall not be so great that they will not be straightened out by pressure in bonding. Light crook shall be permitted.

C3.8 Pitch Pockets and Streaks

Medium scattered pitch or bark pockets are permitted in all grades. Pitch streaks shall not exceed 1/6 of the width.

C3.9 Torn Grain

Torn grain up to 1/16 inch (1.6 mm) shall be permitted with some occasional allowance for up to 1/8 inch (3.2 mm).

C3.10 Wane

Light wane which will be removed by resurfacing and therefore not be present in the finished timber shall be permitted at the time of grading. For specific combinations, wane not exceeding 1/6 the width on one or both edges of the wide face of a lamination, as permitted by the layup, shall be permitted in designated grades except that the outer laminations, shall be free of wane.

C3.11 Slope of Grain

Slope of grain of visually graded lumber shall be limited in the full length of each lamination according to the appropriate grade and shall be measured over a distance sufficiently great to determine the general slope, disregarding local deviations, except as noted for special tension laminations.

C3.12 Decay

Decay shall not be permitted, except that firm white speck in limited form may be allowed in some laminating grades as defined herein.

C3.13 Timber Breaks

Timber breaks shall not be permitted.

C3.14 Compression Wood

Compression wood in recognizable form shall be restricted in tension laminations up to 5% of the cross-section if neither damaging nor containing timber breaks. Other lamination grades have specific allowances per grade.

C3.15 Saw kerfs

Saw kerfs shall not be allowed in the outer 5% of the member depth. Other zones shall be permitted to have saw kerfs equal to or less than one-half of the allowable knot size for the grade.

C3.16 Growth Rate

Density of all species, if visually determined, shall be graded according to the following:

- a) Dense (D): Dense lumber shall average not less than 6 annual rings per inch (25 mm) and 1/3 or more summerwood. Pieces averaging less than 6 annual rings per inch (25 mm) but not less than 4 are accepted as dense if averaging 1/2 or more summerwood.
- b) Close (CL): Douglas-Fir-Larch only. Close grain lumber shall have a minimum average of 6 but no more than 30 annual rings per inch (25 mm) with no restriction on the percentage of summerwood. Pieces averaging 5 rings shall be accepted as close grain if averaging 1/3 or more summerwood.
- c) Medium (M): Medium grain lumber shall have 4 or more annual rings per inch (25 mm). In Douglas Fir and southern pine, pieces averaging less than 4 rings per inch (25 mm) are accepted if averaging 1/3 or more summerwood. ~~Medium grain is not defined in the current SPIB Standard Grading Rules, but is required for some laminating grades of southern pine.~~
- d) Coarse (C): SP only. Coarse grain is that which fails to meet the requirements for medium grain. Coarse grain is not defined in the current SPIB Standard Grading Rules, but is permitted for some laminating grades of southern pine.

C4. VISUAL GRADES

C4.1 General Requirements

C4.1.1 Knots

The knot sizes for structural laminating grades of western species are based on a fraction of the dressed width of the piece of lumber. ~~This contrasts with the the~~ knot sizes for structural joists and planks and structural light framing grades of all species, ~~which~~ are tabulated on the basis of the nominal width.

Knots shall be well spaced. "Well spaced" means that the sum of all knots in any 6 inches (152 mm) of length of a piece shall not exceed twice the size of the largest knot permitted, and more than one knot of the maximum permissible size shall not be in the same 6 inches (152 mm) of length. Tension laminations shall be excluded from this rule due to more restrictive spacing requirements.

C4.1.2 Slope of Grain

Slope of grain of visually graded lumber shall be limited in the full length of each lamination and shall be measured over a distance sufficiently great to determine the general slope, disregarding local deviations, except as noted for special tension laminations.

C4.1.3 Density or Growth Rate

Growth rate shall be verified on both ends of visually graded tension laminations. In other visual grades, growth rate is permitted to be assessed by looking at one end of the piece only, except as noted for special tension laminations.

C4.1.4 Specific Gravity of Species

Density or growth rate shall be permitted to be determined by weight using the method described in Section C7. When weight is used to establish growth rate, grades requiring dense rate of growth shall have a specific gravity above the near average specific gravity for the species as shown in the table below.

Species	Near Average, SG at 12% MC
AC	0.42
DF-L	0.46
DF-S	0.50 0.46
HF	0.39
SP	0.49
SPF	0.35
SW	0.32

C4.2 Laminating Grades

C4.2.1 General

In general, laminating grades are designated with an “L,” with the exception of southern pine (which uses “N”). The grade follows, then the density designation. Grades without density designations are considered medium. Example: L1D is laminating grade 1, dense.

C4.2.2 Grade Specific Requirements

In addition to the *General Requirements* outlined in Section C3, and the *General Requirements for Visual Grades* in Section C4.1, the following requirements apply by grade:

C4.2.2.1 L1D

- a) Density: Dense.
Exception: “L1” for Douglas-Fir-Larch/Douglas-Fir South is considered dense. No density designation as per 4.2.2 is required.
- b) Knot Size: Knots shall not occupy more than 1/4 of the cross-section.
- c) Slope of Grain: The basic slope of grain shall not exceed 1:14 for the full length of the piece.

C4.2.2.2 L1

- a) Density: Medium (except Douglas-Fir-Larch/Douglas-Fir South, which is dense).
- b) Knot Size: Knots shall not occupy more than 1/4 of the cross-section.
- c) Slope of Grain: The basic slope of grain shall not exceed 1:14 for the full length of the piece.

C4.2.2.3 L1CL

- a) Density: Close.
- b) Knot Size: Knots shall not occupy more than 1/4 of the cross-section.
- c) Slope of Grain: The basic slope of grain shall not exceed 1:12 for the full length of the piece.

C4.2.2.4 L2D

- a) Density: Dense.
- b) Knot Size: Knots shall not occupy more than 1/3 of the cross-section.
- c) Slope of Grain: The basic slope of grain shall not exceed 1:12 for the full length of the piece
- d) White Speck: Firm white specks are permitted. A combination of white speck and a knot in the same cross-section shall not occupy more than 1/3 the width or equivalent.

C4.2.2.5 L2

- a) Density: Medium.
- b) Knot Size: Knots shall not occupy more than 1/3 of the cross-section.
- c) Slope of Grain: The basic slope of grain shall not exceed 1:12 for the full length of the piece.
- d) White Speck: Firm white specks are permitted. A combination of white speck and a knot in the same cross-section shall not occupy more than 1/3 the width or equivalent.

C4.2.2.6 L3

- a) Density: Medium.
- b) Knot Size: Knots shall not occupy more than 1/2 of the cross-section.
- c) Slope of Grain: The basic slope of grain shall not exceed 1:8 for the full length of the piece.
- d) White Speck: Firm white specks are permitted. A combination of white speck and a knot in the same cross-section shall not occupy more than 1/2 the width or equivalent.

C4.3 Species Specific Requirements—Douglas-Fir-Larch/Douglas-Fir South

Reference herein to Douglas-Fir-Larch shall apply to Douglas-Fir and Western Larch grown within the states of Wyoming, Montana, Idaho, Washington, Oregon and California, because the design values shown are based on a statistical analysis of the growth characteristics of the lumber from these sources.

Reference herein to Douglas-Fir South shall apply to Douglas-Fir grown within the states of Arizona, Colorado, Nevada, New Mexico and Utah because the design values shown are based on a statistical analysis of the growth characteristics of the lumber from these sources.

C4.4 Species Specific Requirements—Hem-Fir

Reference herein to Hem-Fir species shall apply to any one or any combination of the following species: Western Hemlock, Pacific Silver Fir, Noble Fir, Grand Fir, California Red Fir and White Fir, including Hem-Fir grown in Canada.

In addition to the *General Requirements* outlined in Section C3, and the *General Requirements for Visual Grades* in Sections C4.1 and C4.2, the following requirements apply for additional grades:

C4.4.1 SSS

- a) Density: Dense by weight measurement only.
- b) Knot Size: Knots shall not occupy more than 1/10 of the cross-section.
- c) Slope of Grain: The basic slope of grain shall not exceed 1:18 for the full length of the piece.

C4.5 Species Specific Requirements—Softwoods

Reference herein to these species (SW) shall apply to any of the softwood species grown in the United States and Canada having an assigned modulus of elasticity (E) of 1,000,000 psi (6,890 MPa) or more and design values in shear of 135 psi (0.93 MPa) or more for No. 3 structural joists and planks grade based on 19% moisture content. The Softwood Species are those listed in *Standard Grading Rules for Western Lumber* of the Western Wood Products Association, the *Standard Grading Rules for West Coast Lumber* of the West Coast Lumber Inspection Bureau, *Standard Specifications for Grades of California Redwood Lumber* of the Redwood Inspection Service, *Standard Grading Rules for Northeastern Lumber* of the Northeastern Lumber Manufacturers Association or the *Standard Grading Rules for Canadian Lumber* of the National Lumber Grades Authority in Canada.

C4.6 Species Specific Requirements—Southern Pine

Reference herein to “southern pine” shall apply to the four major species of southern pines: Loblolly, Longleaf, Shortleaf and Slash, as defined in the *Southern Pine Inspection Bureau Grading Rules* of the Southern Pine Inspection Bureau (SPIB).

The slope of grain for each grade is the maximum slope of grain allowed for the grade. Lamination requirements for the specified layup may be more restrictive than the basic slope of grain permitted by the grade. Where applicable, the more restrictive requirements apply. This standard (~~ANSI-117~~) specifies slope of grain requirements for a particular lamination.

C4.6.1 N1D

In addition to the *General Requirements* outlined in Section C3, and the *General Requirements for Visual Grades* in Section C4.1, the following requirements apply by grade:

- a) Density: Dense.
- b) Slope of Grain: The basic slope of grain shall not exceed 1:10 for the full length of the piece.
- c) Knot Size:

Width (in.)	4	6	8	10	12
Edge Knot (in.)	1	1-1/2	2	2-1/2	3
Center Knot (in.)	1-1/2	2-1/4	2-3/4	3-1/4	3-3/4

For SI: 1 in. = 25.4 mm

C4.6.2 N1M

In addition to the *General Requirements* outlined in Section C3, and the *General Requirements for Visual Grades* in Section C4.1, the following requirements apply by grade:

- a) Density: Medium.
- b) Slope of Grain: The basic slope of grain shall not exceed 1:10 for the full length of the piece.
- c) Knot Size:

Width (in.)	4	6	8	10	12
Edge Knot (in.)	1	1-1/2	2	2-1/2	3
Center Knot (in.)	1-1/2	2-1/4	2-3/4	3-1/4	3-3/4

For SI: 1 in. = 25.4 mm

C4.6.3 N2D

In addition to the *General Requirements* outlined in Section C3, and the *General Requirements for Visual Grades* in Section C4.1, the following requirements apply by grade:

- a) Density: Dense.
- b) Slope of Grain: The basic slope of grain shall not exceed 1:8 for the full length of the piece.
- c) Knot Size:

Width (in.)	4	6	8	10	12
Edge Knot (in.)	1-1/4	1-7/8	2-1/2	3-1/4	3-3/4
Center Knot (in.)	2	2-7/8	3-1/2	4-1/4	4-3/4

For SI: 1 in. = 25.4 mm

C4.6.4 N2M

In addition to the *General Requirements* outlined in Section C3, and the *General Requirements for Visual Grades* in Section C4.1, the following requirements apply by grade:

- a) Density: Medium.
- b) Slope of Grain: The basic slope of grain shall not exceed 1:8 for the full length of the piece.
- c) Knot Size:

Width (in.)	4	6	8	10	12
Edge Knot (in.)	1-1/4	1-7/8	2-1/2	3-1/4	3-3/4
Center Knot (in.)	2	2-7/8	3-1/2	4-1/4	4-3/4

For SI: 1 in. = 25.4 mm

C4.6.5 N3M

In addition to the *General Requirements* outlined in Section C3, and the *General Requirements for Visual Grades* in Section C4.1, the following requirements apply by grade:

- a) Density: Medium.
- b) Slope of Grain: The basic slope of grain shall not exceed 1:8 for the full length of the piece.
- c) Knot Size:

Width (in.)	4	6	8	10	12
Edge Knot (in.)	1-3/4	2-3/4	3-1/2	4-1/2	5-1/2
Center Knot (in.)	2-1/2	3-3/4	4-1/2	5-1/2	6-1/2

For SI: 1 in. = 25.4 mm

C4.6.6 N3C

In addition to the *General Requirements* outlined in Section C3, and the *General Requirements for Visual Grades* in Section C4.1, the following requirements apply by grade:

- a) Density: Coarse.
- b) Slope of Grain: The basic slope of grain shall not exceed 1:4 for the full length of the piece.
- c) Knot Size:

Width (in.)	4	6	8	10	12
Edge Knot (in.)	1-3/4	2-3/4	3-1/2	4-1/2	5-1/2
Center Knot (in.)	2-1/2	3-3/4	4-1/2	5-1/2	6-1/2

For SI: 1 in. = 25.4 mm

C4.7 Grade Specific Requirements—Alaska Cedar

Reference herein to this species shall apply to Alaska Cedar grown in the United States or Canada.

In addition to the *General Requirements* outlined in Section C3, and the *General Requirements for Visual Grades* in Sections C4.1 and 4.2, the following additional requirements/exceptions apply by grade:

C4.7.1 L1S

- a) Density: Dense.
- b) Knot Size: Knots shall not occupy more than 1/4 of the cross-section. A cross section shall be defined as any one-foot (305-mm) length.
- c) Slope of Grain: The basic slope of grain shall not exceed 1:14 for the full length of the piece.

C4.7.2 L1D

- a) Density: Dense.
- b) Knot Size: Knots shall not occupy more than 1/4 of the cross-section. A cross section shall be defined as any one-foot (305-mm) length.
- c) Slope of Grain: The basic slope of grain shall not exceed 1:12 for the full length of the piece.

C4.8 Grade Specific Requirements—California Redwood

Reference to this species herein applies to Redwood manufactured from timber grown within the Northern California coastal area as defined in the *Standard Specifications for Grades of California Redwood Lumber* of the Redwood Inspection Service. The design values shown herein are based on a statistical analysis of the growth characteristics of the lumber from this source.

Laminating lumber shall be of Redwood graded in accordance with the *Standard Specifications for Grades of California Redwood Lumber* of the Redwood Inspection Service.

There are five structural laminating grades of Redwood used for laminating purposes: “L1,” clear-Clear all-All heart Heart laminatingLaminating; “L2,” clear-Clear laminatingLaminating; “L3,” select-Select heart Heart laminatingLaminating; “L4,” construction-Construction heart-Heart laminatingLaminating; and “L5,” construction Construction Common laminatingLaminating. See the above referenced standard for grading rules and specific requirements.

C5. E-RATED GRADES (OTHER THAN 302 TENSION LAMINATIONS)

C5.1 General

E-rated laminating lumber is lumber that has been selected by nondestructive measurement and by visual inspection for compliance with the grade stiffness and manufacturing requirements of Section C3. An E-rated laminating lumber grade includes pieces with edge characteristics (knots, knotholes, burls, distorted grain) up to the maximum size allowed for use with the grade in any laminated timber ~~lay-up~~ layup combination. E-rated lumber has additional visual restrictions for portions of the lumber not evaluated for stiffness.

C5.2 Long-Span E (LSE)

Long-span E or LSE as defined herein shall be used as the standard nomenclature for specifying E values of E-rated laminating lumber.

C5.2.1 Definition

Long-span E is defined as the Modulus of Elasticity (MOE) calculated from deflection measured in a flat-wise static bending test of lumber with center point loading and a span-depth ratio (l/d) of approximately 100.

C5.2.2 Measurement

Long-span E shall be measured by the procedures of ASTM D4761, *Bending Flatwise-Center Point Loading*.

C5.2.3 Lumber Production

E-rated laminating lumber shall be permitted to be produced with a system that measures MOE by means other than direct Long-span E measurement. Production equipment used to measure MOE shall be calibrated to produce E-rated laminating lumber grades meeting the Long-span E requirements of those grades. For purposes of calibration, Long-span E shall be measured by the procedures of ASTM D4761, *Bending Flatwise- Center Point Loading*.

C5.3 E-Rated Laminating Lumber Specifications

C5.3.1 Grade Names

E-rated laminating lumber grades shall be designated by the mean MOE of the grade, which is the mean Long-span E requirement of the grade, the word “LAM,” and the denominator of allowable edge knot fraction. For example, a grade with a mean Long-span E requirement of 1,900,000 psi (13,100 MPa) and an allowable 1/3 edge characteristic will be named “1.9E LAM-3.” For reasons of spacing on a grade stamp, this is permitted to be shortened to 1.9E-3 on a stamp.

C5.3.2 E Specifications for E-rated Lumber for Qualification

C5.3.2.1 Mean Long-Span E

If the sample size is less than 125, the mean Long-span E of the lumber shall equal or exceed the specified grade mean MOE. Alternatively, if the sample size equals or exceeds 40, the mean Long-span E of the sample, E_t , shall meet the following criteria:

$$E_t \geq E_s - 1.303 (S_t / \sqrt{n_t})$$

where:

S_t = the estimated population standard deviation (10^6 -psi or MPa)

$S_t = (E_t - E_{st}) / 0.684$ (10^6 -psi or MPa)

n_t = sample size (≥ 40)

E_t = mean long-span E of the sample (10^6 -psi or MPa)

E_s = grade long-span E (10^6 -psi or MPa)

E_{st} = 5th percentile long-span E calculated from the test data (10^6 -psi or MPa)

C5.3.2.2 MOE Distribution

The distribution of MOE values within an E-rated lumber grade shall be such that the 5th percentile value shall be equal to or greater than the grade 5th percentile values as shown in the table below.

Long-Span E Specification		
Grade	Mean (10^6 psi)	5th Percentile (10^6 psi)
2.6E LAM	2.6	2.26
2.5E LAM	2.5	2.16
2.4E LAM	2.4	2.06
2.3E LAM	2.3	1.96
2.2E LAM	2.2	1.86
2.1E LAM	2.1	1.77
2.0E LAM	2.0	1.67
1.9E LAM	1.9	1.58
1.8E LAM	1.8	1.48
1.7E LAM	1.7	1.39
1.6E LAM	1.6	1.30
1.5E LAM	1.5	1.21

For SI: 10^6 psi = 6,890 MPa

C5.3.3 Visual Limitations

C5.3.3.1 Edge Characteristics

Characteristics such as knots, knotholes, burls, and distorted grain occurring at the edges of the wide faces shall be measured and limited to a fraction of the cross section in conformance with American Lumber Standards approved procedures in the following categories:

Edge Characteristics	Codes
1/6	6
1/4	4
1/3	3
1/2	2

C5.3.3.2 Untested Portions

Portions of the lumber not tested by the E-rating device shall conform to the following visual limitations:

- Non-Edge Knots equal to the largest non-edge knots in the tested portion of the piece or the next larger edge knot, whichever is greater.
- Cross-Section Knots: Displacement of all knots in the same cross section shall not exceed the size of the permitted non-edge knot.
- Slope of Grain: The general slope of grain in the untested portion shall not be steeper than:

Slope	Edge Characteristic (Disp.)
1 in 12	1/6
1 in 10	$> 1/6$ to $\leq 1/4$
1 in 8	$> 1/4$

C5.4 Production Quality Control

C5.4.1 Supervision

Quality control of E-rated laminating lumber shall be under the supervision of an accredited third-party inspection agency.

C5.4.2 Quality Control

C5.4.2.1 Formal Quality Control Program Required

A formal quality control program shall be maintained at the production facility to provide conformance to grade specifications on a continuous basis. The quality control program shall be approved by an accredited third-party inspection agency.

C5.4.2.2 E-rated Grade Edge Characteristics

The edge characteristic restrictions applied for ~~lay-up~~layup shall not be required to be considered when establishing the MOE criteria for quality control of an E-rated laminating lumber grade or when evaluating a given lot of E-rated laminating lumber for conformance to the E specifications of the grade of the lot.

C5.4.2.3 Quality Control Records

Quality control records shall be maintained at the lumber production facility for a minimum of five (5) years.

C5.5 Reinspection of Individual Lots for Conformance to Specifications

C5.5.1 Test Method and Evaluation

The procedures of AITC Test T124 shall be used for testing and evaluating individual lots of E-rated laminating lumber for conformance to grade specifications.

C5.5.2 Disposition of Nonconforming Lots

C5.5.2.1 Regrade

The lumber shall be permitted to be regraded by testing all of the pieces in the lot in accordance with the Long-span E testing procedures of ASTM D4761, *Bending Flatwise-Center Point Loading*, and eliminating low E pieces from the lot so that the specifications for mean and lower 5th percentile E values of the E-rated grade are met. If the lumber is regraded by commercial testing devices other than a Long-span E measuring device, conformance to grade specifications shall be verified by AITC Test T124.

C5.5.2.2 Assign a Lower Grade Level

The lumber shall be permitted to be used at a lower E-rated grade level for which the lot was qualified by the test results.

C6. SPECIAL TENSION LAMINATION GRADES

C6.1 General

There are six (6) grades of tension laminations, 302-20, 302-22, 302-24, 302-26, 302-28 and 302-30. The following general restrictions and limiting provision apply to all grades and sizes of lumber graded as tension laminations:

C6.1.1 Cross Section

A one-foot (305-mm) length of a lamination shall be considered as a cross section.

C6.1.2 Density

Growth rate requirements shall apply to the full length of the piece. All tension laminations shall be dense. Each piece shall have a specific gravity greater than the near average specific gravity for the species. See Section C4.1.4 for the near average specific gravity by species.

Exception: Certain exceptions apply as shown in the *Alternate Rules* for each grade below.

C6.2 302-20

C6.2.1 Primary Rules (All Species)

C6.2.1.1 General

In addition to the basic requirements of the grades tabulated in these specifications, the following limitations shall apply to all 302-20 grades under the primary rules of grading:

- a) Knots shall not occupy more than 1/4 of the width in any cross section.
- b) The general slope of grain shall not be steeper than 1:12. Where more restrictive slope of grain is required by the laminating combinations, the more restrictive slope of grain shall apply.
- c) Any cross-section shall have at least 50% clear wood free of strength-reducing characteristics with a slope of grain no steeper than 1:12. Knots plus associated localized cross grain, knots plus associated localized cross grain plus localized cross grain not associated with a knot, or localized cross grain not associated with a knot are permitted to occupy up to 1/2 of the cross-section.

C6.2.1.2 Visually Graded Combinations

In addition to the provisions in Section C6.2.1.1, the following applies to visually graded combinations:

- a) Pieces containing wide-ringed or lightweight pith-associated wood at the ends of the piece occupying over 1/8 of the cross section shall be excluded. The next inch (25 mm) of wood outside the area of the pith-associated wood shall be dense. The line along which measurement of this inch (25 mm) is made shall correspond to the line used in the standard grading rules for rate of growth and percentage of summerwood. If a distance of one inch (25 mm) is not available along this line, the measurement will be made over such lesser portion as exists.

C6.2.1.3 E-Rated Combinations

In addition to the provisions in Section C6.2.1.1, the following applies to E-rated combinations:

- a) Laminations for E-rated combinations shall be visually graded and E-rated in accordance with all of the requirements for the E-rated grade shown for the outer tension laminations.
- b) Pieces containing wide-ringed or lightweight pith-associated wood at the ends of the piece occupying over 1/8 of the cross section shall be excluded. All wood not included as pith-associated wood shall be at least medium grain rate of growth

C6.2.2 Alternate Rules

C6.2.2.1 Douglas-Fir-Larch

Exceptions to provisions in Section C6.2.1 are allowed for Douglas-Fir-Larch 302-20 tension laminations as follows. Provisions not listed here are not excepted:

- a) Knots shall not exceed the size listed in the following chart:

Nominal width, in.	4	6	8	10	12
Knot size, in.	3/8	1/2	3/4	7/8	1

For SI: 1 in. = 25.4 mm

- b) Any cross-section shall have at least 3/4 clear wood free of strength-reducing characteristics. Knots plus associated localized cross grain, knots plus associated localized cross grain plus localized cross grain not associated with a knot, or localized cross grain not associated with a knot are permitted to occupy up to 1/4 of the cross section.
- c) Slope of grain shall not be steeper than 1:10.
- d) Pieces shall have a specific gravity of 0.45 or above based on oven-dried weight and volume at 12% moisture content.
- e) **End Joint Qualification:** Manufacturers using these alternative tension lamination provisions shall qualify their end joint by testing 30 end joints containing the maximum slope of grain to be used in the plant for this grade up to 1:10. Test procedures and criteria for acceptance of this test are as contained in ASTM D7469 and ANSI A190.1.

C6.2.2.2 E-Rated

The following are alternative provisions for E-rated tension laminations. Laminations shall be visually graded and E-rated in accordance with all of the requirements for the E-rated grade shown for the outer tension laminations, except where specifically modified in this section. Lumber shall be from an E-rating system which employs continuously measured lowest point modulus of elasticity. In addition to these basic requirements the following limitations shall apply:

- a) Centerline knots shall not occupy more than 1/4 of the cross section.
- b) Edge knots are limited to that allowed by the E-rated grade.
- c) **Special Provisions for Ends of Piece:** In addition to the visual requirements above, the untested portion(s) of each piece shall be visually graded to meet the following:
 1. The untested portion(s) of the piece shall have the same general character as the remainder of the piece.
 2. The general slope of grain shall not be steeper than 1:12.
 3. Any cross-section shall have at least 1/2 clear wood free of strength reducing characteristics.
- d) **Testing Provisions:** When this alternative provision is used the lumber shall be tested and qualified in accordance with AITC Test T123. Criteria for acceptance shall be that the 5th percentile with 75% confidence determined by AITC Test T123 shall equal or exceed 3,340 psi (23.0 MPa).
- (e) **Application:** Tension laminations qualified under this alternate provision are permitted to be used for all visually graded combinations without regard to the Long-span E provided the compression perpendicular to grain design values are satisfied.

C6.3 302-22

C6.3.1 Primary Rules (All Species)

C6.3.1.1 General

In addition to the basic requirements of the grades tabulated in these specifications, the following limitations shall apply to all 302-22 grades under the primary rules of grading:

- a) Knots shall not occupy more than 1/4 of the width in any cross-section.
- b) Any cross-section shall have at least 60% clear wood free of strength-reducing characteristics with a slope of grain no steeper than 1:16. Knots plus associated localized cross grain, or knots plus associated localized cross grain plus associated cross grain not associated with a knot, or localized cross grain not associated with a knot are permitted to occupy up to 40% of the cross-section.
- c) The general slope of grain shall not be steeper than 1:16. Where more restrictive slope of grain is required by the laminating combinations, the more restrictive slope of grain shall apply.

C6.3.1.2 Visually Graded Combinations

In addition to the provisions in Section 6.3.1.1, the following applies to visually graded combinations:

- a) Pieces containing wide-ringed or lightweight pith-associated wood at the ends of the piece occupying over 1/8 of the cross-section shall be excluded. The next inch (25 mm) of wood outside the area of the pith-associated wood shall meet the growth rate requirements of the grade, including “dense” when dense laminations are required. The line along which measurement of this inch (25 mm) is made shall correspond to the line used in the standard grading rules for rate of growth and percentage of summerwood. If a distance of one inch (25 mm) is not available along this line, the measurement will be made over such lesser portion as exists.

C6.3.1.3 E-Rated Combinations

In addition to the provisions in Section 6.3.1.1, the following applies to E-rated combinations:

- a) Laminations shall be visually graded and E-rated in accordance with all of the requirements for the E-rated grade shown for the outer tension laminations.
- b) Pieces containing wide-ringed or lightweight pith-associated wood at the ends of the piece occupying over 1/8 of the cross section shall be excluded. All wood not included as pith-associated wood shall be of at least medium grain rate of growth.

C6.3.2 Alternate Rules

C6.3.2.1 Douglas-Fir-Larch

Exceptions to provisions in Section 6.3.1 are allowed for Douglas-Fir-Larch 302-22 tension laminations as follows.

Provisions not listed here are not excepted:

- a) Knots shall not exceed the size listed in the following chart:

Nominal width, in.	4	6	8	10	12
Knot size, in.	3/8	1/2	3/4	7/8	1

For SI: 1 in. = 25.4 mm

- b) Any cross-section shall have at least 3/4 clear wood free of strength-reducing characteristics. Knots plus associated localized cross grain, knots plus associated localized cross grain plus localized cross grain not associated with a knot, or localized cross grain not associated with a knot are permitted to occupy up to 1/4 of the cross section.
- c) Slope of grain shall not be steeper than 1:16.
- d) Growth rate requirements shall apply to the full length of the piece. Douglas-Fir-Larch tension laminations are required to have at least an average of six annual rings per inch (25 mm). Pieces shall have a specific gravity of 0.35 or above based on oven-dried weight and volume of 12% moisture content. This tension lamination provides a compression perpendicular to grain design value of 590 psi. Where required to have 650 psi compression perpendicular to grain design value, at least one dense two-inch nominal thickness lamination is required in the bearing area.
- e) **End Joint Qualification:** Manufacturers using these alternative tension lamination provisions shall qualify their end joint by testing 30 end joints containing the maximum slope of grain to be used in the plant for this grade up to 1:16. Test procedures and criteria for acceptance of this test are as contained in ASTM D7469 and ANSI A190.1.

C6.3.2.2 Douglas-Fir-Larch

Exceptions to provisions in Section 6.3.1 are allowed for Douglas Fir-Larch 302-22 tension laminations as follows. Provisions not listed here are not excepted:

- a) Knots shall not exceed the size listed in the following chart:

Nominal width, in.	4	6	8	10	12
Knot size, in.	3/8	1/2	3/4	7/8	1

For SI: 1 in. = 25.4 mm

- b) Any cross-section shall have at least 3/4 clear wood free of strength-reducing characteristics. Knots plus associated localized cross grain, knots plus associated localized cross grain plus localized cross grain not associated with a knot, or localized cross grain not associated with a knot are permitted to occupy up to 1/4 of the cross section.
- c) Slope of grain shall not be steeper than 1:12.
- d) Growth rate requirements shall apply to the full length of the piece. Douglas-Fir-Larch tension laminations are required to have at least an average of 6 annual rings per inch (25 mm). This tension lamination provides a compression perpendicular to grain design value of 590 psi (4.1 MPa). Where required to have 650 psi (4.5 MPa) compression perpendicular to grain design value, at least one dense two-inch nominal thickness lamination is required in the bearing area.
- e) The long-span modulus of elasticity shall not be less than 1,700,000 psi (11,700 MPa).
- f) **End Joint Qualification:** Manufacturers using these alternative tension lamination provisions shall qualify their end joint by testing 30 end joints containing the maximum slope of grain to be used in the plant for this grade up to 1:12. Test procedures and criteria for acceptance of this test are as contained in ASTM D7469 and ANSI A190.1.

C6.3.2.3 E-rated

The following are alternative provisions for E-rated tension laminations. Laminations shall be visually graded and E-rated in accordance with all of the requirements for the E-rated grade shown for the outer tension lamination, except where specifically modified in this section. Lumber shall be from an E-rating system which employs continuously measured lowest point modulus of elasticity. In addition to these basic requirements the following limitations shall apply:

- a) Centerline knots shall not occupy more than 1/4 of the cross section.
- b) Edge knots are limited to that allowed by the E-rated grade.
- c) **Special Provisions for Ends of Piece:** In addition to the visual requirements above, the untested portion(s) of each piece shall be visually graded to meet the following:
 1. The untested portion(s) of the piece shall have the same general character as the remainder of the piece.
 2. The general slope of grain shall not be steeper than 1:12.
 3. Any cross-section shall have at least 60% clear wood free of strength reducing characteristics.
- d) **Testing Provisions:** When this alternative provision is used the lumber shall be tested and qualified in accordance with AITC Test T123. Criteria for acceptance shall be that the 5th percentile with 75% confidence determined by AITC Test T123 shall equal or exceed 3,670 psi (25.3 MPa).
- e) **Application:** Tension laminations qualified under this alternate provision are permitted to be used for all visually graded combinations without regard to the Long-span E provided the compression perpendicular to grain design values are satisfied.

C6.4 302-24

C6.4.1 Primary Rules

C6.4.1.1 General

In addition to the basic requirements of the grades tabulated in these specifications, the following limitations shall apply to all 302-24 grades under the primary rules of grading:

- a) Knots shall not occupy more than 1/5 of the width in any cross section.
- b) Any cross-section shall have at least 2/3 clear wood free of strength-reducing characteristics with a slope of grain no steeper than 1:16. Knots plus associated localized cross grain, knots plus associated localized cross grain plus localized cross grain not associated with a knot, or localized cross grain not associated with a knot are permitted to occupy up to 1/3 of the cross-section.
- c) Maximum size single strength-reducing characteristics when not in the same horizontal projection shall be at least two feet (610 mm) apart measured center to center.
- d) The general slope of grain shall not be steeper than 1:16. Where more restrictive slope of grain is required by the laminating combinations, the more restrictive slope of grain shall apply.

C6.4.1.2 Visually Graded Combinations

In addition to the provisions in Section C6.4.1.1, the following applies to visually graded combinations:

- a) Pieces containing wide-ringed or lightweight pith-associated wood at the ends of the piece occupying over 1/8 of the cross section shall be excluded. The next inch (25 mm) of wood outside the area of the pith-associated wood shall meet the growth rate requirements of the grade, including “dense” when dense laminations are required. The line along which measurement of this inch (25 mm) is made shall correspond to the line used in the standard grading rules for rate of growth and percentage of summerwood. If a distance of one inch (25 mm) is not available along this line, the measurement will be made over such lesser portion as exists.

C6.4.1.3 E-Rated Combinations

In addition to the provisions in Section C6.4.1.1, the following applies to E-rated combinations:

- a) Laminations shall be visually graded and E-rated in accordance with all of the requirements for the E-rated grade shown for the outer tension lamination.
- b) Pieces containing wide-ringed or lightweight pith-associated wood at the ends of the piece occupying over 1/8 of the cross section shall be excluded. All wood not included as pith-associated wood shall be at least medium grain rate of growth.

C6.4.2 Alternate Rules

C6.4.2.1 Douglas-Fir-Larch

Exceptions to provisions in C6.4.1 are allowed for Douglas-Fir-Larch 302-24 tension laminations as follows.

Provisions not listed here are not excepted:

- a) Knots shall not exceed the size listed in the following chart:

Nominal width, in.	4	6	8	10	12
Knot size, in.	3/8	1/2	3/4	7/8	1

For SI: 1 in. = 25.4 mm

- b) Any cross-section shall have at least 3/4 clear wood free of strength-reducing characteristics. Knots plus associated localized cross grain, knots plus associated localized cross grain plus localized cross grain not associated with a knot, or localized cross grain not associated with a knot are permitted to occupy up to 1/4 of the cross-section.
- c) Maximum size single strength-reducing characteristics when not in the same horizontal projection shall be at least 2 feet (610 mm) apart measured center to center.
- d) Slope of grain shall not be steeper than 1:12.
- e) The long-span modulus of elasticity shall not be less than 1,800,000 psi (12,400 MPa).
- f) **End Joint Qualification:** Manufacturers using these alternative tension lamination provisions shall qualify their end joint by testing 30 end joints containing the maximum slope of grain to be used in the plant for this grade up to 1:12. Test procedures and criteria for acceptance of this test are as contained in ASTM D7469 and ANSI A190.1.

C6.4.2.2 E-rated

The following are alternative provisions for E-rated tension laminations. Laminations shall be visually graded and E-rated in accordance with all of the requirements for the E-rated grade shown for the outer tension lamination, except where specifically modified in this section. Lumber shall be from an E-rating system which employs continuously measured lowest point modulus of elasticity. In addition to these basic requirements the following limitations shall apply:

- a) Centerline knots shall not occupy more than 1/5 of the cross section.
- b) Maximum size single strength-reducing characteristics when not in the same horizontal projection shall be at least two feet (610 mm) apart measured center to center.
- c) Edge knots are limited to that allowed by the E-rated grade.
- d) **Special Provisions for Ends of Piece:** In addition to the visual requirements above, the untested portion(s) of each piece shall be visually graded to meet the following:
 1. The untested portion(s) of the piece shall have the same general character as the remainder of the piece.
 2. The general slope of grain shall not be steeper than 1:12.
 3. Any cross-section shall have at least 2/3 clear wood free of strength-reducing characteristics.
- e) **Testing Provisions:** When this alternative provision is used the lumber shall be tested and qualified in accordance with AITC Test T123. Criteria for acceptance shall be that the 5th percentile with 75% confidence determined by AITC Test T123 shall equal or exceed 4,000 psi (27.6 MPa).
- f) **End Joint Qualification:** Manufacturers using these alternative tension lamination provisions shall qualify their end joint by testing 30 end joints containing the maximum slope of grain to be used in the plant for this grade up to 1:12. Test procedures and criteria for acceptance of this test are as contained in ASTM D7469 and ANSI A190.1.
- g) **Application:** Tension laminations qualified under this alternate provision are permitted to be used for all visually graded combinations without regard to the Long-span E provided the compression perpendicular to grain design values are satisfied.

C6.5 302-26

C6.5.1 Primary Rules

In addition to the basic requirements of the 302-24 lamination grade as tabulated in Section C6.4, the following limitations shall apply:

- a) Any cross-section containing an edge knot shall have 80% clear and straight-grained wood.

C6.6 302-28

C6.6.1 Primary Rules

In addition to the basic requirements of the 302-24 lamination grade as tabulated in Section C6.4, the following limitations shall apply:

- a) Average Long-span E for the grade shall be 2.3×10^6 psi (15,900 MPa) with no piece less than 1.96×10^6 psi (13,500 MPa) and shall be verified through daily quality control.

C6.7 302-30

C6.7.1 Primary Rules

In addition to the basic requirements of the 302-26 lamination grade as tabulated in Section C6.5, the following limitations shall apply:

- a) Average Long-span E for the grade shall be 2.3×10^6 psi (15,900 MPa) with no piece less than 1.96×10^6 psi (13,500 MPa) and shall be verified through daily quality control.

C6.8 Alternate Rules by Species

C6.8.1 Southern Pine

Exceptions to provisions in Sections C6.2, C6.3 and C6.4 are allowed for southern pine as follows. Provisions not listed here are not excepted:

- a) Knots shall not exceed the size listed in the following chart:

Nominal width, in.	4	6	8	10	12
Knot size, in.	3/8	1/2	3/4	7/8	1

- b) Any cross-section shall have at least 3/4 clear wood free of strength-reducing characteristics. Knots plus associated localized cross grain, or knots plus associated localized cross grain not associated with a knot, or localized cross grain not associated with a knot is permitted to occupy up to 1/4 of the cross-section.
- c) Slope of grain shall be no steeper than 1:10 for 302-20 and 1:12 for 302-22 and 302-24.
- d) **End Joint Qualification:** Manufacturers using these alternative tension lamination provisions shall qualify their end joint by testing 30 end joints containing the maximum slope of grain to be used in the plant for this grade up the maximum allowable for said grade. Test procedures and criteria for acceptance of this test are as contained in ASTM D7469 and ANSI A190.1.

C6.8.2 E-Rated Hem Fir

The following are alternative provisions to those included in Sections C6.1, C6.2 and C6.3 for E-rated Hem-Fir tension laminations:

- a) Laminations shall be visually graded and E-rated in accordance with all of the requirements for the E-rated grade tabulated in these specifications for the outer tension lamination except where specifically modified in this section.
- b) Laminations shall conform to WCLIB Standard No. 17, paragraph 101-c, except that the 3-inch (76-mm) cutout provision does not apply.

- c) The knot size permitted for all widths is a small knot (3/4-inch **or 19-mm** diameter). The number of 3/4-inch **(19-mm)** knots permitted is proportionate to the size of the piece of lumber in accordance with paragraph 101-c of WCLIB Standard No. 17.
- d) The 1/6th edge knot characteristic restriction shall be applied to nominal 4-inch wide lumber. For 302-24, 2.0E-1/6 grade is required, for 302-22, 1.8E-1/6 grade is required and for 302-20, 1.5E-1/4 grade is required.
- e) Any cross-section shall have at least 2/3 clear wood free of strength-reducing characteristics. Knots plus associated localized cross grain, knots plus associated localized cross grain plus localized cross grain not associated with a knot, or localized cross grain not associated with a knot are permitted to occupy up to 1/3 of the cross-section
- f) Slope of grain shall be no steeper than 1:12.
- g) For 302-24 grade, maximum size single strength-reducing characteristics when not in the same horizontal projection shall be at least two feet **(610 mm)** apart measured center to center.
- h) **Special Provisions for Ends of Piece:** The untested portion of each end of each piece shall be visually graded to meet the following:
 1. The ends of the piece shall have the same general character as the remainder of the piece.
 2. Any cross-section shall have at least 1/2, 3/5 or 2/3 clear wood free of strength-reducing characteristics for 302-20, 302-22 or 302-24 respectively. Knots plus associated localized cross grain, knots plus associated localized cross grain plus localized cross grain not associated with a knot, or localized cross grain not associated with a knot are permitted to occupy up to 1/2, 2/5 or 1/3 of the cross-section for 302-20, 302-22 and 302-24, respectively.
- i) **End Joint Qualification:** Manufacturers using these alternative tension lamination provisions shall qualify their end joint by testing 30 end joints containing the maximum slope of grain to be used in the plant for this grade up to 1:12. Test procedures and criteria for acceptance of this test are as contained in ASTM D7469 and ANSI A190.1.
- j) **Testing Provisions:** The provisions for end joint qualification for clear wood at a cross-section and general slope of grain is permitted to be eliminated if a test is conducted in accordance with AITC Test T123 to verify the strength of lumber from the E-rating system which employs continuously measured lowest point modulus of elasticity. Criteria for acceptance shall be that the 5th percentile with 75% confidence determined by AITC Test T123 shall equal or exceed the following values:

Grade	Test Value 5th Percentile, psi
302-24	4,000
302-22	3,670
302-20	3,340

For SI: 1 psi = 6,890 Pa

C6.9 C-14: Alternate Provision for Machine-Graded Tension Laminations

C6.9.1 General

This alternate provision covers lumber mechanically graded under the provisions of the American Lumber Standard **(ALS)**. These grades shall be qualified and quality controlled by test for strength and stiffness by an agency **qualified-accredited** by **the American Lumber Standard Committee's Board of Review ALS**. These grades include machine stress-rated lumber (MSR) and machine-evaluated lumber (MEL). Machine-graded lumber is lumber manufactured with the use of grading methodologies that include the use of machines for identifying mechanical properties in the grading process. This alternate provision shall be applied to lumber from each machine grading facility and grading system seeking qualification for production of tension laminations to be used on structural glued laminated timber, with grades equivalent to the 302-20, 302-22 and 302-24 grades required. Machine-graded lumber to be used under this alternate

provision shall meet specific product descriptions as defined in the various standards. Qualification records shall be maintained at the facility where carried out and shall be available for review by the accredited third-party inspection agency of the laminator.

Lumber to be qualified for tension laminations under this alternate provision shall be manufactured by a facility qualified to produce machine-graded lumber under the supervision of a grading agency accredited by the American Lumber Standards Committee. This grading practice shall meet the quality control provision of such a grading agency and include quality control for tensile strength and Long-span E properties.

C6.9.2 *Visual Grading*

The general visual requirements for machine-graded lumber plus any additional visual limitations required by the supervisory grading agency for qualification under the provisions shall apply. In addition, the general lumber requirements contained in Section C3 shall apply.

C6.9.3 *Special Visual Grading Requirements*

The supervisory grading agency shall provide appropriate visual limitations applicable to those portions of pieces not subjected to machine grading which will assure that the tensile strength requirements of the grade are maintained. For this purpose, these rules are permitted to be those applied in Sections C6.2, C6.3 and C6.4 to obtain grades equivalent to 302-20, 302-22 and 302-24.

C6.9.4 *Quality Control*

The quality control requirements of this alternate tension lamination material are the responsibility of the lumber producer under the supervision of a grading agency accredited by the American Lumber Standards Committee. Records for the respective quality control responsibilities shall be maintained at the facility where carried out and shall be available for periodic review by the lumber grading agency and the accredited third-party inspection agency of the laminator.

If the lumber is supplied to the laminator as meeting the requirements of Sections C2, C6.7.1 and C6.7.2, all mechanical and visual inspection and quality control requirements shall be the responsibility of the machine grading facility.

If lumber is supplied to the laminator as meeting only the mechanical and visual stress grading criteria of Section C6.7.1, those inspection and quality control requirements shall be the responsibility of the machine grading facility; however, the laminator shall be responsible for the additional visual grading required to meet the laminating criteria of this standard.

C6.9.5 *Identification*

Each piece of machine-graded lumber used under this alternative provision shall be grade stamped with the appropriate stamp of the supervisory lumber grading agency.

C6.9.6 *Changes in Practice*

If, in the judgment of the accredited third-party inspection agency of the laminator, significant changes are made in the visual or machine grading practice, the qualification prescribed herein shall be invalid and shall be re-qualified.

C6.9.7 Testing Provisions

When this alternative provision is used, the lumber shall be qualified for tensile strength and Long-span E using a sample size of not less than 102 pieces. The testing procedures of AITC Test T123 shall be used for testing tensile properties. The testing procedures of ASTM D4761, Bending Flatwise-Center Point Loading, shall be used for testing Long-span E.

C6.9.8 Criteria for Acceptance

C6.9.8.1 Tensile Strength Qualification

For qualification for a tension lamination grade, the 5th percentile tensile strength estimated with 75 percent confidence shall equal or exceed the values calculated as follows:

Grade	Test Value 5th Percentile, psi
302-24	4,000
302-22	3,670
302-20	3,340

For SI: 1 psi = 6,890 Pa

Tension laminations for beams 6 inches (152-mm) or less in width and greater than 15 inches (381 mm) in depth shall meet or exceed 1.67 times the beam design value in bending, F_{bx} . The values established in this way are then adjusted for lamination width by multiplying by the factors of 0.95, 0.90 and 0.84 for nominal 8, 10 and 12 inches widths respectively. These values are then reduced for beams of lesser depth by multiplying by factors of 0.90 for beams 12 inches (305 mm) to 15 inches (381 mm) in depth and 0.80 for beams less than 12 inches (305 mm) in depth.

C6.9.8.2 End Joint Qualification

Manufacturers using tension laminations qualified under this alternative provision shall qualify the end joints by following procedures in ASTM D7469 by testing 30 end joints in tension made from representative lumber from the machine-grading system.

C6.9.9 Application

Tension laminations qualified under this alternative provision are permitted to be used for all visually graded and E-rated combinations provided the average Long-span E of the laminations is at least equal to the average Long-span E of the grade of lumber for which it is being substituted and the compression perpendicular to grain design values are satisfied.

C6.9.10 Reinspection and Testing of Individual Lots for Conformance to Specifications

The procedures of the grading agency supervising the production of the lumber shall be used for re-inspecting individual lots for conformance to specifications.

C6.9.11 Records

The grading agency that supervises qualification to the provisions of C-14 shall report a summary of the qualification results to the accredited third-party inspection agency of the laminator.

C7. METHOD FOR DETERMINATION OF SPECIFIC GRAVITY

C7.1 General

Measuring specific gravity of a piece of lumber shall be permitted to be used to determine density for all softwood species used for laminating, and shall be required to be used for dense Hem-Fir, since ring count and percent summerwood do not provide a reliable measure of density for Hem-Fir.

In determining specific gravity, lumber is weighed and a weight per volume is calculated. From this number the specific gravity can be calculated. In weighing lumber to determine specific gravity, several factors shall be taken into account: moisture content of the lumber; width, thickness and length; and accuracy of the measurements.

C7.2 Moisture Content

Moisture contents shall be measured with a moisture meter calibrated for the species being tested. The moisture content of lumber at the time of weighing shall be taken into account in determining whether or not a piece meets the minimum weight requirements for the species. The range of moisture content of lumber used for laminating is relatively small. However, in the preparation of charts to use in production, the minimum weights for 8%, 12% and 16% moisture content are recommended. Minimum weights for intermediate moisture contents may be interpolated.

C7.3 Size

The thickness and width of lumber shall be maintained according to ANSI A190.1 tolerances, and measured to the nearest 0.01 inch (0.25 mm) at the time of weighing. Length shall be measured to the nearest 1/8 inch (3.2 mm).

C7.4 Method of Weighing

Any method of weighing the nearest 0.01 lbf (0.044 N) is satisfactory.

C7.5 Calculation of Specific Gravity

Calculation of specific gravity shall be normalized to 12% moisture content in order to compare it to the required levels. ASTM D2395 shall be used to calculate specific gravity.

REFERENCES

1. AITC/WCLIB. 2009. *Standard 200. Manufacturing Quality Control Systems Manual*. West Coast Lumber Inspection Bureau. Portland, Oregon.
2. AITC. 2012. *Timber Construction Manual*. 6th ed. John Wiley & Sons. New York, New York.
3. ANSI. 2012. ANSI A190.1. *American National Standard for Wood Products—Structural Glued Laminated Timber*. APA—The Engineered Wood Association. Tacoma, Washington.
4. ANSI. 2012. ANSI O5.2. *American National Standard for Wood Products—Structural Glued Laminated Timber for Utility Structures*. American Wood Protection Association. Birmingham, Alabama.
5. APA. 2015. *Quality Assurance Policy for Structural Glued Laminated Timber*. APA—The Engineered Wood Association. Tacoma, Washington.
6. ASTM. 2014. Standard D143. *Standard Test Methods for Small Clear Specimens of Timber*. ASTM International. West Conshohocken, Pennsylvania.
7. ASTM. 2014. Standard D2395. *Standard Test Methods for Density and Specific Gravity (Relative Density) of Wood and Wood-Based Materials*. ASTM International. West Conshohocken, Pennsylvania.
8. ASTM. 2010. Standard D2915. *Standard Practice for Sampling and Data Analysis for Structural Wood and Wood-Based Products*. ASTM International. West Conshohocken, Pennsylvania.
9. ASTM. 2012. Standard D3737. *Standard Practice for Establishing Allowable Properties for Structural Glued Laminated Timber (Glulam)*. ASTM International. West Conshohocken, Pennsylvania.
10. ASTM. 2007. Standard D4442. *Standard Test Methods for Direct Moisture Content Measurement of Wood and Wood-Base Materials*. ASTM International. West Conshohocken, Pennsylvania.
11. ASTM. 2013. Standard D4444. *Standard Test Method for Laboratory Standardization and Calibration of Hand-Held Moisture Meters*. ASTM International. West Conshohocken, Pennsylvania.
12. ASTM. 2013. Standard D4761. *Standard Test Methods for Mechanical Properties of Lumber and Wood-Base Structural Material*. ASTM International. West Conshohocken, Pennsylvania.
13. ASTM. 2014. Standard D7341. *Standard Practice for Establishing Characteristic Values for Flexural Properties of Structural Glued Laminated Timber by Full Scale Testing*. ASTM International. West Conshohocken, Pennsylvania.
14. ASTM. 2012. Standard D7469. *Standard Test Methods for End Joints in Structural Wood Products*. ASTM International. West Conshohocken, Pennsylvania.
15. AWC. 2015. *National Design Specification for Wood Construction*. American Wood Council. Leesburg, Virginia.

Add a new non-mandatory Appendix X1 as follows:

APPENDIX X1. HISTORY OF STANDARD (NON-MANDATORY)

In July 2019, the APA Standards Committee on ANSI 117, *Standard Specification for Structural Glued Laminated Timber of Softwood Species*, was formed to revise the national standard under the consensus processes accredited by the American National Standards Institute (ANSI). This national standard, designated as ANSI 117-2020, supersedes ANSI 117-2015 with editorial changes in the standard format, update of referenced standards, and modification of 24F-1.8E stress class.

The names of the ANSI 117 Committee members when this version of the standard is published are as shown below.

<u>Name</u>	<u>Affiliation</u>	<u>Note</u>
<u>Deepareddy Akula</u>	<u>Stella-Jones (Formerly McFarland Cascade)</u>	
<u>Linda Brown</u>	<u>Southern Pine Inspection Bureau</u>	
<u>David Catta</u>	<u>IB X-LAM USA</u>	
<u>Kevin Cheung</u>	<u>Western Wood Products Association</u>	
<u>Mark Clark</u>	<u>Hexion Inc.</u>	<u>ExSub Member</u>
<u>Don DeVisser</u>	<u>Pacific Lumber Inspection Bureau</u>	<u>Vice Chair</u>
<u>Brad Douglas</u>	<u>American Wood Council</u>	
<u>Julie Frappier</u>	<u>Nordic Structures</u>	
<u>Bill Gareis</u>	<u>Ashland Chemical</u>	
<u>Bill Gould</u>	<u>ICC-ES</u>	
<u>Bill Grigsby</u>	<u>Trennah Detailing, LLC</u>	
<u>Levi Huffman</u>	<u>DR Johnson Wood Innovations</u>	
<u>Jessica Jennings</u>	<u>Georgia-Pacific Chemicals, LLC.</u>	
<u>Jeff Morrison</u>	<u>Rosboro LLC</u>	<u>Chair</u>
<u>Victor Pearson</u>	<u>American Laminators</u>	
<u>Douglas Rammer</u>	<u>USDA Forest Products Laboratory</u>	
<u>Andreas Rhude</u>	<u>Sentinel Structures, Inc.</u>	
<u>Glen Robak</u>	<u>Weyerhaeuser Company</u>	
<u>Scott Skinner</u>	<u>Akzo Nobel Coatings, Inc.</u>	
<u>Kurt Stochlia</u>	<u>KSPE Inc.</u>	
<u>Robert Taylor</u>	<u>Boise Cascade</u>	
<u>Leif Van Cott</u>	<u>UNALAM</u>	
<u>Jim Vogt</u>	<u>Structural Building Components Association</u>	
<u>Chris Whelan</u>	<u>Henkel Corporation</u>	
<u>Tom Williamson</u>	<u>T. Williamson – Timber Engineering, LLC</u>	<u>ExSub Member</u>
<u>Clay Winje</u>	<u>Kalesnikoff Lumber</u>	
<u>B.J. Yeh</u>	<u>APA - The Engineered Wood Association</u>	<u>Secretariat</u>
<u>Larry Zhou</u>	<u>Universal Timber Structures</u>	

Inquiries or suggestions for improvement of this standard should be directed to:

Secretariat, ANSI 117

APA – The Engineered Wood Association

7011 South 19th Street

Tacoma, WA 98466

Internet address: www.apawood.org

e-mail address: help@apawood.org