

Nail Withdrawal and Pull-Through Strength of Structural-Use Panels

Benjamin Herzog
Staff Scientist, Technical Services Division
APA – The Engineered Wood Association
Tacoma, Washington, U.S.A.

Borjen Yeh, Ph.D., P.E.
Director, Technical Services Division
APA – The Engineered Wood Association
Tacoma, Washington, U.S.A.

Summary

An extensive test program was conducted to develop nail withdrawal design values for wood structural panels. Tested variables included: nail type (plain shank vs. deformed shank), panel type (plywood vs. OSB) and thickness and exposure condition. Testing followed the procedures described in ASTM D1761. Based on the test results, the recommended allowable nail withdrawal strength for plywood and OSB panels, expressed as an equivalent specific gravity, is 0.40 for plain or screw shank nails and 0.70 for ring shank nails. A wet-use adjustment factor of 0.75 is recommended for applications subject to wet-service conditions. In a separate study, the nailhead pull-through strength of wood structural panels was evaluated. While nailhead pull-through strength might not be considered in most designs, the results presented here can be used as a reference in evaluating nailhead pull-through performance of wood structural panels.

1. Introduction

A nailed sheathing-to-lumber joint may fail in one of two possible modes when subjected to a load applied along the axis of the fastener: shank withdrawal from the lumber and nailhead pull-through of the sheathing material. Under certain circumstances, such as strong gusts of wind, hurricanes or seismic activity, shingles or siding may be loosened or detached as nails are withdrawn. Alternatively, these lifting forces may pull roof or wall panels through nailheads. In either circumstance, the integrity of the structure may be severely impacted.

APA – The Engineered Wood Association has conducted more than 1,900 tests on wood structural panels (plywood and OSB) of different thicknesses using three different types of nails under three different exposure conditions to investigate the affect of these variables on nail withdrawal strength. This paper presents the background information and test data used to develop the APA-recommended nail withdrawal design values for wood structural panels. In addition, the results of a study, whereby the nailhead pull-through strengths of wood structural panels were evaluated under two different exposure conditions, are reported.

2. Nail Withdrawal Strength of Plywood and OSB

2.1 Objectives

It is well known that the resistance of a nail shank to direct withdrawal from wood-based materials is a function of several factors, including material density, nail diameter, and depth of penetration (FPL, 1999). In order to develop nail withdrawal design values for wood structural panels, other factors such as nail type (plain shank vs. deformed shank), exposure condition, and the vertical density profile of the tested structural panel should be considered. The objective of this study was to investigate the effect of these variables and to develop nail withdrawal design values for wood structural panels.

2.2 Materials and Methods

2.2.1 Materials

A total of 8 plywood panel types and 8 OSB panel types were used in the testing. A complete description of the panel materials is presented in Table 1.

The withdrawal testing was conducted using one of three nail types: *Plain shank* = 2.5 mm x 57 mm (Senco Product BJ23E), *Ring shank* = 2.5 mm x 57 mm (Senco Product BJ23), and *Screw shank* = 2.5 mm x 57 mm (Senco Product BF23).

2.2.2 Methods

Nail withdrawal tests were conducted following the procedures described in ASTM D1761, *Standard Test Method for Mechanical Fasteners in Wood* (ASTM, 2005a).

Test specimens, measuring 127 mm x 152 mm, were tested under three moisture conditions, as described in Table 2. *Dry-dry* specimens were intended to simulate ideal field construction practice whereby panels are installed under dry conditions and protected by siding or shingles before being

Table 1. Panel materials used in nail withdrawal testing

	Nominal thickness, mm (in.)	Species	Specific Gravity ^a
Plywood	9.5 (3/8)	hemlock, Group 2 fir or better	0.51
	9.5 (3/8)	southern pine	0.53
	15 (19/32)	southern pine	0.53
	15 (19/32)	Douglas-fir, larch	0.50
	16 (5/8)	radiata pine, Douglas-fir	0.50
	18 (23/32)	southern pine	0.54
	18 (23/32)''	Douglas-fir, larch	0.40
	28.5 (1 1/8)	lodgepole pine, white fir, Douglas-fir	0.43
OSB	9.5 (3/8)	southern pine	0.66
	9.5 (3/8)	aspen, pine, birch	0.63
	15 (19/32)	aspen	0.58
	15 (19/32)	aspen, cottonwood	0.59
	15 (19/32)	southern pine	0.63
	18 (23/32)	southern pine & hardwoods	0.62
	18 (23/32)	Aspen	0.54
	28.5 (1 1/8)	aspen, birch, balsam poplar	0.58

^a Based on oven-dry weight and as-received volume.

Table 2. Tested moisture conditions

Condition	Insertion	Withdrawal	Coded as
1	Dry	Dry	Dry-Dry
2	Dry	Wet-Redry ^a	Dry-Wet-Dry
3	Wet ^b	Wet-Redry	Wet-Wet-Dry

^a After 24-hour water soak and redried to approximately equilibrium MC (6-10%).

^b Specimens were soaked for 24 hours before nail insertion.

exposed to excessive moisture. In this work, these specimens were equilibrated at standard conditions ($20 \pm 3^\circ \text{C}$ and $65 \pm 3\% \text{RH}$) prior to testing.

Specimens coded as *Dry-Wet-Dry* were intended to simulate panels installed under dry conditions, but then exposed to heavy rain or excessive moisture due to delay in siding and/or shingle installation. Panels under these conditions would dry slowly to EMC. Therefore in this study, after being soaked for 24 hours, specimens were subjected to standard conditions until equilibrated prior to testing.

The exposure condition *Wet-Wet-Dry* was intended to simulate panels that had been allowed to get wet prior to installation. For these specimens, nails were inserted after the panels were soaked for 24 hours. As with the *Dry-Wet-Dry* specimens, panels under these conditions would dry slowly to EMC. Therefore, specimens were subjected to standard conditions until reaching equilibrium prior to testing.

Nails were manually hammered into the specimens with the nail shank as close to 90 degrees with the surface of specimen as possible. A nail tip penetration of about 9.5 mm was maintained. The rate of withdrawal was set at 2.5 mm/min. The test setup is illustrated in Figure 1.

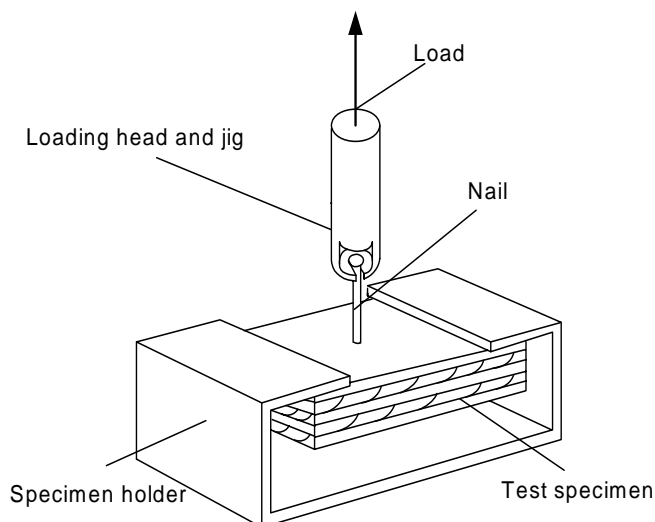

Figure 1. Nail withdrawal test setup

core. This suggests that overall density (or specific gravity) alone may not be a good predictor of the withdrawal strength of materials having a non-uniform vertical density profile.

2.3 Test Results

Results of the withdrawal testing are presented in Table 3. Withdrawal strength is reported in this paper and is calculated by dividing the tested capacity by the panel thickness.

2.3.1 Dry-Dry Exposure Condition

On average, plywood generally had a higher nail withdrawal strength in the dry-dry condition than OSB of the same thickness for all three types of nail shanks, even though OSB specimens had a higher specific gravity than the plywood specimens (Figure 2). The reason for this may be attributed to the density profile of the OSB, which characteristically has high-density faces, but a lower density

Table 3. Results of withdrawal tests

Panel type and thickness	Nail type	Dry-Dry			Dry-Wet-Dry			Wet-Wet-Dry		
		n	Withdrawal strength (N/cm)	COV %	n	Withdrawal strength (N/cm)	COV %	n	Withdrawal strength (N/cm)	COV %
9.5 mm Ply	Plain	60	117	29.0	---	---	---	40	68	36.4
	Ring	40	531	25.2	---	---	---	40	432	19.9
	Screw	---	---	---	---	---	---	40	185	32.7
9.5 mm OSB	Plain	80	131	41.0	---	---	---	40	137	39.7
	Ring	40	489	27.4	---	---	---	40	423	21.2
	Screw	---	---	---	---	---	---	40	142	44.3
15 mm Ply	Plain	40	189	28.5	---	---	---	---	---	---
	Ring	---	---	---	---	---	---	---	---	---
	Screw	---	---	---	---	---	---	---	---	---
16 mm Ply	Plain	40	140	20.7	40	118	16.9	40	159	29.6
	Ring	40	554	20.3	40	471	17.5	40	517	9.7
	Screw	40	147	24.3	40	271	24.3	40	411	27.1
15 mm OSB	Plain	79	132	29.3	40	203	24.0	40	177	27.6
	Ring	40	493	21.9	40	374	15.2	40	423	20.9
	Screw	40	112	37.3	40	242	21.2	40	233	31.6
18 mm Ply	Plain	40	151	46.7	---	---	---	---	---	---
	Ring	---	---	---	---	---	---	---	---	---
	Screw	---	---	---	---	---	---	---	---	---
18 mm OSB	Plain	40	128	28.9	---	---	---	---	---	---
	Ring	---	---	---	---	---	---	---	---	---
	Screw	---	---	---	---	---	---	---	---	---
28.5 mm Ply	Plain	40	144	33.2	---	---	---	40	144	21.8
	Ring	40	476	12.7	---	---	---	40	399	14.2
	Screw	40	120	26.2	---	---	---	40	225	15.1
28.5 mm OSB	Plain	40	109	26.6	---	---	---	40	237	22.3
	Ring	40	474	16.0	---	---	---	40	300	20.6
	Screw	40	111	21.6	---	---	---	40	221	22.2

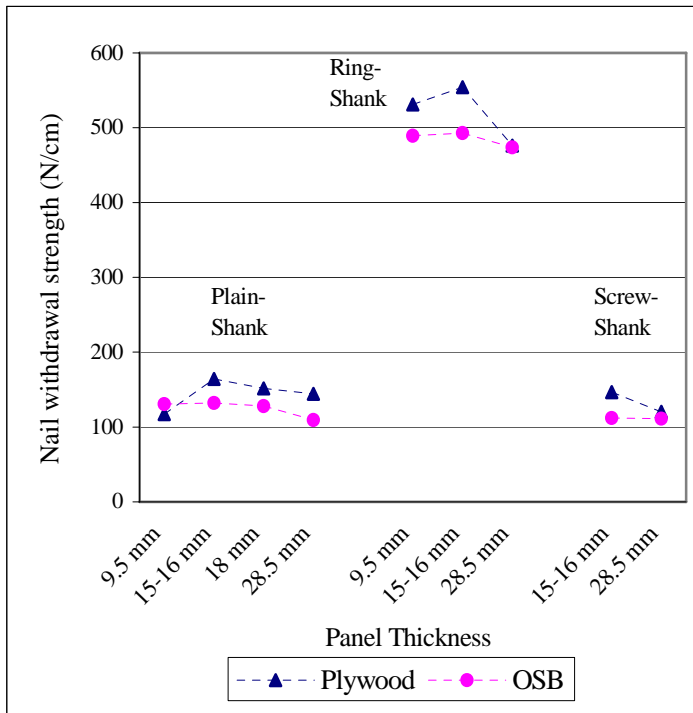

Figure 2. Average withdrawal strengths (Dry-Dry condition)

the screw shank nails. Ring shank nails have annularly threaded rings that serve as a mechanical lock prohibiting withdrawal. Therefore, in order to withdraw these nails, both friction and shear forces need to be overcome.

2.3.2 Dry-Wet-Dry Condition

The withdrawal strength for the plain shank nails under the Dry-Wet-Dry condition decreased for the 16 mm plywood but increased for the 15 mm OSB, compared to the respective Dry-Dry tests results. The withdrawal strengths of the ring shank nails under the Dry-Wet-Dry condition were all lower, for both the plywood and OSB, than the strengths under the Dry-Dry condition. Screw shank nails, however, obtained substantially higher withdrawal strengths under the Dry-Wet-Dry condition than those achieved under a Dry-Dry condition. The increased withdrawal strengths may be attributed to higher friction forces due to irreversible swelling of the panels as a result of the 24-hour water soak. The water soak may have also weakened the wood fibers, which would lower the shear strength of the wood thereby decreasing the withdrawal resistance advantage experienced with ring shank nails.

2.3.3 Wet-Wet-Dry Condition

With only one exception, e.g., 9.5mm plywood, the withdrawal strengths for plain shank nails under Wet-Wet-Dry conditions were higher compared to those under Dry-Dry conditions. Similarly, the screw shank nails had much higher withdrawal strengths under Wet-Wet-Dry conditions than that under Dry-Dry conditions. The Dry-Dry withdrawal strengths for the ring shank nails, however, outperformed the withdrawal strength under Wet-Wet-Dry conditions. The increased withdrawal strengths seen here for the plain shank and screw shank nails may be due to softening of the wood fibers as a result of the water soak. This, in turn, would result in less splitting (broken wood fiber) when the nail was driven. In addition, the shrinking of the panel during the re-equilibration was likely to enhance the frictional resistance of the nail.

The differences in withdrawal strength between the plain shank and screw shank nails for a specific panel type and thickness were small and statistically insignificant in most cases. Surface friction is the chief mechanism holding an embedded plain shank nail in a structural panel. Therefore, the greater the frictional surface, the higher the withdrawal strength. Surface friction is, in part, a function of the nail diameter and penetration (embedment). Screw shank nails typically have spiral helixes along its shank, however the total frictional surface of the screw shank did not seem to be much greater than plain shank nails of the same wire diameter. In addition, screw shank nails had a tendency to rotate during the testing which presumably led to lower strengths than if the nail was truly axially withdrawn.

The withdrawal strength of the ring shank nails was much higher than the plain and

2.4 Allowable Nail Withdrawal Strength (Dry Condition)

Based on the test results and a statistical data analysis, the following factors were considered in determining the allowable nail withdrawal strength:

1. While there may be a slight difference in the nail withdrawal strength of plywood and OSB at a particular panel thickness in dry-dry condition, the trend is inconclusive for other exposure conditions. This does not warrant a separate design value for each panel type.
2. The majority of the pairwise comparisons of ring shank nails showed no significant differences in withdrawal strength between different panel thicknesses and panel types.
3. The differences between the plain shank and screw shank nails of specimens of the same thickness were insignificant in most cases. Therefore, the allowable withdrawal strength for plain shank nails can be applied to screw shank nails.

The average and allowable nail withdrawal strengths are summarized in Table 4. The design values are also expressed as an equivalent specific gravity as compared to Table 11.2C of the National Design Specification for Wood Construction (ANSI/AF&PA, 2005) using a nail having a wire diameter of 2.5 mm (0.099 inch).

Table 4. Allowable nail withdrawal under Dry-Dry conditions

	Plain shank nail			Ring shank nail
	Plywood and OSB	Plywood	OSB	Plywood and OSB
Number of Tests	459	220	239	240
Mean, N/cm	136	146	127	503
Standard Deviation, N/cm	49	53	43	111
COV, %	36.2	37	34.1	22.0
Allowable Strength ^a , N/cm (lb/in.)	27 (16)	29.1 (17)	25 (15)	101 (57)
Equivalent Specific Gravity	0.42	0.43	0.41	0.70

^a Determined by dividing the average test value by a factor of five (5), which accounts for load duration, test conditions, and factor of safety.

Even though a significant number of nail withdrawal tests were conducted in this study, it is perceivable that some commodity panels may have different nail withdrawal strengths. To account for this likely variation, the lower confidence interval (LCI) on the mean nail withdrawal strength was used. The LCI is calculated in accordance with Equation 1.

$$LCI = \bar{X} - t_{(0.05, n-1)} \frac{s}{\sqrt{n}} \quad [1]$$

Where,

\bar{X} = sample mean

$t_{(0.05, n-1)}$ = t statistic based on $\alpha = 0.05$

s = sample standard deviation

n = sample size

For plain shank nails, since OSB is associated with a slightly lower mean withdrawal strength than plywood (see Table 4), the lower confidence interval was calculated based on the statistics from OSB only. The LCI and equivalent specific gravity for plain shank and ring shank nails are presented in Table 5. The resulting equivalent specific gravity is 0.40 and 0.70 for the plain shank and ring shank nails, respectively, based on the withdrawal strength at the lower 95% confidence interval.

Table 5. Equivalent specific gravity for the nail withdrawal strength based on LCI^a

Nail type	\bar{X}	s	n	t	LCL	LCI/5	EQSG
Plain shank	127	43	239	1.970	122	24	0.40
Ring shank	503	111	240	1.970	489	98	0.70

^a EQSG for plain shank nails is based on OSB data. EQSG for ring shank nails is based on plywood and OSB data.

2.5 Allowable Nail Withdrawal Strength Under Other Moisture Conditions

2.5.1 Allowable Nail Withdrawal Strength Under Dry-Wet-Dry Condition

The test data of the 16-mm plywood and 15-mm OSB under Dry-Wet-Dry condition are summarized in Table 6.

Table 6. Allowable nail withdrawal strength under Dry-Wet-Dry conditions

	16 mm plywood		15 mm OSB	
	Plain shank	Ring shank	Plain shank	Ring shank
Number of Tests	40	40	40	40
Mean, N/cm	118	471	203	374
COV, %	16.9	17.5	24.0	15.2
Allowable Strength, N/cm (lb/in.)	24 (13)	94 (54)	41 (23)	75 (43)
(Dry-Wet-Dry)/(Dry-Dry)	0.81	0.95	1.53	0.75

2.5.2 Allowable Nail Withdrawal Strength Under Wet-Wet-Dry Condition

The test data of specimens under the Wet-Wet-Dry condition are summarized in Table 7.

Table 7. Allowable nail withdrawal strength under Wet-Wet-Dry conditions

	Plain shank		Ring shank
	Plywood ^a	OSB ^b	Plywood & OSB ^c
Number of Tests	120	120	240
Mean, N/cm	124	184	416
COV, %	43.0	36.0	23.3
Allowable Strength ^d , N/cm (lb/in.)	25 (14)	37 (21)	83 (47)
(Wet-Wet/Redry)/(Dry-Dry)	0.93	1.40	0.82

^a 9.5 mm, 15 mm, 16 mm, 18 mm, and 28.5 mm plywood.

^b 9.5 mm, 15 mm, 18 mm, and 28.5 mm OSB.

^c Plywood and OSB of all thicknesses.

^d Mean divided by 5.

2.6 Recommended Allowable Nail Withdrawal Strength

Based on the test results, the allowable nail withdrawal strength for plywood and OSB panels, expressed as equivalent specific gravity, is given in Table 8. For simplicity, the most conservative strength ratio value of 0.75 obtained from Tables 6 and 7 is recommended as the adjustment factor for wet-use conditions.

Table 8. Equivalent specific gravity for the nail withdrawal strength of plywood and OSB^{a,b}

	Plain shank or screw shank nail	Ring shank nail
Equivalent Specific Gravity	0.40	0.70

^a Dry use application (moisture content less than 16%). A wet-use factor of 0.75 shall be applied to the equivalent specific gravity for applications subject to wet-service conditions.

^b Other adjustment factors given in 2005 NDS Tables 10.3.1 or 7.3.1 are applicable.

3. Nailhead Pull-Through Resistance of Plywood and OSB

3.1 Objectives

The resistance of nailhead pull-through is influenced by numerous factors, some of which include: nailhead diameter, and the thickness, density, or condition (dry or wet) of the material under

investigation. The purpose of this study was to examine the effect of these variables on the nailhead pull-through performance of plywood and OSB structural-use panels.

3.2 Materials and Methods

3.2.1 Materials

Two thicknesses of plywood (9.5 mm and 13 mm) and three thicknesses of OSB (9.5 mm, 11 mm, and 12 mm) were tested. The nails used were 8d box nails (3 mm x 63.5 mm with a head diameter of 7.5 mm).

3.2.2 Test Methods

Testing was conducted as per Sections 54-60 of ASTM D 1037, *Standard Test Methods for Evaluating Properties of Wood-Base Fiber and Particle Panel Materials* (ASTM, 2005b).

Panel specimens, measuring 127 mm by 152 mm, were tested under two moisture conditions: “Dry” and “Wet”. Dry specimens were equilibrated at standard conditions ($20 \pm 3^\circ \text{C}$ and $65 \pm 3\%$ RH) prior to testing. An 8d box nail, with dimensions as stated above, was driven into each test specimen so that the nailhead was flush with the specimen surface. The test apparatus shown in Figure 1 was modified for the nailhead pull-through testing. A load was applied to the test specimen by a uniform motion of the test machine at a rate 1.5 mm/min.

The wet condition was designed to simulate a worst-case scenario whereby panels are exposed to severe wetting after being installed. In this testing, nails were driven into the specimens prior to a 24-hour water soak. Specimens were tested immediately upon removal from the water.

3.3 Test Results

The nailhead pull-through test results are summarized in Table 9.

Table 9. Average values of nailhead pull-through tests^a

Panel Materials	Species	Exposure Condition	Pull-through (N)	Ratio of Mean Capacity Wet/Dry	Allowable pull-through ^d (N)	Density ^e (g/cm ³)
9.5 mm (3/8") Plywood	Hemlock, Group 2 or better	Dry	1,351 (20.3) ^c	0.68	172	0.53 (4.9) ^c
		Wet	926 (23.0)			0.49 (3.6)
9.5 mm (3/8") OSB	Aspen, pine, birch	Dry	1,351 (27.1)	0.88	215	0.64 (5.3)
		Wet ^a	1,186 (28.9)			0.67 (4.4)
11 mm (7/16") OSB	80% aspen, 20% cottonwood	Dry	1,568 (19.3)	0.70	227	0.60 (3.9)
		Wet ^a	1,245 (27.9)			0.60 (4.4)
12 mm (15/32") OSB	Aspen	Dry	1,749 (17.6)	0.91	291	0.61 (5.8)
		Wet ^a	1,549 (18.5)			0.63 (6.9)
13 mm (1/2") Plywood	Southern pine ^b	Dry	1,908 (11.7)	0.86	313	0.57 (2.2)
		Wet ^a	1,646 (15.1)			0.57 (2.7)

^a Each value is an average for 40 tests with 8d box nails (3 mm x 63.5 mm with a head diameter of 7.5 mm).

^b Exact source unknown.

^c Numbers in parentheses represent coefficient of variation (%).

^d Calculated in accordance with Equation 1 based on the results in wet condition and divided by 5.

^e Based on as-received weight and volume.

A reduction in nailhead pull-through resistance was noted for all specimens tested at the wet condition. The wet-to-dry ratios of the mean test capacities ranged from 0.68 (9.5 mm plywood) to 0.91 (12 mm OSB). For estimating the allowable pull-through capacity of the structural panels, the lower confidence interval on the mean test value could be calculated in accordance with Equation 1. The allowable nailhead pull-through capacity of structural panels of a specific thickness may be conservatively estimated using the lower confidence interval in wet condition divided by 5, as also shown in Table 9.

The results suggest that panel density does not affect the nailhead pull-through strength in a systematic way (Figure 3). As discussed in the withdrawal strength, the non-uniform vertical density profile of OSB may complicate predictions of pull-through resistance based on overall panel density. Conversely, a linear relationship between panel thickness and pull-through capacity is apparent, as shown in Figure 4.

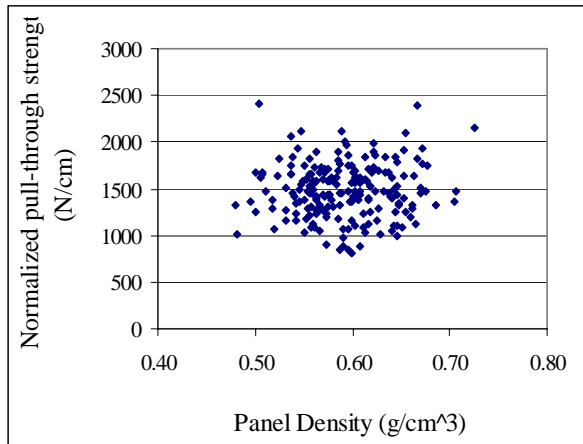

Figure 3. Nailhead pull-through strength by panel density (dry condition)

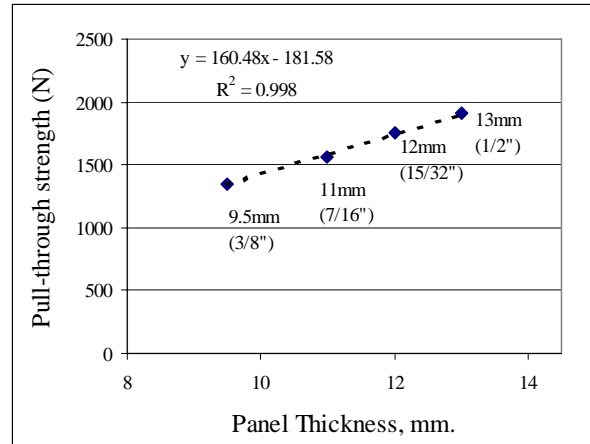

Figure 4. Nailhead pull-through capacity by panel thickness (dry condition)

4. Conclusions

For the allowable nail withdrawal resistance of plywood or OSB panels, *APA – The Engineered Wood Association* recommends that an equivalent specific gravity of 0.40 (see 2005 NDS Table 11.2C) be used for both plain shank and screw shank nails. An equivalent specific gravity of 0.70 is recommended for ring shank nails (see Table 8). A wet-use factor of 0.75 is recommended when subject to wet-service conditions.

The nailhead pull-through strength for 8d box nails, as presented in Table 9, can be used as a reference for evaluating nailhead pull-through performance of structural panels.

5. References

- [1] FPL. 1999. *Wood handbook—Wood as an engineering material. Gen. Tech. Rep. FPL-GTR-113*. Madison, WI, Department of Agriculture, Forest Service, Forest Products Laboratory, 463 pp.
- [2] ASTM. 2005a. *Standard Test Method for Mechanical Fasteners in Wood. D1761-88*. American Society for Testing and Materials, West Conshohocken, PA, 13 pp.
- [2] AF&PA. 2005. *National Design Specification for Wood Constructions*, American Forest & Paper Association, Washington, D.C., 174 pp.
- [3] ASTM. 2005b. *Standard Test Method for Evaluating Properties of Wood-base Fiber and Particle Panel Materials. D1037-96a*. American Society for Testing and Materials, West Conshohocken, PA, 31 pp.