



APA Report T2008P-77

Standardization Testing of Structural Insulated Panels (SIP) – BASF Polyurethane

©2008 APA - The Engineered Wood Association

***by Edward L. Keith, P.E.
Technical Services Division
August 30, 2008***



INTERNATIONAL
ACCREDITATION SERVICE, INC.
Leading Accreditors Since 1975

TL-215

REPRESENTING THE ENGINEERED WOOD INDUSTRY

7011 South 19th Street • Tacoma, Washington 98466-5333 • Phone: (253) 565-6600 • Fax: (253) 565-7265 • www.apawood.org

Standardization Testing of Structural Insulated Panels (SIP) – BASF Polyurethane

SUMMARY

APA – The Engineered Wood Association worked with the Structural Insulated Panel Association (SIPA) and the wood structural panel industry in the development of minimum design properties for the wood structural panel skins. Minimums were also established for adhesives and foam density. Using these industry-developed minimum properties for panels, adhesives and foam density, APA ran a series of tests on SIPs manufactured to reflect these minimums with an expanded polystyrene foam core. Tests included shear, axial, transverse, and SIPS lintel testing and results are published in APA Report No. T2006P-33 and formed the basis for a series of prescriptive use requirements for a code change proposal for the International Residential Code.

At the request of Ainsworth Engineered, (USA) LLC, Cook, Minnesota a similar series of tests was conducted on SIPs manufactured with BASF foamed-in-place polyurethane insulation. This testing was conducted to determine the design values appropriate for the SIPs manufactured with the polyurethane foam. Preliminary testing was conducted on panels manufactured with urethane foam cores with a density of 2.0 lb/cu ft. This testing is reported in APA Report T2007P-40. Additional transverse load testing on panels manufactured at the Ainsworth Engineered, (USA) LLC, Bemidji, Minnesota plant with a foam core density of 2.2 lb/cu ft was conducted. The results of this testing is presented in this report.

Reported by:

Reviewed by:

EDWARD L. KEITH, P.E.
Manager, Codes and Engineering
Technical Services Division

THOMAS D. SKAGGS, Ph.D., P.E.
Manager, Product Evaluation
Technical Services Division

This report shall not be reproduced except in full and only with the written approval of *APA - The Engineered Wood Association* laboratory management.

Accredited by



LABORATORY ACCREDITATIONS AND LISTINGS HELD BY APA

APA – *The Engineered Wood Association* is committed to providing its clients with high-quality service and information through documented test procedures and thorough, accurate collection of data. As a part of that commitment, a Quality Program has been established by APA based on the international document ISO/IEC Guide 17025: *General Requirements for the Competence of Testing and Calibration Laboratories*. The APA Quality Program follows the Accreditation Criteria and Requirements for Testing Organizations (CAN-P-4) and National Accreditation Program for Testing Organizations, Standards Council of Canada (SCC). APA is accredited or listed as a testing laboratory for specific scopes by the following agencies (certification agency accreditations also shown where applicable):

- Standards Council of Canada (SCC), as an accredited Testing Organization (No. 89)
- Standards Council of Canada (SCC), as an accredited Certification Body
- International Accreditation Service (IAS), as an accredited Testing Laboratory (TL-215)
- International Accreditation Service (IAS), as an accredited Inspection Agency (AA-649)
- Japanese Ministry of Agriculture, Forestry, and Fisheries (MAFF), as a Registered Foreign Certification Organization (RFCO), Notification No. 414: May 10, 2002
- City of Los Angeles, as a Compliance Assurance and Testing Agency (No. 22192)
- Miami-Dade County, as a Testing Laboratory (Certification No. 00-1114.02)
- The Florida Department of Committee Affairs, as a Product Testing Laboratory (TST2513)
- The Florida Department of Committee Affairs, as a Product Quality Assurance Entity (QUA2521)
- The Florida Department of Committee Affairs, as a Product Validation Entity (VAL3120)

This report contains data generated through testing of engineered wood products according to various test methods. Many accepted test methods conducted by APA are accredited or listed by organizations listed above. A list of methods is available upon request. Any test data in this report that is derived from test methods, which deviate from accepted procedure are noted. Accreditation or listing does not constitute endorsement of this report by the accrediting or listing agency or government.

The precision and bias of the test methods given in this report are being established.

Table of Contents

1. INTRODUCTION.....	4
2. MATERIAL DESCRIPTION.....	4
2.1 SIPS Panel Construction	4
2.1.1 Core	4
2.1.2 Facing	4
2.1.3 Adhesive	5
2.1.4 Specimen assembly.....	5
2.1.5 Fasteners.....	5
2.1.6 Lumber.....	5
3. TEST METHODS AND TEST ASSEMBLY DESCRIPTIONS.....	5
3.1 Racking Shear Test.....	5
3.2 Axial Load (Compressive) Tests.....	5
3.3 Transverse Load Tests.....	5
3.3.1 Test Specimen	5
3.3.2 Test Specimen Preparation	6
3.3.3 Test Method.....	6
3.4 SIP Lintel Test	6
4. RESULTS AND DISCUSSION	6
4.1 Racking Shear Test Results	6
4.2 Axial Load Test.....	6
4.3 Transverse Load Test.....	6
4.4 Lintel Test.....	7
5. CONCLUSION	7
5.1 Racking Shear Design Values.....	8
5.2 Axial Load (Compressive) Design Values	8
5.3 Transverse Load Design Values	8
5.4 SIP Lintel Design Values	8
5.5 Characteristic Properties	9
6. REFERENCES.....	10
7. APPENDICES.....	11

1. INTRODUCTION

In 2003 the Structural Insulated Panel Association (SIPA) made a proposal to the U. S. Department of Housing and Urban Development (HUD), through their Partnership for Advancing Technology in Housing (PATH), to develop a prescriptive method for the residential design using structural insulated panels (SIPs). HUD approved the proposal and subsequently signed a contract with the National Association of Home Builders – Research Center (NAHB-RC) to manage the project. The NAHB-RC has worked in conjunction with Building Works, Incorporated, to develop this method. The result of this effort was the development of a prescriptive procedure for adoption by the International Residential Code (IRC).

APA – The Engineered Wood Association worked with SIPA and the wood structural panel industry in the development of minimum design properties for the wood structural panel skins. Minimums were also established for adhesives and foam density. Using these industry-developed minimum properties for panels, adhesives and foam density, APA ran a series of tests on SIPs manufactured to reflect these minimums with an expanded polystyrene foam core. Tests included shear, axial, transverse, and SIPs lintel testing and results are published in APA Report No. T2006P-33. These tests were all conducted in accordance with recognized test methods (ASTM D4761, and E72). From the results of these tests, capacities were developed (Tables 4-7) and ultimately used to develop prescriptive use requirements for a code change proposal for the International Residential Code.

At the request of Ainsworth Engineered, (USA) LLC, Cook, a similar series of tests was conducted on SIPs manufactured with BASF foamed-in-place polyurethane insulation. This testing was conducted to determine the design values appropriate for the SIPs manufactured with the polyurethane foam. Preliminary testing was conducted on panels manufactured with urethane foam cores with a density of 2.0 lb/cu ft. This testing is reported in APA Report T2007P-40. Additional transverse load testing on panels manufactured at the Ainsworth Engineered, (USA) LLC, and Bemidji, Minnesota plant with a foam core density of 2.2 lb/cu ft was conducted. The results of this testing is presented in this report.

2. MATERIAL DESCRIPTION

2.1 SIPS Panel Construction

SIP test specimens were manufactured as follows:

2.1.1 Core

The core material of SIPs, for the tests covered by this test report, was composed of foamed-in-place polyurethane foam insulation. The reported minimum density was 2.2 lb/cu ft. The minimum thickness of the core for SIP panels was 3.5 inches (89 mm).

2.1.2 Facing

Facing materials for the structural insulated panels were oriented strand board panels (OSB) each having a minimum nominal thickness of 7/16 inches (11 mm) and conforming to DOC PS 2 except that the minimum property standards were selected to form an agreed-upon baseline for prescriptive provisions. All panels meet the requirements of APA N610 and, for the purpose of

the transverse load test, the panels were produced by Ainsworth at their Bemidji facility (Mill 353).

2.1.3 Adhesive

The panels were fabricated with a polyurethane foamed-in-place system that does not require an adhesive. The urethane bonds to the facings during the foaming process.

2.1.4 Specimen assembly

All SIP specimens were fabricated at Better Building Products, LLC, 209 Long Meadow Drive, Salisbury, NC, 28147 on July 15, 2008.

2.1.5 Fasteners

Fasteners used to connect the SIP facing panels to framing were 8d common nails (0.131x2-1/2-inch) conforming to ASTM F1667.

2.1.6 Lumber

Lumber used for assembly of test specimen was spruce-pine-fir #2 or better.

3. TEST METHODS AND TEST ASSEMBLY DESCRIPTIONS

3.1 Racking Shear Test

Tests were conducted to develop racking shear design properties for prescriptive SIP panels as proposed for the IRC and were previously reported in APA Report T2007P-40.)

3.2 Axial Load (Compressive) Tests

Tests were conducted to develop axial load (compressive) design properties for prescriptive SIP panels as proposed for the IRC and were previously reported in APA Report T2007P-40.)

3.3 Transverse Load Tests

Tests were conducted to develop transverse load (load perpendicular to the plane) design properties for prescriptive SIP panels as proposed for the IRC. (The SIPs panels with a 5-1/2 inch core were previously reported in APA Report T2007P-40.)

3.3.1 Test Specimen

Test specimens were fabricated from SIP panels as described below:

Table 3. Transverse Load Specimen

SIP Specimen Size Thickness (in.) x Height (ft) x Width (ft)	Number Each (Test/Spare)
3-1/2 x 4 x 8	3/1
3-1/2 x 4 x 10	3/1

3.3.2 Test Specimen Preparation

Test specimens were fabricated from the SIP panel sizes listed in Table 3 and prepared in accordance with Figure A1. All outside ends and edges were routed out at the factory to 1-1/2 inch. Along the four-foot panel ends a 2-foot spruce-pine-fir 2x member sized to match the foam thickness were placed within this routed area and were attached to both OSB skins with 8d common (2-1/2x0.131 inch) nails placed at 6 inches on center.

3.3.3 Test Method

The transverse load specimens were tested in accordance with ASTM E72-05, Section 11 and Figure B1. Route-outs for electrical junction boxes were placed on the compression side of the SIP.

3.4 SIP Lintel Test

Tests were conducted to develop prescriptive capacities for nominal 12 inches deep SIPS lintels as proposed for IRC in various lengths. Strength and stiffness characteristics were developed for the tested specimens. This testing was previously reported in APA Report T2007P-40.)

4. RESULTS AND DISCUSSION

4.1 Racking Shear Test Results

The results of the racking shear tests were previously reported in APA Report T2007P-40.)

4.2 Axial Load Test

The results of the axial load tests were previously reported in APA Report T2007P-40.)

4.3 Transverse Load Test

The results of the transverse load test are shown below: The results of the SIPs panels with 5-1/2 inch core were previously reported in APA Report T2007P-40. Pictures of tests in progress and typical shear failure of specimen cores are shown in Figures C1 – C3.

Table 4. Transverse load test results for 8 foot SIP panels with 3-1/2 inch core

Wall	Height (inches)	Ultimate load (lbf)	Load at Strength Limit state (lbf/ft ²)	Slope (lbf/inches /4 feet)	Load at deflection (lbf)		
					L/240	L/180	L/120
1	96	5,890	184	3,194	1,280	1,708	2,551
2	96	5,958	186	3,242	1,443	1,874	2,719
3	96	6,218	194	3,273	1,306	1,758	2,612
Mean		6,022	188	3,236	1,343	1,780	2,627
Calculated allowable load (lbf/ft ²)		63	--	--	42	56	82
Allowable load ^(c) (lbf/ft ²)		--	--	--	42	56	63

^(a) Calculated allowable load (lbf/ft²) is based on the mean ultimate load (lbf) divided by the total SIP panel area (ft²) and by a factor of 3.0.

^(b) Allowable load (lbf/ft²) is based on the mean load (lbf) at a specific deflection limit and by the total SIP panel area (ft²).

^(c) Allowable load (lbf/ft²) is tabulated based on the calculated ultimate load or the calculated load at a specific deflection limit, whichever is less.

Table 5. Transverse load test results for 10 foot SIP panels with 3-1/2 inch core

Wall	Height (inches)	Ultimate load (lbf)	Load at Strength Limit state (lbf/ft ²)	Slope (lbf/inches /4 ft)	Load at deflection (lbf)		
					L/240	L/180	L/120
1	120	5,764	144	2,142	1,227	1,590	5,764
2	120	5,485	137	2,128	1,099	1,449	2,008
3	120	4,989	125	2,229	1,087	1,470	2,197
Mean		5,413	135	2,166	1,138	1,503	3,323
Calculated allowable load (lbf/ft ²)		45	--	--	28	38	83
Allowable load ^(c) (lbf/ft ²)		--	--	--	28	38	45

^(a) Calculated allowable load (lbf/ft²) is based on the mean ultimate load (lbf) divided by the total SIP panel area (ft²) and by a factor of 3.0.

^(b) Allowable load (lbf/ft²) is based on the mean load (lbf) at a specific deflection limit and by the total SIP panel area (ft²).

^(c) Allowable load (lbf/ft²) is tabulated based on the calculated ultimate load or the calculated load at a specific deflection limit, whichever is less.

4.4 Lintel Test

The results of the SIP lintel tests were previously reported in APA Report T2007P-40.)

5. CONCLUSION

From the test results shown in Section 4, the design values shown in Tables 6 through 9 were developed. These design values include the results from testing previously reported in APA Report T2007P-40. In addition, characteristic test values were developed and shown in Table

10. This table also includes the results from testing previously reported in APA Report T2007P-40. The design values in Tables 6 through 9 below are greater than or equal to those in APA Report No. T2006P-33 for the original SIPs panels fabricated with an expanded polystyrene core that formed the basis for the code change proposal to add SIPs prescriptive requirements to the body of the IRC. Based on this testing it can be seen that the prescriptive provisions of the 2007 Supplement to the 2006 International Residential Code in Section R614 are equally applicable to the SIPs panels fabricated in accordance with Section 2 of this report.

5.1 Racking Shear Design Values

Table 6. Racking shear design values for SIP wall panels

SIP Panel	Racking Shear Design Values (lbf/ft)
8 x 3-1/2	360
10 x 3-1/2	370
8 x 5-1/2	400
10 x 5-1/2	370

5.2 Axial Load (Compressive) Design Values

Table 7. Axial load design values for the SIP wall panels

SIP Panel	Axial Load Design Value (lbf/ft)
8 x 3-1/2	3,360
10 x 3-1/2	3,320
8 x 5-1/2	3,370
10 x 5-1/2	3,730

5.3 Transverse Load Design Values

Table 8. Transverse load design values for SIP wall panels

SIP Panel	Height (inches)	Design loads for deflection limits (lbf/ft ²)		
		L/240	L/180	L/120
8' high x 3-1/2" core	96	42	56	63
10' high x 3-1/2" core	120	28	38	45
8' high x 5-1/2" core	96	58	74	74
10' high x 5-1/2" core	120	43	57	63

5.4 SIP Lintel Design Values

Table 9. Design values for SIP lintels^a

Lintel Span (ft)	Allowable Load (lbf/ft)
2	1,185
4	590
6	325
8	185

^(a) Normal duration of load with a deflection of L/360

5.5 Characteristic Properties

Table 10. Characteristic Properties for BASF SIPs Wall Panels

Properties	SIP Dimension	Characteristic Value ^(a)	
		Average Load at Strength Limit State	Average load at serviceability Limit State
Racking Resistance ^(b,c) (lbf/ft)	--	1,132	377
Axial Load Capacity ^(d) (lbf/ft)	8' height	10,340	3,445
	10' height	10,578	3,526
Transverse Load Capacity ^(e) (lbf/ft ²)	4-1/2" x 8'	188	42
	4-1/2" x 10'	135	28
	6-1/2" x 8'	224	58
	6-1/2" x 10'	203	43
Lintel Load Capacity ^(f) (lbf/ft)	2' span	1,855	1,185
	4' span	1,170	560
	6' span	490	325
	8' span	235	185

- (a) The tabulated values are test values, as defined in this standard, and not intended for design use. For allowable design values in the U.S., the design values may be based on the average load at the strength limit state divided by 3 or the average load at the serviceability limit state.
- (b) Based on 8d Common (0.131 x 2-1/2 inch) nails at 6" Oc. Other fasteners with approved equivalent performance may be used.
- (c) For both 4-1/2-inch- and 6-1/2-inch-thick SIPs. The serviceability limit state is based on the net lateral deflection of the wall of 1/8 inch.
- (d) For both 4-1/2-inch and 6-1/2-inch-thick SIPs. The serviceability limit state is based on the net axial deformation of the wall of 1/8 inch.
- (e) The serviceability limit state is based on the net transverse deflection of the wall $H/240$, where H is the wall depth in inches.
- (f) For lintel depths 12 inches and greater. The serviceability limit state is based on the net edgewise deflection of the wall of $L/360$, where L is the lintel span in inches.

6. REFERENCES

- APA- the Engineered Wood Association. 2006. APA Report No. T2006P-33 – Standardization Testing of Structural Insulated Panels (SIPs) for The Structural Insulated Panel Association, Gig Harbor, Washington.
- APA- the Engineered Wood Association. 2007. APA Report No. T2007P-40 – Standardization Testing of Structural Insulated Panels (SIPs) – BASF Polyurethane. Tacoma Washington.
- APA – The Engineered Wood Association. 2008. APA Product Report No. PR-N610 – Qualified OSB Facing Materials for Structural Insulated Panels. Tacoma, Washington.
- ASTM. 2005. *Standard Test Methods of Conducting Strength Tests of Panels for Building Construction*. ASTM E72-05. American Society of Testing and Materials. West Conshohocken, PA.
- ASTM. 2005. *Standard Test Methods for Mechanical Properties of Lumber and Wood-Based Structural Material*. ASTM D4761-05. American Society of Testing and Materials. West Conshohocken, PA.
- ASTM. 2005. *Standard Specification for Rigid, Cellular Polystyrene*. ASTM C578-05. American Society of Testing and Materials. West Conshohocken, PA.
- ASTM. 2004. *Standard Specification for Adhesives for Structural Laminated Wood Products for Use Under Exterior (Wet Use) Exposure Conditions* ASTM D2559. American Society of Testing and Materials. West Conshohocken, PA.
- ASTM. 2005. *Standard Test Method for Surface Burning Characteristics of Building Materials*. ASTM E84-05e1. American Society of Testing and Materials. West Conshohocken, PA.
- ASTM. 2003. *Standard Test Method for Determining Bending Yield Moment of Nails*. American Society of Testing and Materials. ASTM F1575-03. West Conshohocken, PA.
- IRC. 2006. *International Residential Building Code*. International Code Council. Falls Church, VA.
- IRC. 2007. 2007 Supplement to the 2006 *International Residential Building Code*. International Code Council. Falls Church, VA.
- Voluntary Product Standard. 2004 . *Performance Standard for Wood-Based Structural-Use Panels - PS2-04*. National Institute of Standards and Technology. Gaithersburg, MD.

7. APPENDICES

List of Appendices

Appendix A: Drawings of Test Specimens: 1 page
Appendix B: Drawings of Test Assemblies: 1 page
Appendix C: Pictures of Tests in Progress and Failure Modes: 3 pages

Appendix A: Drawings of Test Specimens (1 page)

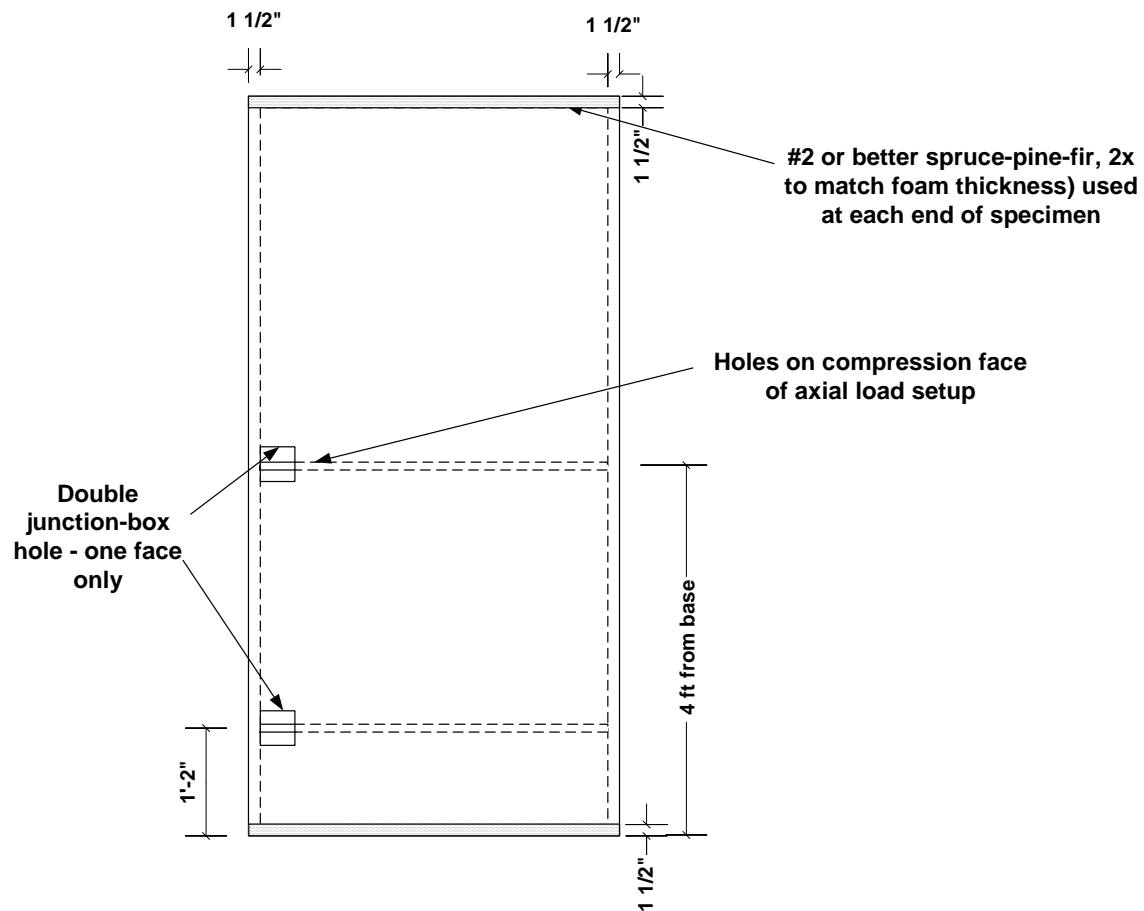

FIGURE A1. TRANSVERSE LOAD TEST SPECIMEN AND ASSEMBLY

Appendix B: Drawings of Test Assemblies (1 page)

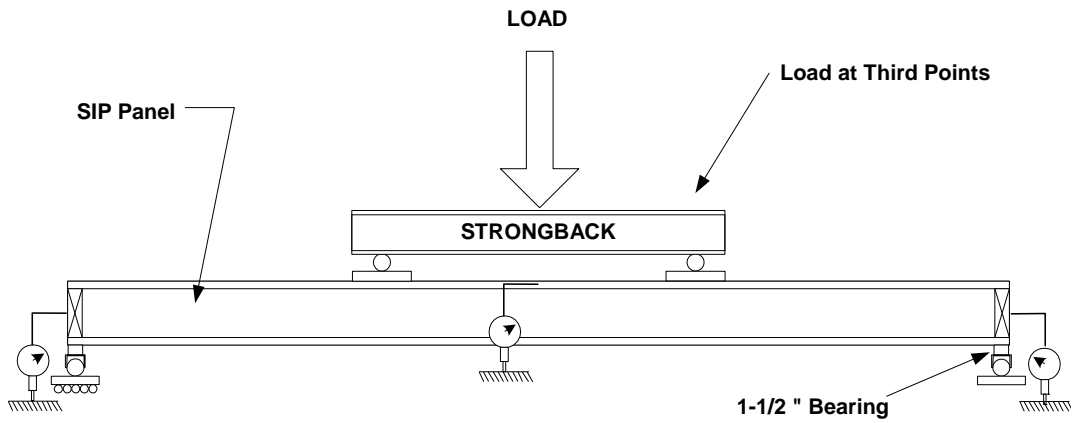

FIGURE B1. TRANSVERSE LOAD TEST ASSEMBLY

Appendix C: Pictures of Tests in Progress and Failure Modes (3 pages)



FIGURE C1. SIPS PANEL IN TRANSVERSE LOAD TEST APPARATUS – THIRD-POINT LOADING APPARATUS (File Picture)

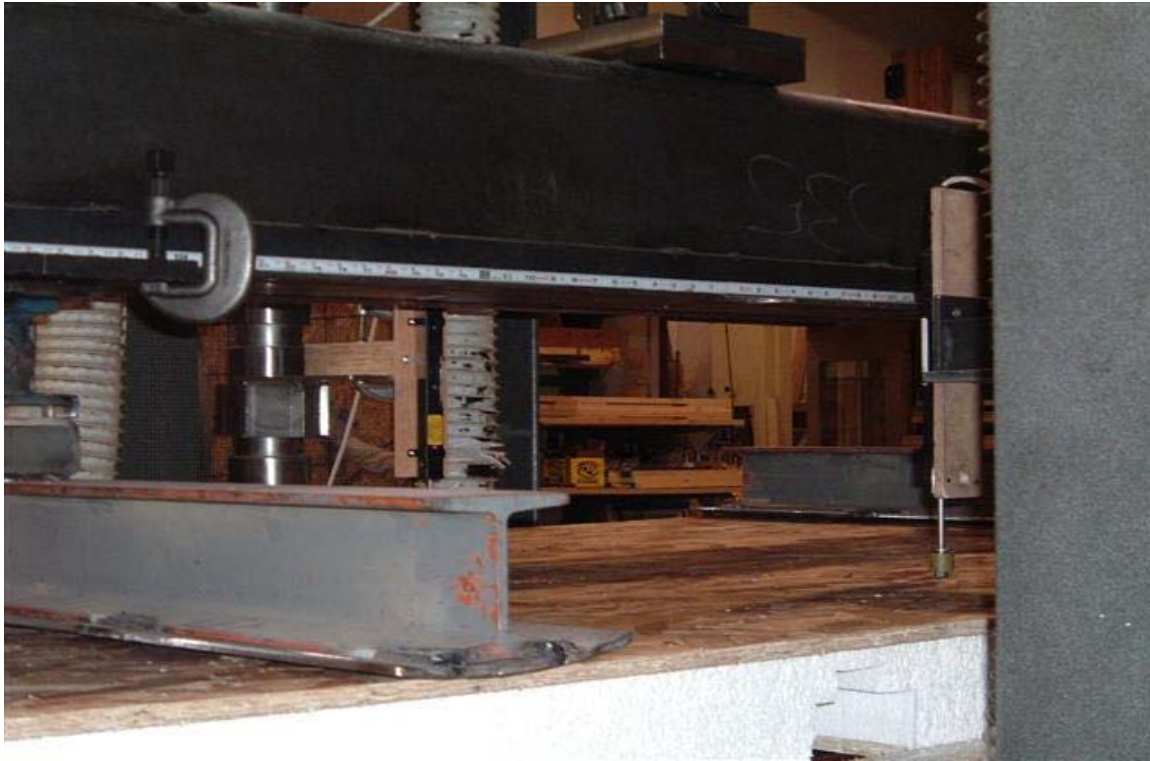

FIGURE C2. TRANSVERSE LOAD TEST ASSEMBLY – THIRD-POINT LOADING APPARATUS - WITH INSTRUMENTATION (file Picture)



FIGURE C3. TYPICAL SIPS TRANSVERSE LOAD FAILURE (Shear failure of core in vicinity of lower conduit chase)