



Fire-Rated Assemblies Tolko Industries Ltd.

PR-S356

Issued May 8, 2026

Products: Tolko T-TEC Series Prefabricated Wood I-Joists
Tolko Industries Ltd., P.O. Box 39, Vernon BC V1T 6M1, Canada
(250) 545-4411
www.tolko.com

1. Basis of the product report:
 - 2024 International Building Code (IBC): Sections 104.2.3 Alternative material, 703 Fire-Resistance Ratings and Fire Tests, 721 Prescriptive Fire Resistance, 722.6 Wood assemblies, and 2303.1.2 Prefabricated wood I-joists.
 - 2021, 2018, and 2015 IBC: Sections 104.11 Alternative materials, 703 Fire-Resistance Ratings and Fire Tests, 721 Prescriptive Fire Resistance, 722.6 Wood assemblies, and 2303.1.2 Prefabricated wood I-joists
 - 2024 International Residential Code (IRC): Sections R104.2.2 Alternative materials, R302.13 Fire protection of floors, and R502.1.2 and R802.1.7 Prefabricated wood I-joists.
 - 2021, 2018, and 2015 IRC: Sections R104.11 Alternative materials, R302.13 Fire protection of floors, and R502.1.2 and R802.1.8 (2021 and 2018 IRC only) Prefabricated wood I-joists
 - 2020 National Building Code of Canada (NBC): Clause 1.2.1.1 of Division A, Clauses 3.1.7, 4.1, 4.3.1.1, 9.10.3.1, 9.11, and 9.23.4.2 of Division B, Table 9.10.3.1.-B, and Appendix D
 - ASTM D5055-19e1, D5055-16, D5055-13e1, and D5055-13 recognized in the 2024 IBC and IRC, 2021 IBC and IRC, 2018 IBC and IRC, and 2015 IBC and IRC, respectively
 - American Wood Council Design for Code Acceptance DCA 3, Fire-Rated Wood-Frame Wall and Floor/Ceiling Assemblies
 - APA System Report SR-405
 - APA Product Reports PR-L356 and PR-L356(C)
 - ASTM E119 and CAN/ULC S101 full-scale fire test reports, and engineering analyses
2. Product description:

Tolko T-TEC Series I-joists covered in this report, as described in Table 1, are made with lumber flanges and oriented strand board (OSB) webs at the IB EWP Inc. facility in Pohénégamook, Quebec, under a private labelling agreement for Tolko Industries Ltd. in accordance with the in-plant manufacturing standard approved by APA.
3. Design properties:

Design properties for T-TEC Series I-joists are provided in APA PR-L356 in the U.S. and APA PR-L356(C) in Canada.
4. Product installation:

T-TEC Series I-joists covered in this report shall be installed in accordance with the recommendations provided by the manufacturer (<https://tolko.com/resources/>).
5. Fire-rated assemblies:

T-TEC Series I-joists have been shown through testing and engineering analysis to achieve the fire resistance ratings described in this report. Fire-rated assemblies for T-TEC Series I-joists shall be constructed in accordance with the prescriptive requirements provided in this report or recommended by the manufacturer (see link above). In addition, T-TEC Series I-joists shall be permitted for use in the fire-rated assemblies described in Section 4.2.2.2 (Assembly 2) of ICC-ES ESR-1405, and T-TEC Series I-joists with a minimum depth of 9-1/2 inches shall be permitted for use in the fire-rated assembly described in Sections 4.2.2.3 (Assembly 3) and 4.2.2.1 (Assembly 1) of ICC-ES ESR-1405, when installed in accordance with the requirements specified therein.

6. Fire-protection of floors:
T-TEC Series I-joists as described in Table 2, when installed and protected as specified in APA System Report SR-405 (www.apawood.org/resource-library), meet the requirements of 2024, 2021, 2018, and 2015 IRC Section R302.13, and are alternatives to the 2-by-10 dimension lumber prescribed in Exception 4 to 2024, 2021, 2018, and 2015 IRC Section R302.13 with demonstrated equivalent fire performance.
7. Limitations:
 - a) T-TEC Series I-joists covered in this report shall be designed in accordance with the code using the design properties specified in APA PR-L356 in the U.S. and APA PR-L356(C) in Canada.
 - b) T-TEC Series I-joists covered in this report are limited to dry service conditions where the average equilibrium moisture content of sawn lumber is less than 16% in the U.S. and the average equilibrium moisture content of solid-sawn lumber over a year is 15% or less and does not exceed 19% in Canada.
 - c) T-TEC Series I-joists covered in this report are permitted for use in fire-rated assemblies that meet the fire-resistance rating in accordance with the calculation method specified in NBC Appendix D-2.3.
 - d) T-TEC Series I-joists covered in this report are produced at IB EWP Inc. facility in Pohénégamook, Quebec, under a quality assurance program audited by APA.
 - e) This report is subject to re-examination in one year.
8. Identification:
T-TEC Series I-joists described in this report are identified by a label bearing the manufacturer's name (Tolko Industries Ltd.) and/or trademark, the APA assigned plant number (1135), the I-joist depth and series, the APA logo, the report number PR-L356, and a means of identifying the date of manufacture.

Table 1. Description of T-TEC Series I-Joists^(a)

Joist Series	Joist Depths (in.)	Flanges			Web	
		Material	Dimension		Material	Thickness (in.)
			Depth (in.)	Width (in.)		
TTI 400S	7-7/8 – 16	Proprietary SPF	1-1/2	2-1/2	OSB	3/8
TTI 600S	7-7/8 – 20	MSR	1-1/2	2-1/2	OSB	3/8
TTI 800S	7-7/8 – 20	MSR	1-1/2	3-1/2	OSB	3/8
TTI 900S	7-7/8 – 24	MSR	1-1/2	3-1/2	OSB	7/16

^(a) Referenced dimensions are nominal. Tolerances are as specified in the in-plant quality manual.

Table 2. Applicable T-TEC Series I-joists for SR-405 Assemblies

Assembly in SR-405	Applicable Joist Series ^(a)
FP-01	TTI 400S, TTI 600S, TTI 800S, TTI 900S
FP-02	TTI 400S, TTI 600S, TTI 800S, TTI 900S
FP-03	TTI 400S, TTI 600S, TTI 800S, TTI 900S
FP-04	TTI 400S, TTI 600S, TTI 800S, TTI 900S
FP-06	TTI 400S, TTI 600S, TTI 800S, TTI 900S
FP-07	TTI 400S, TTI 600S, TTI 800S, TTI 900S
FP-09	TTI 400S, TTI 600S, TTI 800S, TTI 900S

^(a) Applicable only to I-joist series listed above with a depth of 9-1/2 inches or greater.



Tolko Industries Ltd. Assembly TTI.P45.1

45-Minute Fire Resistance Rated Floor/Ceiling Assembly

This fire resistance design is listed in accordance with ASTM E119 and CAN/ULC S101
Min. 9-1/2 inches (241 mm) Deep: TTI 400S, TTI 600S, TTI 800S, and TTI 900S I-Joists

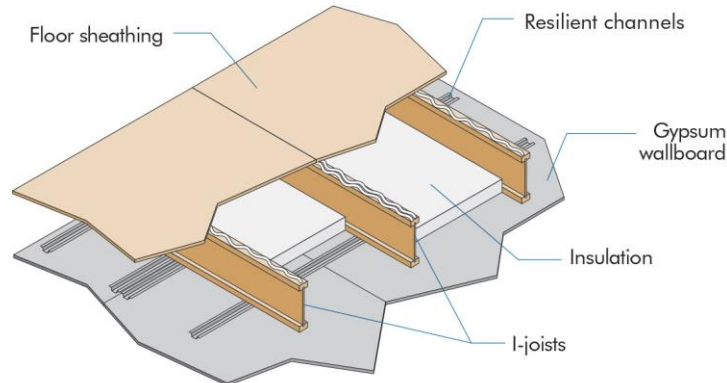

A. BASIC ASSEMBLIES

- 1) Floor Topping (Optional): Varies.
- 2) Floor Sheathing: Min. 5/8-inch (16-mm) T&G Wood Structural Panel when topping is used and the joist spacing is 19.2 inches (488 mm) or less. Otherwise, min. 3/4-inch (19-mm) T&G Wood Structural Panel must be used. The sheets shall be installed with their long edge perpendicular to I-joists with end joints centered over the top flange of I-joists and staggered. Floor sheathing must be installed per code requirements.
- 3) Insulation (Optional): 3-1/2-inch (89-mm) Glass Fiber Insulation Batts installed over joist flanges or min. 2-inch (51-mm) Mineral Wool Insulation Batts (nominal 2.5 pcf) friction fit between I-joist flanges.
- 4) Structural Members: Min. 9-1/2 inches (241 mm) Deep I-Joists. Max. 24 inches (610 mm) on center spacing. Min. flange dimensions of 1-1/2 inches (38 mm) thick by 2-1/2 inches (64 mm) wide. Min. web thickness of 3/8 inch (9.5 mm).
- 5) Resilient Channels: Min. 25 Gauge Galvanized Resilient Channels. Attached perpendicular to the bottom flange of the I-joist with 1-5/8 inch (41-mm) Type W drywall screws. Channels are spaced a max. of 16 inches (406 mm) on center, are doubled at each base layer wallboard end joint, and extend to the next joist beyond each joint.
- 6) Ceiling: One layer of 5/8-inch (16-mm) Type C Gypsum Wallboard. Installed with long dimension perpendicular to resilient channels and fastened with min. 1-1/8-inch (29-mm) Type S drywall screws spaced at 7 inches (178 mm) on center. The end joints of the wallboard must be staggered the equivalent of two joist spacings with those of adjacent sheets. Screws shall be min. 1-1/2 inches (38 mm) from board edges and 3/4 inch (19 mm) from board ends.
 - a) Finish: The face layer joints must be covered with tape and coated with joint compound. Screw heads must also be covered with joint compound.

B. SOUND RATINGS

Information not available

C. SIMILAR ASSEMBLIES

- 1) Intertek Listing IBI-MWP 45-01, and 2020 and 2015 NBC Table 9.10.3.1.-B and 2010 NBC Table A-9.10.3.1.B Assemblies F5, F8, F10, F14, and F20.
- 2) Assemblies that meet the fire-resistance rating in accordance with NBC Table 9.10.3.1.-B or the calculation method specified in NBC Appendix D-2.3.

REPRESENTING THE ENGINEERED WOOD INDUSTRY



Tolko Industries Ltd. Assembly TTI.P60.1
One-Hour Fire Resistance Rated Floor/Ceiling Assembly

This fire resistance design is listed in accordance with the ASTM E119 and CAN/ULC S101
Min. 9-1/2 inches (241 mm) Deep: TTI 800S and TTI 900S I-Joists

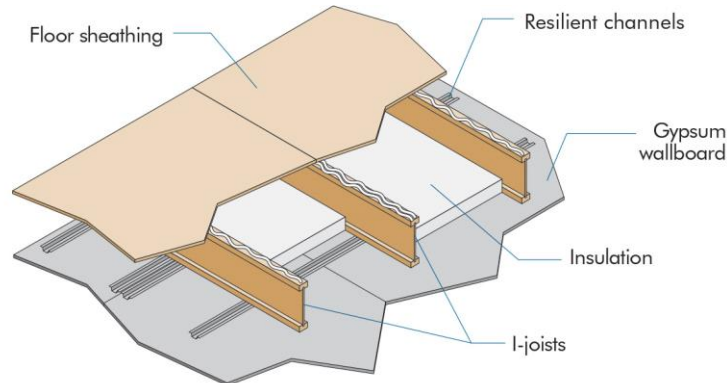

A. BASIC ASSEMBLIES

- 1) Floor Topping (Optional): Varies.
- 2) Floor Sheathing: Min. 5/8-inch (16-mm) T&G Wood Structural Panel when topping is used and the joist spacing is 19.2 inches (488 mm) or less. Otherwise, Min. 23/32-inch (18-mm) T&G Wood Structural Panel must be used. The sheets shall be installed with their long edge perpendicular to I-joists with end joints centered over the top flange of I-joists and staggered. Floor sheathing must be installed per code requirements.
- 3) Insulation: Min. 1-1/2-inch (38-mm) Mineral Wool Insulation Batts (nominal 2.5 pcf) friction fit between I-joist flanges.
- 4) Structural Members: Min. 9-1/2 inches (241 mm) Deep I-Joists. Max. 24 inches (610 mm) on center spacing. Min. flange dimensions of 1-1/2 inches (38 mm) thick by 3-1/2 inches (89 mm) wide. Min. web thickness of 3/8 inch (9.5 mm).
- 5) Resilient Channels: Min. 25 Gauge Galvanized Resilient Channels. Attached perpendicular to the bottom flange of the I-joist with 1-5/8 inch (41-mm) Type W drywall screws. Channels are spaced a max. of 16 inches (406 mm) on center, are doubled at each base layer wallboard end joint, and extend to the next joist beyond each joint.
- 6) Ceiling: One layer of 5/8-inch (16-mm) Type C Gypsum Wallboard. Installed with long dimension perpendicular to resilient channels and fastened with min. 1-1/8-inch (29-mm) Type S drywall screws spaced at 7 inches (178 mm) on center. The end joints of the wallboard must be staggered 48 inches (1219 mm) with those of adjacent sheets. Screws shall be min. 1-1/2 inches (38 mm) from board edges and 3/4 inch (19 mm) from board ends.
 - a) Finish: The face layer joints must be covered with tape and coated with joint compound. Screw heads must also be covered with joint compound.

B. SOUND RATINGS

Information not available

C. SIMILAR ASSEMBLIES

- 1) Intertek Listing IBI-MWP 60-01, and 2020 and 2015 NBC Table 9.10.3.1.-B and 2010 NBC Table A-9.10.3.1.B Assemblies F8, F10, F14, and F20.
- 2) Assemblies that meet the fire-resistance rating in accordance with NBC Table 9.10.3.1.-B or the calculation method specified in NBC Appendix D-2.3.

REPRESENTING THE ENGINEERED WOOD INDUSTRY



Tolko Industries Ltd. Assembly TTI.P60.2

One-Hour Fire Resistance Rated Floor/Ceiling Assembly

This fire resistance design is listed in accordance with the ASTM E119 and CAN/ULC S101
Min. 9-1/2 inches (241 mm) Deep: TTI 400S, TTI 600S, TTI 800S, and TTI 900S I-Joists

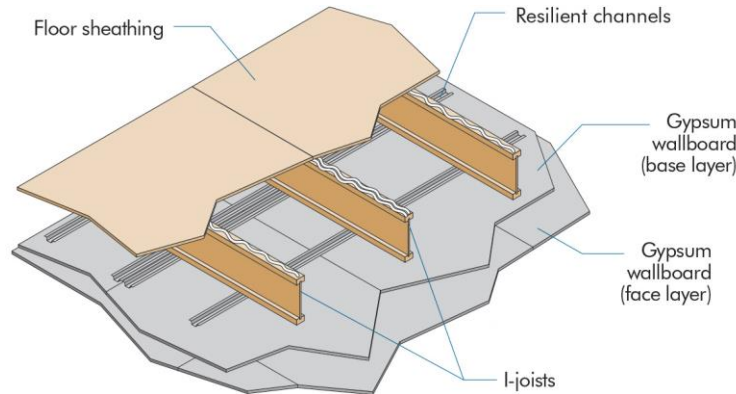

A. BASIC ASSEMBLIES

- 1) Floor Topping (Optional): Varies.
- 2) Floor Sheathing: Min. 5/8-inch (16-mm) T&G Wood Structural Panel when topping is used and the joist spacing is 19.2 inches (488 mm) or less. Otherwise, min. 3/4-inch (19-mm) T&G Wood Structural Panel must be used. A construction adhesive must be applied to the top of the joists prior to placing sheathing. The sheets shall be installed with their long edge perpendicular to I-joists with end joints centered over the top flange of I-joists and staggered. Floor sheathing must be installed per code requirements.
- 3) Insulation (Optional): Min. 3-1/2-inch (89-mm) Glass Fiber Insulation or Mineral Wool Insulation Batts friction fit between I-joist flanges except that when ceiling membrane is 5/8-inch (16-mm) Type C gypsum wallboard, the insulation thickness is not limited, but must be friction fit between I-joist flanges and webs.
- 4) Structural Members: Min. 9-1/2 inches (241 mm) Deep I-Joists. Max. 24 inches (610 mm) on center spacing. Min. flange dimensions of 1-1/2 inches (38 mm) thick by 2-1/2 inches (64 mm) wide. Min. web thickness of 3/8 inch (9.5 mm).
- 5) Resilient Channels: Min. 25 Gauge Galvanized Resilient Channels. Attached perpendicular to the bottom flange of the I-joist with 1-5/8 inch (41-mm) Type W drywall screws. Channels are spaced a max. of 16 inches (406 mm) on center, are doubled at each base layer wallboard end joint, and extend to the next joist beyond each joint.
- 6) Ceiling: Two layers of 1/2-inch (13-mm) Type X Gypsum Wallboard.
 - a) Base Layer: Install with long dimension perpendicular to resilient channels. Attach to the resilient channels using 1-1/8-inch (29-mm) Type S drywall screws at 12 inches (305 mm) on center. The end joints of the wallboard must be staggered a min. of 24 inches (610 mm).
 - b) Face Layer: Install with long dimension perpendicular to resilient channels. Attach to the resilient channels through the base layer using 1-5/8-inch (41-mm) Type S drywall screws spaced at 12 inches (305 mm) on center at intermediate supports and 1-1/2-inch (38-mm) Type W drywall screws spaced at 8 inches (203 mm) on center at end joints. Edge joints (long dimension) must be offset 24 inches (610 mm) from those of the base layer.
 - c) Finish: The face layer joints must be covered with tape and coated with joint compound. Screw heads must also be covered with joint compound.

B. SOUND RATINGS

Information not available

C. SIMILAR ASSEMBLIES

- 1) Intertek Listing IBI-MWP 60-02, and 2020 and 2015 NBC Table 9.10.3.1.-B and 2010 NBC Table A-9.10.3.1.B Assemblies F6, F9, F11, F15, F19, and F21.
- 2) Assemblies that meet the fire-resistance rating in accordance with NBC Table 9.10.3.1.-B or the calculation method specified in NBC Appendix D-2.3.

REPRESENTING THE ENGINEERED WOOD INDUSTRY



Tolko Industries Ltd. Assembly TTI.P60.3

One-Hour Fire Resistance Rated Floor/Ceiling Assembly

This fire resistance design is listed in accordance with the ASTM E119 and CAN/ULC S101
Min. 9-1/2 inches (241 mm) Deep: TTI 400S, TTI 600S, TTI 800S, and TTI 900S I-Joists

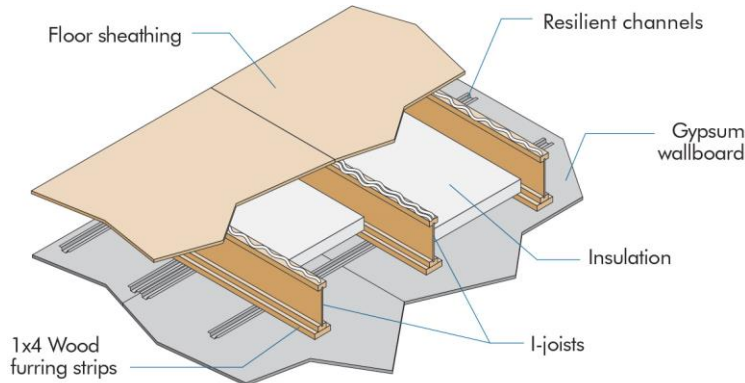

A. BASIC ASSEMBLIES

- 1) Floor Topping (Optional): Varies.
- 2) Floor Sheathing: Min. 5/8-inch (16-mm) T&G Wood Structural Panel when topping is used and the joist spacing is 19.2 inches (488 mm) or less. Otherwise, min. 3/4-inch (19-mm) T&G Wood Structural Panel must be used. A construction adhesive must be applied to the top of the joists prior to placing sheathing. The sheets shall be installed with their long edge perpendicular to I-joists with end joints centered over the top flange of I-joists and staggered. Floor sheathing must be installed per code requirements.
- 3) Insulation: Min. 2-inch (51-mm) Mineral Wool Insulation Batts (nominal 3.5 pcf) friction fit between I-joist webs, resting on wood furring strips.
- 4) Structural Members: Min. 9-1/2 inches (241 mm) Deep I-Joists. Max. 24 inches (610 mm) on center spacing. Min. flange dimensions of 1-1/2 inches (38 mm) thick by 2-1/2 inches (64 mm) wide. Min. web thickness of 3/8 inch (9.5 mm).
- 5) Wood Furring Strips: Min. nominal 1 inch (25 mm) x 4 inches (102 mm) attached with 1-1/4-inch (32-mm) Type W drywall screws at 24 inches (610 mm) on center along the bottom of the bottom flange of each I-joist.
- 6) Resilient Channels: Min. 25 Gauge Galvanized Resilient Channels. Attached perpendicular to the bottom flange of the I-joist with 1-5/8 inch (41-mm) Type W drywall screws. Channels are spaced a max. of 16 inches (406 mm) on center, are doubled at each base layer wallboard end joint, and extend to the next joist beyond each joint.
- 7) Ceiling: One layer of 5/8-inch (16-mm) Type C Gypsum Wallboard. Installed with long dimension perpendicular to resilient channels and fastened with min. 1-1/8-inch (29-mm) Type S drywall screws spaced at 7 inches (178 mm) on center. The end joints of the wallboard must be staggered 48 inches (1219 mm) with those of adjacent sheets. Screws shall be min. 1-1/2 inches (38 mm) from board edges and 3/4 inch (19 mm) from board ends.
 - a) Finish: The face layer joints must be covered with tape and coated with joint compound. Screw heads must also be covered with joint compound.

B. SOUND RATINGS

Information not available

C. SIMILAR ASSEMBLIES

- 1) Intertek Listing IBI-MWP 60-03, and 2020 and 2015 NBC Table 9.10.3.1.-B and 2010 NBC Table A-9.10.3.1.B Assemblies F8, F10, F14, and F20.
- 2) Assemblies that meet the fire-resistance rating in accordance with NBC Table 9.10.3.1.-B or the calculation method specified in NBC Appendix D-2.3.

REPRESENTING THE ENGINEERED WOOD INDUSTRY



Tolko Industries Ltd. Assembly TTI.P60.4
One-Hour Fire Resistance Rated Roof/Ceiling Assembly

This fire resistance design is listed in accordance with the ASTM E119 and CAN/ULC S101
Min. 9-1/2 inches (241 mm) Deep: TTI 800S and TTI 900S I-Joists

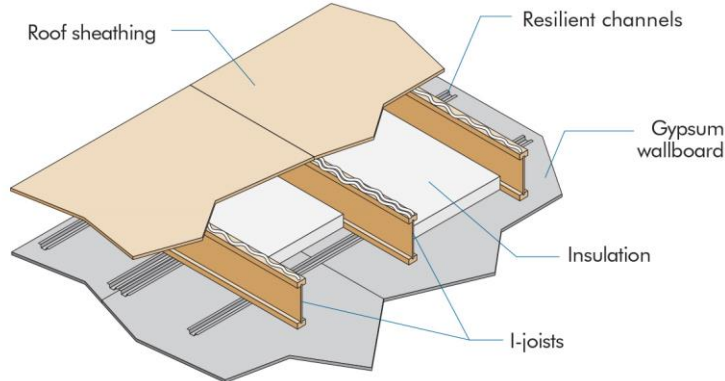

A. BASIC ASSEMBLIES

- 1) Roof Covering System: Insulation and roof covering materials intended for built-up covering that provides Class A, B, or C covering on combustible wood deck for fire resistant assemblies equivalent to this assembly.
- 2) Roof Sheathing: Min. 1/2-inch (13-mm) Wood Structural Panel. The sheets shall be installed with their long edge perpendicular to I-joists with end joints centered over the top flange of I-joists and staggered. Roof sheathing must be installed per code requirements.
- 3) Insulation: Min. 1-1/2-inch (38-mm) Mineral Wool Insulation Batts (nominal 2.5 pcf) friction fit between I-joint flanges.
- 4) Structural Members: Min. 9-1/2 inches (241 mm) Deep I-Joists. Max. 24 inches (610 mm) on center spacing. Min. flange dimensions of 1-1/2 inches (38 mm) thick by 3-1/2 inches (89 mm) wide. Min. web thickness of 3/8 inch (9.5 mm).
- 5) Resilient Channels: Min. 25 Gauge Galvanized Resilient Channels. Attached perpendicular to the bottom flange of the I-joint with 1-5/8 inch (41-mm) Type W drywall screws. Channels are spaced a max. of 16 inches (406 mm) on center, are doubled at each base layer wallboard end joint, and extend to the next joist beyond each joint.
- 6) Ceiling: One layer of 5/8-inch (16-mm) Type C Gypsum Wallboard. Installed with long dimension perpendicular to resilient channels and fastened with min. 1-1/8-inch (29-mm) Type S drywall screws spaced at 7 inches (178 mm) on center. The end joints of the wallboard must be staggered 48 inches (1219 mm) with those of adjacent sheets. Screws shall be min. 1-1/2 inches (38 mm) from board edges and 3/4 inch (19 mm) from board ends.
 - a) Finish: The face layer joints must be covered with tape and coated with joint compound. Screw heads must also be covered with joint compound.

B. SOUND RATINGS

Information not available

C. SIMILAR ASSEMBLIES

- 1) Intertek Listing IBI-MWP 60-04, and 2020 and 2015 NBC Table 9.10.3.1.-B and 2010 NBC Table A-9.10.3.1.B Assemblies F8, F10, F14, and F20.
- 2) Assemblies that meet the fire-resistance rating in accordance with NBC Table 9.10.3.1.-B or the calculation method specified in NBC Appendix D-2.3.

REPRESENTING THE ENGINEERED WOOD INDUSTRY



Tolko Industries Ltd. Assembly TTI.P60.5

One-Hour Fire Resistance Rated Floor/Ceiling Assembly

This fire resistance design is listed in accordance with the ASTM E119 and CAN/ULC S101
Superimposed Load \leq 51 psf (2.4 kPa); Load Restricted for Canadian Applications
Min. 14 inches (356 mm) Deep: TTI 600S, TTI 800S, and TTI 900S I-Joists

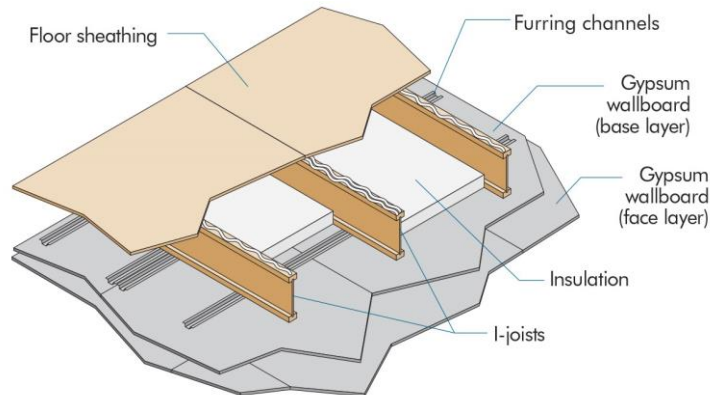

A. BASIC ASSEMBLIES

- 1) Floor Topping (Optional): Varies.
- 2) Floor Sheathing: Min. 23/32-inch (18-mm) T&G Wood Structural Panel. A construction adhesive meeting ASTM D3498 or AFG-01 must be applied to the top of I-joists and the flooring grooves prior to placing sheathing. The sheets shall be installed with their long edge perpendicular to I-joists with end joints centered over the top flange of I-joists and staggered. Floor sheathing must be installed per code requirements.
- 3) Insulation: 3-1/2-inch (89-mm) to 9-1/2-inch (241-mm) thick unfaced Glass Fiber Insulation Batts. When the insulation is less than 6-1/4 inches (159 mm) thick, insulation stay wires are required and must be spaced at a max. of 12 inches (305 mm) on center perpendicular to the joists. When the insulation is 6-1/4 inches (159 mm) or thicker, insulation stay wires are not required. Install insulation over the furring channels and gypsum wall boards. Press-fit insulation between the bottom flanges of the I-joists. Install insulation with ends butted over or between the furring channels. When needed, install insulation directly underneath the floor sheathing and hold insulation in place using insulation stay wires installed in accordance with the manufacturer's specification or spaced a max. of 12 inches (305 mm) on center, whichever is less.
- 4) Structural Members: Min. 14 inches (356 mm) Deep I-Joists. Max. 24 inches (610 mm) on center spacing. Min. flange dimensions of 1-1/2 inches (38 mm) thick by 2-1/2 inches (64 mm) wide. Min. web thickness of 3/8 inch (9.5 mm).
- 5) Furring Channels: Min. 1/2-inch (13-mm) Deep Nominal 25 Gauge Galvanized Steel Single Leg (RC-1) Channels or Min. 1/2-inch (13-mm) Deep x 2-1/2-inch (64-mm) Wide "Hat Shape" (RC-2) Channels. Attached perpendicular to the bottom flange of the I-joist with min. 1-1/4 inch (32-mm) Type W drywall screws. Channels are spaced a max. of 16 inches (406 mm) on center, are doubled at each base layer wallboard end joint, and extend to the next joist beyond each joint. When required for length, overlap the channel a min. of 6 inches (152 mm) and secure with 1-1/4 inch (32-mm) Type W drywall screws.
- 6) Ceiling: Two layers of 1/2-inch (13-mm) or 5/8-inch (16-mm) Type C Gypsum Wallboard.
 - a) Base Layer: Install with long dimension perpendicular to furring channels. Attach to the furring channels using 1-inch (25-mm) Type S drywall screws at 12 inches (305 mm) on center, 1-1/2 inches (38 mm) from the sides and 3/8 inch (9.5 mm) from end joints. The end joints of the wallboard must be staggered. Alternatively, for 1/2-inch (13-mm) Type C Gypsum Wallboard only, install with long dimension perpendicular to furring channels. Attach to the furring channels using 1-1/4-inch (32-mm) Type S drywall screws at 12 inches (305 mm) on center, 1-1/2 inches (38 mm) from the sides and 3/8 inch (9.5 mm) from end joints. The end joints of the wallboard must be staggered.

(continued on next page)

REPRESENTING THE ENGINEERED WOOD INDUSTRY



Tolko Industries Ltd. Assembly TTI.P60.5
One-Hour Fire Resistance Rated Floor/Ceiling Assembly (Continued)

- b) Face Layer: Install with long dimension perpendicular to furring channels. Attach to the furring channels through the base layer using 1-5/8-inch (41-mm) Type S drywall screws spaced at 8 inches (203 mm) on center, 1-1/2 inches (38 mm) from the sides. The longitudinal and end joints of this layer must be offset 24 inches (610 mm) from those of the base layer. Additionally, face layer end joints are attached to the base layer with 1-1/2-inch (38-mm) Type G drywall screws at 8 inches (203 mm) on center placed 1-1/2 inches (38 mm) either side of the joint. Alternatively, for 1/2-inch (13-mm) Type C Gypsum Wallboard only, install with long dimension perpendicular to furring channels. Attach to the furring channels through the base layer using 1-5/8-inch (41-mm) Type S drywall screws spaced at 12 inches (305 mm) on center, 1-1/2 inches (38 mm) from the sides. The longitudinal and end joints of this layer must be offset 24 inches (610 mm) from those of the base layer. Additionally, face layer end joints are attached to the base layer with 1-1/2-inch (38-mm) Type G drywall screws at 12 inches (305 mm) on center placed 1-1/2 inches (38 mm) either side of the joint.
- c) Finish: The face layer joints must be covered with tape and coated with joint compound. Screw heads must also be covered with joint compound.

B. SOUND RATINGS

Information not available

C. SIMILAR ASSEMBLIES

- 1) Intertek Listing IBI-WIJ 60-01, and 2020 and 2015 NBC Table 9.10.3.1.-B and 2010 NBC Table A-9.10.3.1.B Assemblies F6, F9, F11, F15, F19, and F21.
- 2) Assemblies that meet the fire-resistance rating in accordance with NBC Table 9.10.3.1.-B or the calculation method specified in NBC Appendix D-2.3.

REPRESENTING THE ENGINEERED WOOD INDUSTRY



Tolko Industries Ltd. Assembly TTI.P120.1

Two-Hour Fire Resistance Rated Floor/Ceiling Assembly

This fire resistance design is listed in accordance with the ASTM E119 and CAN/ULC S101
Min. 9-1/2 inches (241 mm) Deep: TTI 400S, TTI 600S, TTI 800S, and TTI 900S I-Joists

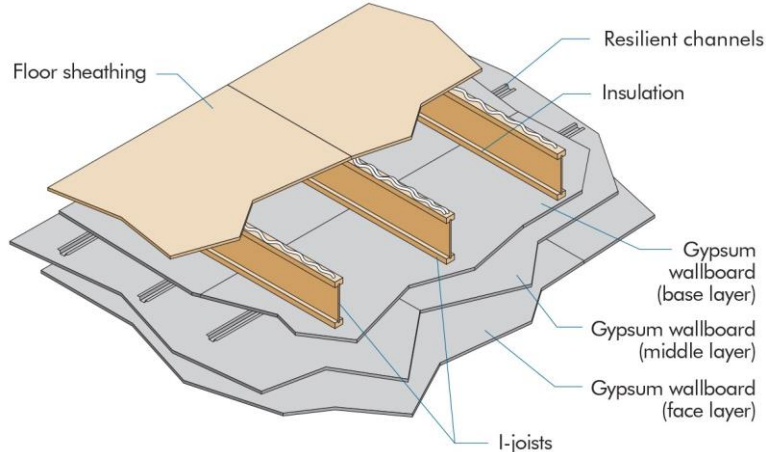

A. BASIC ASSEMBLIES

- 1) Floor Topping (Optional): Varies.
- 2) Floor Sheathing: Min. 5/8-inch (16-mm) T&G Wood Structural Panel when topping is used and the joist spacing is 19.2 inches (488 mm) or less. Otherwise, min. 23/32-inch (18-mm) T&G Wood Structural Panel must be used. The sheets shall be installed with their long edge perpendicular to I-joists with end joints centered over the top flange of I-joists and staggered. Floor sheathing must be installed per code requirements.
- 3) Insulation (Optional): Max. 6-inch (152-mm) Glass Fiber Insulation or Mineral Wool Insulation Batts friction fit between I-joint webs and supported by stay wires at 16 inches (406 mm) on center.
- 4) Structural Members: Min. 9-1/2 inches (241 mm) Deep I-Joists. Max. 24 inches (610 mm) on center spacing. Min. flange dimensions of 1-1/2 inches (38 mm) thick by 2-1/2 inches (64 mm) wide. Min. web thickness of 3/8 inch (9.5 mm).
- 5) Resilient Channels: Min. 25 Gauge Galvanized Resilient Channels. Attached perpendicular to the bottom flange of the I-joint with 1-5/8 inch (41-mm) Type S drywall screws. Channels are spaced a max. of 16 inches (406 mm) on center, are doubled at each base layer wallboard end joint, and extend to the next joist beyond each joint.
- 6) Ceiling: Three layers of 5/8-inch (16-mm) Type C Gypsum Wallboard.
 - a) Base Layer: Install with long dimension perpendicular to joist length. Attach to the bottom flange of the joists using 1-5/8-inch (41-mm) Type S drywall screws at 12 inches (305 mm) on center. The end joints of the wallboard must be centered on the bottom flange of the I-joint and must be staggered a min. of 24 inches (610 mm).
 - b) Middle Layer: Attached to resilient channels using 1-inch (25-mm) Type S drywall screws at 12 inches (305 mm) on center with the long dimension perpendicular to resilient channels. End joints must be staggered a min. of 24 inches (610 mm) from end joints of adjacent sheets and end joints on the face layer.
 - c) Face Layer: Attached to resilient channels through the middle layer using 1-5/8-inch (41-mm) Type S drywall screws spaced at 8 inches (203 mm) on center with long dimension perpendicular to resilient channel. End joints must be staggered from end joints of adjacent sheets and staggered from end joints on the middle layer. Edge joints (long dimension) must be offset 24 inches (610 mm) from those of the middle layer.
 - d) Finish: The face layer joints must be covered with tape and coated with joint compound. Screw heads must also be covered with joint compound.

B. SOUND RATINGS

Information not available

C. SIMILAR ASSEMBLIES

- 1) Intertek Listing IBI-MWP 120-01.
- 2) Assemblies that meet the fire-resistance rating in accordance with NBC Table 9.10.3.1.-B or the calculation method specified in NBC Appendix D-2.3.

REPRESENTING THE ENGINEERED WOOD INDUSTRY



Tolko Industries Ltd. Assembly TTI1.1

One-Hour Fire Resistance Rated Floor/Ceiling Assembly*

This fire resistance design is listed in accordance with the International Building Code (IBC) and American Wood Council's Design for Code Acceptance (DCA) 3

Min. 9-1/4 inches (235 mm) Deep: TTI 800S and TTI 900S I-Joists

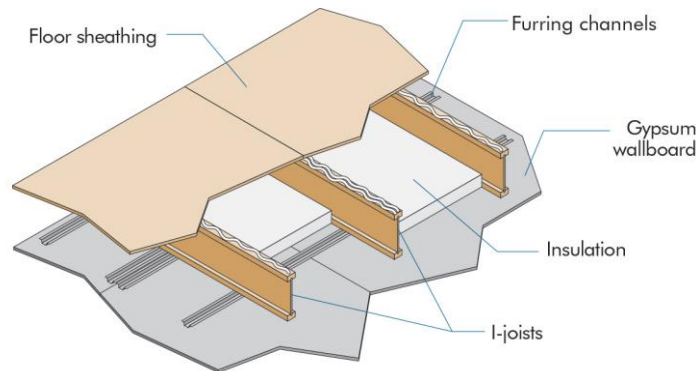

A. BASIC ASSEMBLIES

- 1) Floor Topping (Optional): Varies (reference sound ratings if applicable).
- 2) Floor Sheathing: Min. 23/32-inch (18-mm) T&G Wood Structural Panel. A construction adhesive must be applied to the top of the joists prior to placing sheathing. The sheets shall be installed with their long edge perpendicular to the joists with end joints centered over the top flange of joists. Floor sheathing must be installed per code requirements.
- 3) Insulation: Min. 1-1/2-inch (38-mm) Mineral Wool Insulation Batts (min. 2.5 pcf). Installed adjacent to the bottom flange of the I-joist and supported by the furring channels. Ends of batts shall be centered over furring channels.
- 4) Structural Members: Min. 9-1/4 inches (235 mm) Deep I-Joists. Max. 24 inch (610 mm) on center spacing. Min. flange thickness of 1-1/2 inches (38 mm) and each flange area of at least 5.25 inches² (3,387 mm²). Min. web thickness of 3/8 inch (9.5 mm).
- 5) Furring Channels: Min. 0.026-inch (0.66-mm) Hat Shaped Galvanized Steel Channels attached perpendicular to the bottom flange of the I-joist with 1-5/8-inch (41-mm) Type S drywall screws. Channels are spaced a max. of 16 inches (406 mm) on center, are doubled at each wallboard end joint, and extend to the next joist beyond each joint.
- 6) Ceiling: One layer of 5/8-inch (16-mm) Type C Gypsum Wallboard. Installed with long dimension perpendicular to furring channels and fastened with min. 1-1/8-inch (29-mm) Type S drywall screws spaced at 12 inches (305 mm) on center on intermediate joists and 8 inches (203 mm) on center at end joints, and 3/4 inch (19 mm) from wallboard edges and ends. The end joints of the wallboard must be staggered.
 - a) Finish: The face layer joints must be covered with tape and coated with joint compound. Screw heads must also be covered with joint compound.

B. SOUND RATING (with Resilient Channels)^(a,b)

Joist/RC Spacing ^(c)	Without Gypsum Concrete				With 1-in. (25-mm) Gypsum Concrete			
	Cushioned Vinyl		Carpet & Pad		Cushioned Vinyl		Carpet & Pad	
	STC	IIC	STC	IIC	STC	IIC	STC	IIC
24"/16" o.c.	48 (51)	42 (43)	48 (51)	61 (63)	63 (65)	50 (52)	63 (65)	65 (67)
16"/16" o.c.	44 (46)	37 (39)	44 (46)	60 (61)	56 (57)	46 (47)	56 (57)	58 (59)

^(a) Sound ratings from the American Wood Council publication Design for Code Acceptance (DCA) 3, available from www.awc.org.

^(b) STC and IIC values established by engineering analysis based on 1.5-in. (38-mm) thick mineral wool batt insulation. Values in parentheses are based on 3.5-in. (89-mm) thick mineral wool batt insulation.

^(c) STC and IIC values for 16 in. (406 mm) o.c. joist spacing are applicable to 19.2-in. (488 mm) o.c. joist spacing.

C. SIMILAR ASSEMBLIES

- 1) 2015/2018/2021/2024 IBC Table 721.1(3) Item 24-1.1 and DCA 3 WIJ-1.1.
- 2) Assemblies that meet the fire-resistance rating in accordance with NBC Table 9.10.3.1.-B or the calculation method specified in NBC Appendix D-2.3.

* This assembly may also be used in a fire-rated roof/ceiling assembly, but only when constructed exactly as described.

REPRESENTING THE ENGINEERED WOOD INDUSTRY



Tolko Industries Ltd. Assembly TTI1.2

One-Hour Fire Resistance Rated Floor/Ceiling Assembly*

This fire resistance design is listed in accordance with the International Building Code (IBC) and American Wood Council's Design for Code Acceptance (DCA) 3

Min. 9-1/4 inches (235 mm) Deep: TTI 900S I-Joists

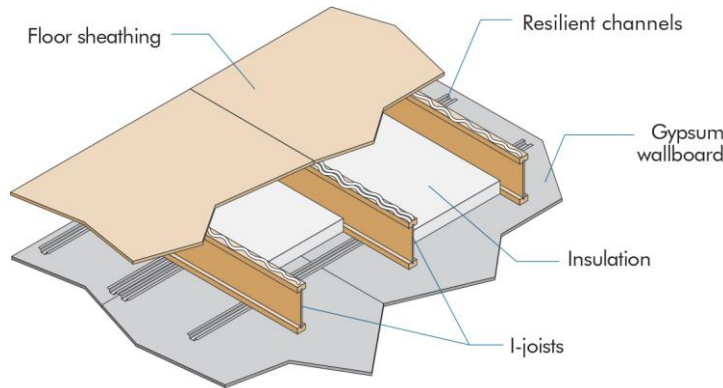

A. BASIC ASSEMBLIES

- 1) Floor Topping (Optional): Varies (reference sound ratings if applicable).
- 2) Floor Sheathing: Min. 23/32-inch (18-mm) T&G Wood Structural Panel. A construction adhesive must be applied to the top of the joists prior to placing sheathing. The sheets shall be installed with their long edge perpendicular to the joists with end joints centered over the top flange of joists. Floor sheathing must be installed per code requirements.
- 3) Insulation: Min. 1-1/2-inch (38-mm) Mineral Wool Insulation Batts (min. 2.5 pcf). Installed adjacent to the bottom flange of the I-joist and supported by the resilient channels. The ends of the batts shall be centered over resilient channels.
- 4) Structural Members: Min. 9-1/4 inches (235 mm) Deep I-Joists. Max. 24 inches (610 mm) on center spacing. Min. flange thickness of 1-1/2 inches (38 mm) and each flange area of at least 5.25 inches² (3,387 mm²). Min. web thickness of 7/16 inch (11 mm).
- 5) Resilient Channels: Min. 0.019-inch (0.5-mm) Galvanized Resilient Channels. Attached perpendicular to the bottom flange of the I-joist with 1-5/8-inch (41-mm) Type S drywall screws. Channels are spaced a max. of 16 inches (406 mm) on center, are doubled at each wallboard end joint, and extend to the next joist beyond each joint.
- 6) Ceiling: One layer of 5/8-inch (16-mm) Type C Gypsum Wallboard. Installed with long dimension perpendicular to resilient channels and fastened with min. 1-inch (25-mm) Type S drywall screws spaced at 12 inches (305 mm) on center on intermediate joists and 8 inches (203 mm) on center at end joints, and 3/4 inch (19 mm) from wallboard edges and ends. The end joints of the wallboard must be staggered.
 - a) Finish: The face layer joints must be covered with tape and coated with joint compound. Screw heads must also be covered with joint compound.

B. SOUND RATING^(a,b)

Joist/RC Spacing ^(c)	Without Gypsum Concrete				With 1-in. (25-mm) Gypsum Concrete			
	Cushioned Vinyl		Carpet & Pad		Cushioned Vinyl		Carpet & Pad	
	STC	IIC	STC	IIC	STC	IIC	STC	IIC
24"/16" o.c.	48 (51)	42 (43)	48 (51)	61 (63)	63 (65)	50 (52)	63 (65)	65 (67)
16"/16" o.c.	44 (46)	37 (39)	44 (46)	60 (61)	56 (57)	46 (47)	56 (57)	58 (59)

^(a) Sound ratings from the American Wood Council publication Design for Code Acceptance (DCA) 3, available from www.awc.org.

^(b) STC and IIC values established by engineering analysis based on 1.5-in. (38-mm) thick mineral wool batt insulation. Values in parentheses are based on 3.5-in. (89-mm) thick mineral wool batt insulation.

^(c) STC and IIC values for 16 in. (406 mm) o.c. joist spacing are applicable to 19.2-in. (488 mm) o.c. joist spacing.

C. SIMILAR ASSEMBLIES

- 1) 2015/2018/2021/2024 IBC Table 721.1(3) Item 25-1.1 and DCA 3 WIJ-1.2.
- 2) Assemblies that meet the fire-resistance rating in accordance with NBC Table 9.10.3.1.-B or the calculation method specified in NBC Appendix D-2.3.

* This assembly may also be used in a fire-rated roof/ceiling assembly, but only when constructed exactly as described.

REPRESENTING THE ENGINEERED WOOD INDUSTRY



Tolko Industries Ltd. Assembly TTI1.3

One-Hour Fire Resistance Rated Floor/Ceiling Assembly*

This fire resistance design is listed in accordance with the International Building Code (IBC) and American Wood Council's Design for Code Acceptance (DCA) 3

Min. 9-1/4 inches (235 mm) Deep: TTI 400S, TTI 600S, TTI 800S, and TTI 900S I-Joists

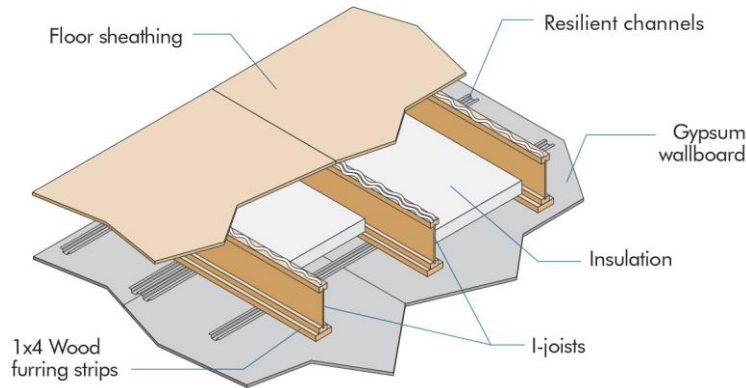

A. BASIC ASSEMBLIES

- 1) Floor Topping (Optional): Varies (reference sound ratings if applicable).
- 2) Floor Sheathing: Min. 23/32-inch (18-mm) T&G Wood Structural Panel. The sheets shall be installed with their long edge perpendicular to the joists with end joints centered over the top flange of joists. Floor sheathing must be installed per code requirements.
- 3) Insulation: Min. 2-inch (51-mm) Mineral Wool Insulation Batts (min. 3.5 pcf). Installed adjacent to the bottom flange of the I-joist and supported by 1x4 wood furring strip spacer. The ends of the batts shall be centered over resilient channels.
- 4) Structural Members: Min. 9-1/4 inches (235 mm) Deep I-Joists. Max. 24 inches (610 mm) on center spacing. Min. flange thickness of 1-5/16 inches (33 mm) and each flange area of at least 2.25 inches² (1,452 mm²). Min. web thickness of 3/8 inch (9.5 mm).
- 5) Wood Furring Strip Spacers: Min. nominal 1 inch (25 mm) x 4 inches (102 mm) attached with 1-1/2-inch (38-mm) long drywall screws at 24 inches (610 mm) on center along the bottom of the bottom flange of each I-joist.
- 6) Resilient Channels: Min. 0.019-inch (0.5-mm) Galvanized Resilient Channels (1/2-inch or 13-mm deep single leg). Attached perpendicular to the wood furring strip and bottom flange of the I-joist with 1-7/8 inch (48-mm) Type S drywall screws. Channels are spaced a max. of 16 inches (406 mm) on center, are doubled at each wallboard end joint, and extend to the next joint beyond each joint.
- 7) Ceiling: One layer of 5/8-inch (16-mm) Type C Gypsum Wallboard. Installed with long dimension perpendicular to resilient channels and fastened with min. 1-1/8-inch (29-mm) Type S drywall screws spaced at 7 inches (178 mm) on center, and 3/4 inch (19 mm) from wallboard edges and ends. The end joints of the wallboard must be staggered.
 - a) Finish: The face layer joints must be covered with tape and coated with joint compound. Screw heads must also be covered with joint compound.

B. SOUND RATING^(a,b)

Joist/RC Spacing ^(c)	Without Gypsum Concrete				With 1-in. (25-mm) Gypsum Concrete			
	Cushioned Vinyl		Carpet & Pad		Cushioned Vinyl		Carpet & Pad	
	STC	IIC	STC	IIC	STC	IIC	STC	IIC
24"/16" o.c.	50 (51)	43 (43)	52	66	63 (65)	51 (52)	63 (65)	67 (67)
16"/16" o.c.	45 (46)	38 (39)	45 (46)	60 (61)	57 (57)	46 (47)	57 (57)	59 (59)

^(a) Sound ratings from the American Wood Council publication Design for Code Acceptance (DCA) 3, available from www.awc.org.

^(b) STC and IIC values established by engineering analysis based on 1.5-in. (38-mm) thick mineral wool batt insulation. Values in parentheses are based on 3.5-in. (89-mm) thick mineral wool batt insulation.

^(c) STC and IIC values for 16 in. (406 mm) o.c. joist spacing are applicable to 19.2-in. (488 mm) o.c. joist spacing.

C. SIMILAR ASSEMBLIES

- 1) 2015/2018/2021/2024 IBC Table 721.1(3) Item 23-1.1 and DCA 3 WIJ-1.3.
- 2) Assemblies that meet the fire-resistance rating in accordance with NBC Table 9.10.3.1.-B or the calculation method specified in NBC Appendix D-2.3.

* This assembly may also be used in a fire-rated roof/ceiling assembly, but only when constructed exactly as described.

REPRESENTING THE ENGINEERED WOOD INDUSTRY



Tolko Industries Ltd. Assembly TTI1.4
One-Hour Fire Resistance Rated Floor/Ceiling Assembly*

This fire resistance design is listed in accordance with *American Wood Council's Design for Code Acceptance (DCA) 3*
Min. 9-1/4 inches (235 mm) Deep: TTI 400S, TTI 600S, TTI 800S, and TTI 900S I-Joists

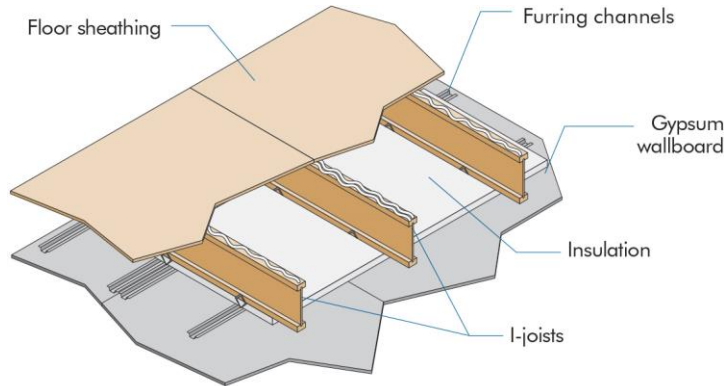

A. BASIC ASSEMBLIES

- 1) Floor Topping (Optional): Varies (reference sound ratings if applicable).
- 2) Floor Sheathing: Min. 23/32-inch (18-mm) T&G Wood Structural Panel. The sheets shall be installed with their long edge perpendicular to the joists with end joints centered over the top flange of joists. Floor sheathing must be installed per code requirements.
- 3) Insulation: Min. 1-inch (25-mm) Mineral Wool Insulation Batts (min. 6 pcf) with width equal to on-center spacing of the I-joists. Installed below the bottom flange of the I-joist and on top of furring channels with sides butted against support clips. The ends of the batts shall be centered over furring channels with batts tightly butted at all joints.
- 4) Structural Members: Min. 9-1/4 inches (235 mm) Deep I-Joists. Max. 24 inches (610 mm) on center spacing. Min. flange thickness of 1-1/2 inches (38 mm) and each flange area of at least 3.45 inches² (2,226 mm²). Min. web thickness of 3/8 inch (9.5 mm).
- 5) Furring Channels: Min. 0.019-inch (0.5-mm) Hat Shaped Galvanized Steel Channels attached perpendicular to the bottom flange of the I-joist with Simpson Type CSC support clips at each intersection with the I-joists. Clips nailed to the side of bottom flange with one 1-1/2-inch (38-mm) long No. 11 gage nail. Channels are spaced a max. of 24 inches (610 mm) on center, are doubled at each wallboard end joint, and extend to the next joist beyond each joint. At channel splices, adjacent pieces overlapped a minimum of 6 inches (152 mm) and tied with a double strand of No. 18 gage galvanized steel wire at each end of the overlap. A row of furring channel located on each side of wallboard end joints and spaced 2-1/4 inches (57 mm) from the end joint (4-1/2 inches or 114 mm on center).
- 6) Ceiling: One layer of 1/2-inch (13-mm) Type C Gypsum Wallboard. Installed with long dimension perpendicular to furring channels and fastened with min. 1-inch (25-mm) Type S drywall screws spaced at 12 inches (305 mm) on center on intermediate joists, 6 inches (152 mm) on center at end joints, and 3/4 inch (19 mm) from wallboard edges and ends. The end joints of the wallboard must be staggered and the furring channels must extend a min. of 6 inches (152 mm) beyond each end of the joint.
 - a) Finish: The face layer joints must be covered with tape and coated with joint compound. Screw heads must also be covered with joint compound.

B. SOUND RATING^(a,b)

Joist/RC Spacing	Without Gypsum Concrete				With 3/4-in. (19-mm) Gypsum Concrete			
	Cushioned Vinyl		Carpet & Pad		Cushioned Vinyl		Carpet & Pad	
	STC	IIC	STC	IIC	STC	IIC	STC	IIC
24"/24" o.c.	--	--	46	68	51	47	50	73

^(a) Sound ratings from the American Wood Council publication Design for Code Acceptance (DCA) 3, available from www.awc.org.

^(b) STC and IIC values are based on tests of assemblies with 5/8-in. (15.9-mm) thick gypsum boards.

C. SIMILAR ASSEMBLIES

- 1) DCA 3 WIJ-1.4.
- 2) Assemblies that meet the fire-resistance rating in accordance with NBC Table 9.10.3.1.-B or the calculation method specified in NBC Appendix D-2.3.

* This assembly may also be used in a fire-rated roof/ceiling assembly, but only when constructed exactly as described.

REPRESENTING THE ENGINEERED WOOD INDUSTRY



Tolko Industries Ltd. Assembly TTI1.5

One-Hour Fire Resistance Rated Floor/Ceiling Assembly*

This fire resistance design is listed in accordance with *American Wood Council's Design for Code Acceptance (DCA) 3*
Min. 9-1/4 inches (235 mm) Deep: TTI 400S, TTI 600S, TTI 800S, and TTI 900S I-Joists

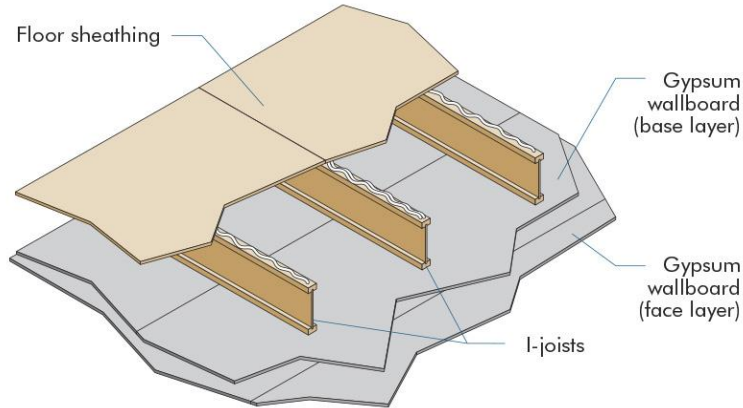

A. BASIC ASSEMBLIES

- 1) Floor Topping (Optional): Varies (reference sound ratings if applicable).
- 2) Floor Sheathing: Min. 23/32-inch (18-mm) T&G Wood Structural Panel. The sheets shall be installed with their long edge perpendicular to the joists with end joints centered over the top flange of joists. Floor sheathing must be installed per code requirements.
- 3) Structural Members: Min. 9-1/4 inches (235 mm) Deep I-Joists. Max. 24 inches (610 mm) on center spacing. Min. flange thickness of 1-1/2 inches (38 mm) and each flange area of at least 2.25 inches² (1,452 mm²). Min. web thickness of 3/8 inch (9.5 mm).
- 4) Ceiling: Two layers of 1/2-inch (13-mm) Type C Gypsum Wallboard.
 - a) Base Layer: Install with long dimension perpendicular to joist length. Attach to the bottom flange of the joists using 1-inch (25-mm) Type S drywall screws at 12 inches (305 mm) on center. The end joints of the wallboard must be centered on the bottom flange of the joist and must be staggered.
 - b) Face Layer: Install with long dimension perpendicular to joist length. Attach to the bottom flange of the joists through the base layer using 1-5/8-inch (41-mm) Type S drywall screws spaced at 12 inches (305 mm) on center on intermediate joists and 8 inches (203 mm) on center at end joints. The longitudinal joints of this layer must be offset 24 inches (610 mm) from those of the base layer. The end joints must be centered on the bottom flange of the joists and offset a min. of 48 inches (1219 mm) from those of the base layer. Additionally, face layer end joints are attached to the base layer with 1-1/2-inch (38-mm) Type G drywall screws at 8 inches (203 mm) on center with a 4-inch (102-mm) stagger, placed 6 inches (152 mm) either side of the joint.
 - c) Finish: The face layer joints must be covered with tape and coated with joint compound. Screw heads must also be covered with joint compound.

B. SOUND RATING^(a,b)

Joist Spacing	Without Gypsum Concrete				With 3/4-in. (19-mm) Gypsum Concrete			
	Cushioned Vinyl		Carpet & Pad		Cushioned Vinyl		Carpet & Pad	
	STC	IIC	STC	IIC	STC	IIC	STC	IIC
24" o.c.	--	--	--	--	--	--	49	55

^(a) Sound ratings from the American Wood Council publication *Design for Code Acceptance (DCA) 3*, available from www.awc.org.

^(b) STC and IIC values are based on engineering analysis performed by David L. Adams Associates, Inc.

C. SIMILAR ASSEMBLIES

- 1) 2024 IBC Table 721.1(3) Item 31-1.1, and DCA 3 WIJ-1.5.
- 2) Assemblies that meet the fire-resistance rating in accordance with NBC Table 9.10.3.1.-B or the calculation method specified in NBC Appendix D-2.3.

* This assembly may also be used in a fire-rated roof/ceiling assembly, but only when constructed exactly as described.

REPRESENTING THE ENGINEERED WOOD INDUSTRY



Tolko Industries Ltd. Assembly TTI1.6
One-Hour Fire Resistance Rated Floor/Ceiling Assembly*

This fire resistance design is listed in accordance with *American Wood Council's Design for Code Acceptance (DCA) 3*
Min. 9-1/2 inches (241 mm) Deep: TTI 400S, TTI 600S, TTI 800S, and TTI 900S I-Joists

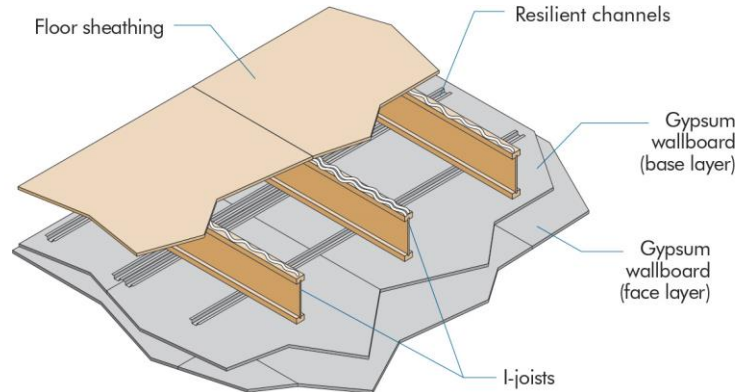

A. BASIC ASSEMBLIES

- 1) Floor Topping (Optional): Varies (reference sound ratings if applicable).
- 2) Floor Sheathing: Min. 23/32-inch (18-mm) T&G Wood Structural Panel. The sheets shall be installed with their long edge perpendicular to the joists with end joints centered over the top flange of joists. Floor sheathing must be installed per code requirements.
- 3) Structural Members: Min. 9-1/2 inches (241 mm) Deep I-Joists. Max. 24 inch (610 mm) on center spacing. Min. flange thickness of 1-5/16 inches (33 mm) and each flange area of at least 1.95 inches² (1,258 mm²). Min. web thickness of 3/8 inch (9.5 mm).
- 4) Resilient Channels†: Min. 0.019-inch (0.5-mm) Galvanized Resilient Channels. Attached perpendicular to the bottom flange of the I-joist with 1-1/4-inch (32-mm) Type S drywall screws. Channels are spaced a max. of 16 inches (406 mm) on center (24 inches or 610 mm when I-joists are spaced a max. of 16 inches or 406 mm on center), are doubled at each base layer wallboard end joint, and extend to the next joist beyond each joint.
- 5) Ceiling: Two layers of 1/2-inch (13-mm) Type X Gypsum Wallboard.
 - a) Base Layer: Install with long dimension perpendicular to resilient channels. Attach to the resilient channels using 1-1/4 inch (32-mm) Type S drywall screws at 12 inches (305 mm) on center. The end joints of the wallboard must be staggered.
 - b) Face Layer: Install with long dimension perpendicular to resilient channels. Attach to the resilient channels through the base layer using 1-5/8-inch (41-mm) Type S drywall screws spaced at 12 inches (305 mm) on center. The longitudinal joints of this layer must be offset 24 inches (610 mm) from those of the base layer. Additionally, face layer end joints are attached to the base layer with 1-1/2-inch (38-mm) Type G drywall screws at 8 inches (203 mm) on center placed 1-1/2 inches (38 mm) either side of the joint.
 - c) Finish: The face layer joints must be covered with tape and coated with joint compound. Screw heads must also be covered with joint compound.

B. SOUND RATING^(a,b)

Joist/RC Spacing ^(c)	Without Gypsum Concrete				With 1-in. (25-mm) Gypsum Concrete			
	Cushioned Vinyl		Carpet & Pad		Cushioned Vinyl		Carpet & Pad	
	STC	IIC	STC	IIC	STC	IIC	STC	IIC
24"/16" o.c.	46	44	46	61	58	47 (51)	58	67
16"/24" o.c.	47	43	47	64	60	49 (52)	60	67

^(a) Sound ratings from the American Wood Council publication *Design for Code Acceptance (DCA) 3*, available from www.awc.org.
^(b) STC and IIC values established by engineering analysis. Values in parentheses are based on laminate wood flooring over a 0.08-in. (2-mm) closed-cell foam underlay, in lieu of cushioned vinyl flooring.
^(c) STC and IIC values for 16 in. (406 mm) o.c. joist spacing are applicable to 19.2-in. (488 mm) o.c. joist spacing.

C. SIMILAR ASSEMBLIES

- 1) 2015/2018/2021/2024 IBC Table 721.1(3) Item 27-1.1 and DCA 3 WIJ-1.6.
- 2) Assemblies that meet the fire-resistance rating in accordance with NBC Table 9.10.3.1.-B or the calculation method specified in NBC Appendix D-2.3.

* This assembly may also be used in a fire-rated roof/ceiling assembly, but only when constructed exactly as described.
 † Direct attachment of gypsum wallboard in lieu of attachment to resilient channels is typically deemed acceptable. When gypsum wallboard is directly attached to the I-joists, the wallboard shall be installed with the long dimension perpendicular to the I-joists and sound rating for TTI1.5 Assembly shall be used.

REPRESENTING THE ENGINEERED WOOD INDUSTRY



Tolko Industries Ltd. Assembly TTI1.7

One-Hour Fire Resistance Rated Floor/Ceiling Assembly*

This fire resistance design is listed in accordance with *American Wood Council's Design for Code Acceptance (DCA) 3*
Min. 9-1/2 inches (241 mm) Deep: TTI 400S, TTI 600S, TTI 800S, and TTI 900S I-Joists

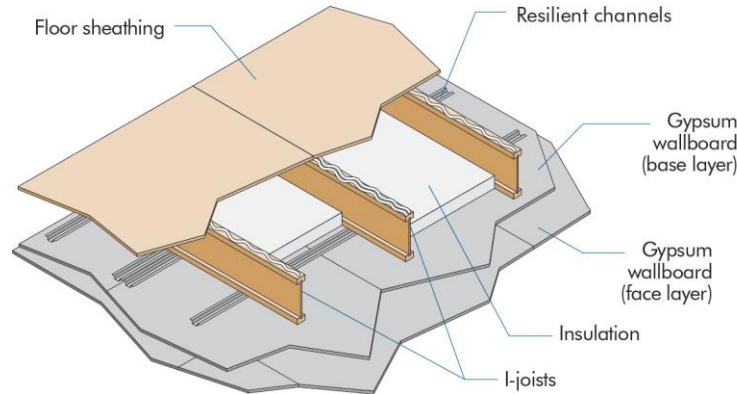

A. BASIC ASSEMBLIES

- 1) Floor Topping (Optional): Varies (reference sound ratings if applicable).
- 2) Floor Sheathing: Min. 23/32-inch (18-mm) T&G Wood Structural Panel. The sheets shall be installed with their long edge perpendicular to the joists with end joints centered over the top flange of joists. Floor sheathing must be installed per code requirements.
- 3) Insulation: Glass Fiber Insulation. Installed between I-joists and supported by resilient channels.
- 4) Structural Members: Min. 9-1/2 inches (241 mm) Deep I-Joists. Max. 24 inches (610 mm) on center spacing. Min. flange thickness of 1-1/2 inches (38 mm) and each flange area of at least 2.25 inches² (1,452 mm²). Min. web thickness of 3/8 inch (9.5 mm).
- 5) Resilient Channels: Min. 0.019-inch (0.5-mm) Galvanized Resilient Channels. Attached perpendicular to the bottom flange of the I-joist with 1-1/4 inch (32-mm) Type S drywall screws. Channels are spaced a max. of 16 inches (406 mm) on center (24 inches or 610 mm when I-joists are spaced a max. of 16 inches or 406 mm on center), are doubled at each base layer wallboard end joint, and extend to the next joist beyond each joint..
- 6) Ceiling: Two layers of 1/2-inch (13-mm) Type X Gypsum Wallboard.
 - a) Base Layer: Install with long dimension perpendicular to resilient channels. Attach to the resilient channels using 1-1/4 inch (32-mm) Type S drywall screws at 12 inches (305 mm) on center. The end joints of the wallboard must be staggered.
 - b) Face Layer: Install with long dimension perpendicular to resilient channels. Attach to the resilient channels through the base layer using 1-5/8-inch (41-mm) Type S drywall screws spaced at 12 inches (305 mm) on center. The longitudinal joints of this layer must be offset 24 inches (610 mm) from those of the base layer. Additionally, face layer end joints are attached to the base layer with 1-1/2-inch (38-mm) Type G drywall screws at 8 inches (203 mm) on center placed 1-1/2 inches (38 mm) either side of the joint.
 - c) Finish: The face layer joints must be covered with tape and coated with joint compound. Screw heads must also be covered with joint compound.

B. SOUND RATING^(a,b)

Joist/RC Spacing ^(c)	Without Gypsum Concrete				With 1-in. (25-mm) Gypsum Concrete			
	Cushioned Vinyl		Carpet & Pad		Cushioned Vinyl		Carpet & Pad	
	STC	IIC	STC	IIC	STC	IIC	STC	IIC
24"/16" o.c.	56	51	56	69	64	53	64	71
16"/24" o.c.	55	48 (51)	55	67	64	54	64	67

^(a) Sound ratings from the American Wood Council publication Design for Code Acceptance (DCA) 3, available from www.awc.org.

^(b) STC and IIC values established by engineering analysis based on 3.5-in. (89-mm) thick glass fiber insulation. Values in parentheses are based on laminate wood flooring over a 0.08-in. (2-mm) closed-cell foam underlay, in lieu of cushioned vinyl flooring.

^(c) STC and IIC values for 16 in. (406 mm) o.c. joist spacing are applicable to 19.2-in. (488 mm) o.c. joist spacing.

C. SIMILAR ASSEMBLIES

- 1) 2015/2018/2021/2024 IBC Table 721.1.(3) Item 30-1.1 and DCA 3 WIJ-1.7.
- 2) Assemblies that meet the fire-resistance rating in accordance with NBC Table 9.10.3.1.-B or the calculation method specified in NBC Appendix D-2.3.

* This assembly may also be used in a fire-rated roof/ceiling assembly, but only when constructed exactly as described.

REPRESENTING THE ENGINEERED WOOD INDUSTRY



Tolko Industries Ltd. Assembly TTI1.8

One-Hour Fire Resistance Rated Floor/Ceiling Assembly*

This fire resistance design is listed in accordance with the International Building Code (IBC)
TTI 400S, TTI 600S, TTI 800S, and TTI 900S I-Joists

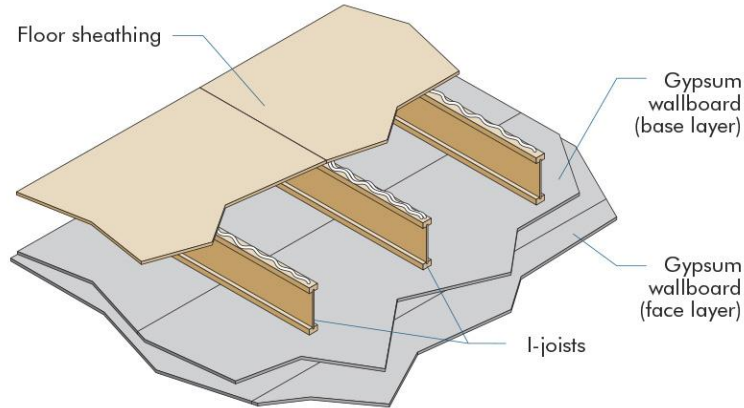

A. BASIC ASSEMBLIES

- 1) Floor Topping (Optional): Varies (reference sound ratings if applicable).
- 2) Floor Sheathing: Min. 23/32-inch (18-mm) T&G Wood Structural Panel. The sheets shall be installed with their long edge perpendicular to the joists with end joints centered over the top flange of joists. Floor sheathing must be installed per code requirements.
- 3) Structural Members: Min. 9-1/4 inches (235 mm) Deep I-Joists. Max. 24 inches (610 mm) on center spacing. Min. flange thickness of 1-1/2 inches (38 mm) and each flange area of at least 2.25 inches² (1,452 mm²). Min. web thickness of 3/8 inch (9.5 mm).
- 4) Ceiling: Two layers of 1/2-inch (13-mm) Type X Gypsum Wallboard.
 - a) Base Layer: Install with long dimension perpendicular to joist length. Attach to the bottom flange of the joists using 1-5/8-inch (41-mm) Type S drywall screws at 12 inches (305 mm) on center. The end joints of the wallboard must be centered on the bottom flange of the joist and must be staggered the equivalent of two joist spacings with those of adjacent sheets.
 - b) Face Layer: Install with long dimension perpendicular to joist length. Attach to the bottom flange of the joists through the base layer using 2-inch (51-mm) Type S drywall screws spaced at 12 inches (305 mm) on center on intermediate joists and 8 inches (203 mm) on center at end joints. Face layer end joint must not occur on the same joist as base layer end joints. The longitudinal joints of this layer must be offset 24 inches (610 mm) from those of the base layer. Additionally, face layer end joints are attached to the base layer with 1-1/2-inch (38-mm) Type G drywall screws at 8 inches (203 mm) on center placed 6 inches (152 mm) either side of the joint.
 - c) Finish: The face layer joints must be covered with tape and coated with joint compound. Screw heads must also be covered with joint compound.

B. SOUND RATING

Information not available.

C. SIMILAR ASSEMBLIES

- 1) 2015/2018/2021/2024 IBC Table 721.1(3) Item 26-1.1.
- 2) Assemblies that meet the fire-resistance rating in accordance with NBC Table 9.10.3.1.-B or the calculation method specified in NBC Appendix D-2.3.

* This assembly may also be used in a fire-rated roof/ceiling assembly, but only when constructed exactly as described.

REPRESENTING THE ENGINEERED WOOD INDUSTRY



Tolko Industries, Ltd. Assembly TTI1.9

One-Hour Fire Resistance Rated Floor/Ceiling Assembly*†

This fire resistance design is listed in accordance with the ASTM E119 and CAN/ULC S101
Min. 9-1/2 inches (241 mm) Deep: TTI 400S, TTI 600S, TTI 800S, and TTI 900S I-Joists

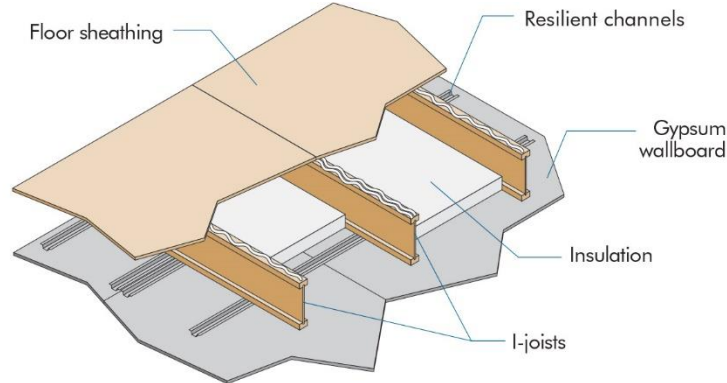

A. BASIC ASSEMBLIES

- 1) Floor Topping (Optional): Varies (reference sound ratings if applicable).
- 2) Floor Sheathing: Min. 23/32-inch (18-mm) T&G Wood Structural Panel. A construction adhesive must be applied to the top of the joists prior to placing sheathing. The sheets shall be installed with their long edge perpendicular to the joists with end joints centered over the top flange of joists. Floor sheathing must be installed per code requirements.
- 3) Insulation: Min. 3-1/2-inch (89-mm) Fiber Glass Insulation (R13). Installed adjacent to the bottom flange of the I-joist and supported by the resilient channels.
- 4) Structural Members: Min. 9-1/2-inch (241-mm) Deep I-Joists. Max. 24 inches (610 mm) on center spacing. Min. flange thickness of 1-1/2 inches (38 mm) and each flange area of at least 3.75 inches² (2,419 mm²). Min. web thickness of 3/8 inch (9.5 mm).
- 5) Resilient Channels: Min. 0.019-inch (0.5-mm) Galvanized Resilient Channels. Attached perpendicular to the bottom flange of the I-joist with 1-1/4-inch (32-mm) Type W drywall screws. Channels are spaced a max. of 16 inches (406 mm) on center, are doubled at each wallboard end joint, and extend to the next joist beyond each joint.
- 6) Ceiling: One layer of 3/4-inch (19-mm) Type X Gypsum Wallboard with a minimum weight of 3.0 lbf/ft² (14.6 kg/m²) in compliance with ASTM C1396. Installed with long dimension perpendicular to resilient channels and fastened with min. 1-1/8-inch (29-mm) Type S drywall screws spaced at 8 inches (203 mm) on center, and 1 inch (25 mm) from wallboard edges and 1-1/2 inches (38 mm) from wallboard ends. The end joints of the wallboard must be staggered.
 - a) Finish: The face joints must be covered with tape and coated with joint compound. Screw heads must also be covered with joint compound.

B. SOUND RATING^(a)

Components	STC	IIC
Base Assembly with cushioned vinyl	52	44
Base Assembly with Carpet and Padding	52	64
Base Assembly with cushioned vinyl, Gypsum Concrete	64	53
Base Assembly with Carpet and Padding, Gypsum Concrete	64	68

^(a) Sound ratings determined from engineering analysis using AWC Technical Report 15, Calculation of Sound Transmission Parameters for Wood-Frame Assemblies in accordance with Section 1206.2 of the 2024/2021/2018 IBC.

C. SIMILAR ASSEMBLIES

- 1) Assemblies that meet the fire-resistance rating in accordance with NBC Table 9.10.3.1.-B or the calculation method specified in NBC Appendix D-2.3.

* This assembly may also be used in a fire-rated roof/ceiling assembly, but only when constructed exactly as described.

† Authorization for use by APA – The Engineered Wood Association.

REPRESENTING THE ENGINEERED WOOD INDUSTRY



Tolko Industries, Ltd. Assembly TTI2.1

Two-Hour Fire Resistance Rated Floor/Ceiling Assembly*

This fire resistance design is listed in accordance with the International Building Code (IBC) and American Wood Council's Design for Code Acceptance (DCA) 3

Min. 9-1/4 inches (235 mm) Deep: TTI 400S, TTI 600S, TTI 800S, and TTI 900S I-Joists

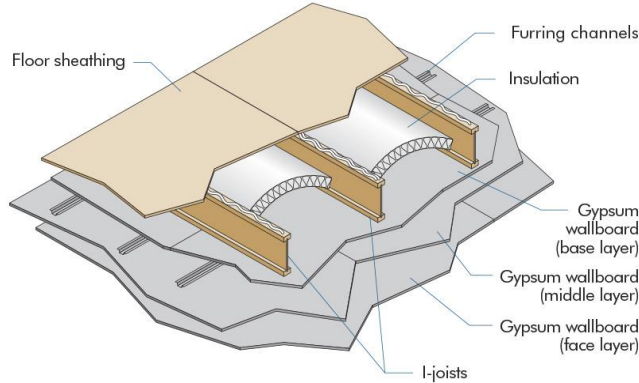

A. BASIC ASSEMBLIES

- 1) Floor Topping (Optional): Varies (reference sound ratings if applicable).
- 2) Floor Sheathing: Min. 23/32-inch (18-mm) T&G Wood Structural Panel. The sheets shall be installed with their long edge perpendicular to the joists with end joints centered over the top flange of joists. Floor sheathing must be installed per code requirements.
- 3) Insulation: 3-1/2-inch (89-mm) Unfaced Glass Fiber Insulation. Friction fitted between I-joists and supported by stay wires spaced 12 inches (305 mm) on center along the top of the I-joist bottom flange.
- 4) Structural Members: Min. 9-1/4 inches (235 mm) Deep I-Joists. Max. 24 inches (610 mm) on center spacing. Min. flange thickness of 1-1/2 inches (38 mm) and each flange area of at least 2.25 inches² (1,452 mm²). Min. web thickness of 3/8 inch (9.5 mm).
- 5) Furring Channels: Min. 0.0179-inch (0.45-mm) Hat Shaped Galvanized Steel Channels attached perpendicular to the bottom flange of the I-joist with 1-5/8-inch (41-mm) Type S drywall screws penetrating through the wallboard base layer into each I-joist flange. Channels are spaced a max. of 16 inches (406 mm) on center, are doubled at each base layer wallboard end joint, and extend to the next joist beyond each joint.
- 6) Ceiling: Three layers of 5/8-inch (16-mm) Type C Gypsum Wallboard.
 - a) Base Layer: Install with long dimension perpendicular to joist length. Attach to the bottom flange of the joists using 1-5/8-inch (41-mm) Type S drywall screws at 12 inches (305 mm) on center. The end joints of the wallboard must be centered on the bottom flange of the I-joist and must be staggered.
 - b) Middle Layer: Attached to furring channels using 1-inch (25-mm) Type S drywall screws at 12 inches (305 mm) on center with the long dimension perpendicular to furring channels. End joints must be staggered from end joints of adjacent sheets and end joints on the face layer.
 - c) Face Layer: Attached to furring channels through the middle layer using 1-5/8-inch (41-mm) Type S drywall screws spaced at 8 inches (203 mm) on center with long dimension perpendicular to furring channel. End joints must be staggered from end joints of adjacent sheets and staggered from end joints on the middle layer. Edge joints (long dimension) must be offset 24 inches (610 mm) from those of the middle layer.
 - d) Finish: The face layer joints must be covered with tape and coated with joint compound. Screw heads must also be covered with joint compound.

B. SOUND RATING (with Resilient Channels)^(a,b)

Joist/RC Spacing	Without Gypsum Concrete				With 1-in. (25-mm) Gypsum Concrete			
	Cushioned Vinyl		Carpet & Pad		Cushioned Vinyl		Carpet & Pad	
	STC	IIC	STC	IIC	STC	IIC	STC	IIC
24"/16" o.c.	--	--	49	54	58	45	58	64

^(c) Sound ratings from the American Wood Council publication Design for Code Acceptance (DCA) 3, available from www.awc.org.

^(d) STC and IIC values are based on engineering analysis performed by David L. Adams Associates, Inc.

C. SIMILAR ASSEMBLIES

- 1) 2015/2018/2021/2024 IBC Table 721.1(3) Item 28-1.1 and DCA 3 WIJ-2.1.
- 2) Assemblies that meet the fire-resistance rating in accordance with NBC Table 9.10.3.1.-B or the calculation method specified in NBC Appendix D-2.3.

* This assembly may also be used in a fire-rated roof/ceiling assembly, but only when constructed exactly as described.

REPRESENTING THE ENGINEERED WOOD INDUSTRY

APA – The Engineered Wood Association is an approved national standards developer accredited by American National Standards Institute (ANSI). APA publishes ANSI standards and Voluntary Product Standards for wood structural panels and engineered wood products. APA is an accredited certification body under ISO/IEC 17065 by Standards Council of Canada (SCC), an accredited inspection agency under ISO/IEC 17020 by ANSI National Accreditation Board (ANAB), and an accredited testing organization under ISO/IEC 17025 by ANAB. APA is also an approved Product Certification Agency, Testing Laboratory, Quality Assurance Entity, Validation Entity, and Product Evaluation Agency by the State of Florida, and an approved testing laboratory by City of Los Angeles.

**APA – THE ENGINEERED WOOD ASSOCIATION
HEADQUARTERS**

7011 So. 19th St. ▪ Tacoma, Washington 98466
Phone: (253) 565-6600 ▪ Fax: (253) 565-7265 ▪ Internet Address: www.apawood.org

PRODUCT SUPPORT HELP DESK
(253) 620-7400 ▪ *E-mail Address:* help@apawood.org

DISCLAIMER

APA Product Report® is a trademark of *APA – The Engineered Wood Association*, Tacoma, Washington. The information contained herein is based on the product evaluation in accordance with the references noted in this report. No warranties, express or implied, including as to fitness for a particular purpose, are made regarding this report. Neither APA nor its members shall be liable, or assume any legal liability or responsibility, for damages, direct or indirect, arising from the use, application of, and/or reference to opinions, findings, conclusions or recommendations included in this report. Consult your local jurisdiction or design professional to assure compliance with code, construction, and performance requirements. Because APA has no control over quality of workmanship or the conditions under which engineered wood products are used, it cannot accept responsibility for product performance or designs as actually constructed.