



## Fire-Rated Assemblies Nordic Structures

PR-S274

Revised September 3, 2024

Products: Nordic Joist™ Series Prefabricated Wood I-Joists  
Nordic Structures, 1100 Avenue des Canadiens-de-Montréal, Suite 100, Montreal, Québec,  
Canada H3B 2S2  
(514) 871-8526  
[www.nordic.ca](http://www.nordic.ca)

1. Basis of the product report:
  - 2024 International Building Code (IBC): Sections 104.2.3 Alternative material, 703 Fire-Resistance Ratings and Fire Tests, 721 Prescriptive Fire Resistance, 722.6 Wood assemblies, and 2303.1.2 Prefabricated wood I-joists.
  - 2021, 2018, 2015 IBC: Sections 104.11 Alternative materials, 703 Fire-Resistance Ratings and Fire Tests, 721 Prescriptive Fire Resistance, 722.6 Wood assemblies, and 2303.1.2 Prefabricated wood I-joists
  - 2024 International Residential Code (IRC): Sections R104.2.2 Alternative materials, R302.13 Fire protection of floors, and R502.1.2 and R802.1.7 Prefabricated wood I-joists.
  - 2021, 2018, and 2015 IRC: Sections R104.11 Alternative materials, R302.13 Fire protection of floors, R502.1.2 and R802.1.8 (2021 and 2018 IRC only) Prefabricated wood I-joists.
  - 2020 National Building Code of Canada (NBC): Clause 1.2.1.1 of Division A, Clauses 3.1.7, 4.1, 4.3.1.1, 9.10.3.1, 9.11, and 9.23.4.2 of Division B, Table 9.10.3.1.-B, and Appendix D
  - ASTM D5055-19e1, D5055-16, D5055-13e1, and D5055-13, recognized by the 2024 IBC and IRC, 2021 IBC and IRC, 2018 IBC and IRC, and 2015 IBC and IRC, respectively
  - American Wood Council Design for Code Acceptance DCA 3, Fire-Rated Wood-Frame Wall and Floor/Ceiling Assemblies
  - APA System Report SR-405
  - ICC-ES ESR-1742 and ESR-1405
  - CCMC 13032-R
  - APA Product Reports PR-L274 and PR-L274(C)
  - ASTM E119 and CAN/ULC S101 full-scale fire test reports, and engineering analyses
2. Product description:

Nordic Joist™ Series I-joists covered in this report, as described in Table 1, are made with lumber flanges and oriented strand board (OSB) webs in accordance with the in-plant manufacturing standard approved by APA, as documented in ICC-ES ESR-1742 and APA PR-L274 in the U.S., and CCMC 13032-R and APA PR-L274(C) in Canada.
3. Design properties:

Design properties for Nordic Joist Series I-joists are provided in ICC-ES ESR-1742 and APA PR-L274 in the U.S., and CCMC 13032-R and APA PR-L274(C) in Canada.
4. Product installation:

Nordic Joist Series I-joists covered in this report shall be installed in accordance with the recommendations provided by the manufacturer ([www.nordic.ca](http://www.nordic.ca)).
5. Fire-rated assemblies:

Nordic Joist Series I-joists have been shown through testing and engineering analysis to achieve the fire resistance ratings described in this report. Fire-rated assemblies for Nordic Joist Series I-joists shall be constructed in accordance with the prescriptive requirements provided in this report or recommended by the manufacturer (see link above). In addition, Nordic Joist Series I-joists shall be permitted for use in the fire-rated assemblies described in Section 4.2.2.2 (Assembly 2) of ICC-ES ESR-1405, and Nordic Joist Series I-joists with a

minimum depth of 9-1/2 inches shall be permitted for use in the fire-rated assemblies described in Sections 4.2.2.3 (Assembly 3) and 4.2.2.1 (Assembly 1) of ICC-ES ESR-1405, when installed in accordance with the requirements specified therein. For rim board products installed along with Nordic Joist Series I-joists, the fire-rated rim board assemblies are available from the rim board manufacturer's literature or APA Data File: *APA Rim Board® in Fire-Rated Assemblies*, Form D350 ([www.apawood.org/resource-library](http://www.apawood.org/resource-library)).

6. Fire-protection of floors:  
Nordic Joist Series I-joists as described in Table 2, when installed and protected as specified in APA System Report SR-405 (see link above) or FP-11 provided in this report, meet the requirements of the 2024, 2021, 2018, and 2015 IRC Section R302.13, or are alternatives to the 2-by-10 dimension lumber prescribed in Exception 4 to the 2024, 2021, 2018, and 2015 IRC Section R302.13 with demonstrated equivalent fire performance.
7. Limitations:
  - a) Nordic Joist Series I-joists covered in this report shall be designed in accordance with the code using the design properties specified in ICC-ES ESR-1742 and APA PR-L274 in the U.S., and CCMC 13032-R and APA PR-L274(C) in Canada.
  - b) Nordic Joist Series I-joists covered in this report are limited to dry service conditions where the average equilibrium moisture content of sawn lumber is less than 16% in the U.S. and the average equilibrium moisture content of solid-sawn lumber over a year is 15% or less and does not exceed 19% in Canada.
  - c) Nordic Joist Series I-joists covered in this report are permitted for use in fire-rated assemblies that meet the fire-resistance rating in accordance with the calculation method specified in NBC Appendix D-2.3.
  - d) Nordic Joist Series I-joists covered in this report are produced at the Nordic Structures facility in Chibougamau, Québec under a quality assurance program audited by APA.
  - e) This report is subject to re-examination in one year.
8. Identification:  
Nordic Joist Series I-joists described in this report are identified by a label bearing the manufacturer's name (Nordic Structures) and/or trademark, the APA assigned plant number (1052), the I-joist series, the APA logo, and a means of identifying the date of manufacture.

Table 1. Description of Nordic Joist Series I-Joists<sup>(a)</sup>

Joist Series	Joist Depths (in.)	Flanges				Web	
		Material	G <sup>(b)</sup>	Dimension		Material	Thickness (in.)
				Depth (in.)	Width (in.)		
NI-20	9-1/4 - 11-7/8	Proprietary SPF	0.42	1-1/2	2-1/2	OSB	3/8
NI-40	9-1/2 - 16	Proprietary SPF	0.42	1-1/2	2-1/2	OSB	3/8
NI-40x	7-7/8 - 16	Proprietary SPF	0.42	1-1/2	2-1/2	OSB	3/8
NI-60	7-7/8 - 18	MSR SPF	0.46	1-1/2	2-1/2	OSB	3/8
NI-70	9-1/2 - 16	MSR SPF	0.46	1-1/2	3-1/2	OSB	3/8
NI-80	7-7/8 - 16	MSR SPF	0.46	1-1/2	3-1/2	OSB	3/8
NI-80x	18 - 24	MSR SPF	0.46	1-1/2	3-1/2	OSB	7/16
NI-90	11-7/8 - 16	Proprietary SPF	0.50	1-1/2	3-1/2	OSB	7/16
NI-90x	11-7/8 - 16	Proprietary SPF	0.42	2	3-1/2	OSB	7/16

<sup>(a)</sup> Referenced dimensions are nominal. Tolerances are as specified in the in-plant quality manual.

<sup>(b)</sup> Specific gravity of flanges for use in diaphragm design based on oven-dry weight and oven-dry volume.

Table 2. Applicable Nordic Joist Series I-Joists that comply with APA System Report SR-405

Assembly in SR-405	Applicable Joist Series
FP-01	NI-20, NI-40, NI-40x, NI-60, NI-70, NI-80, NI-80x, NI-90, and NI-90x
FP-02 <sup>(a)</sup>	NI-20, NI-40, NI-40x, NI-60, NI-70, NI-80, NI-80x, NI-90, and NI-90x
FP-03 <sup>(a)</sup>	NI-20, NI-40, NI-40x, NI-60, NI-70, NI-80, NI-80x, NI-90, and NI-90x
FP-04 <sup>(a)</sup>	NI-20, NI-40, NI-40x, NI-60, NI-70, NI-80, NI-80x, NI-90, and NI-90x
FP-06 <sup>(a)</sup>	NI-20, NI-40, NI-40x, NI-60, NI-70, NI-80, NI-80x, NI-90, and NI-90x
FP-07 <sup>(a)</sup>	NI-20, NI-40, NI-40x, NI-60, NI-70, NI-80, NI-80x, NI-90, and NI-90x
FP-09 <sup>(a)</sup>	NI-20, NI-40, NI-40x, NI-60, NI-70, NI-80, NI-80x, NI-90, and NI-90x
FP-11 <sup>(a,b)</sup>	NI-20, NI-40, NI-40x, NI-60, NI-70, NI-80, NI-80x, NI-90, and NI-90x
FP-12 <sup>(a)</sup>	NI-20, NI-40, NI-40x, NI-60, NI-70, NI-80, NI-80x, NI-90, and NI-90x

<sup>(a)</sup> Minimum joist depth of 9-1/2 inches.

<sup>(b)</sup> Assembly shown in this report, but outside of SR-405.



## Nordic Structures Assembly NEW.P45.1

### 45-Minute Fire Resistance Rated Floor/Ceiling Assembly

This fire resistance design is listed in accordance with ASTM E119 and CAN/ULC S101

**Min. 9-1/4 inches (235 mm) Deep: NI-20, NI-40, NI-40x, NI-60, NI-70, NI-80, NI-80x, NI-90, and NI-90x I-Joists**

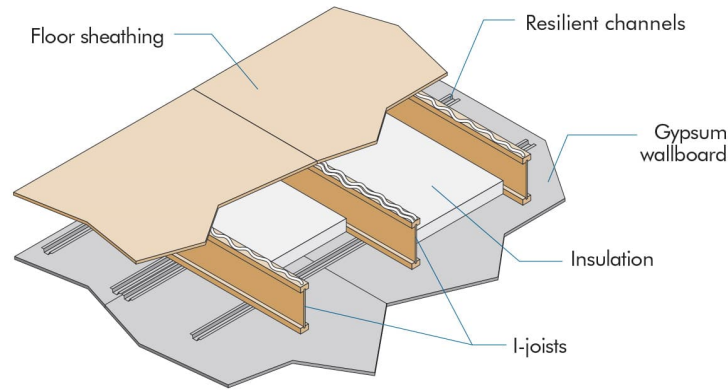

#### A. BASIC ASSEMBLIES

- 1) Floor Topping (Optional): Varies.
- 2) Floor Sheathing: Min. 5/8-inch (16-mm) T&G Wood Structural Panel when topping is used and the joist spacing is 19.2 inches (488 mm) or less. Otherwise, min. 3/4-inch (19-mm) T&G Wood Structural Panel must be used. The sheets shall be installed with their long edge perpendicular to I-joists with end joints centered over the top flange of I-joists and staggered. Floor sheathing must be installed per code requirements.
- 3) Insulation (Optional): 3-1/2-inch (89-mm) Glass Fiber Insulation Batts installed over joist flanges or min. 2-inch (51-mm) Mineral Wool Insulation Batts (nominal 2.5 pcf) friction fit between I-joist flanges.
- 4) Structural Members: Min. 9-1/4 inches (235 mm) Deep I-Joists. Max. 24 inches (610 mm) on center spacing. Min. flange dimensions of 1-1/2 inches (38 mm) thick by 2-1/2 inches (64 mm) wide. Min. web thickness of 3/8 inch (9.5 mm).
- 5) Resilient Channels: Min. 25 Gauge Galvanized Resilient Channels. Attached perpendicular to the bottom flange of the I-joist with 1-5/8-inch (41-mm) Type W drywall screws. Channels are spaced a max. of 16 inches (406 mm) on center, are doubled at each base layer wallboard end joint, and extend to the next joist beyond each joint.
- 6) Ceiling: One layer of 5/8-inch (16-mm) Type C Gypsum Wallboard. Installed with long dimension perpendicular to resilient channels and fastened with min. 1-1/8-inch (29-mm) Type S drywall screws spaced at 7 inches (178 mm) on center. The end joints of the wallboard must be staggered the equivalent of two joist spacings with those of adjacent sheets. Screws shall be min. 1-1/2 inches (38 mm) from board edges and 3/4 inch (19 mm) from board ends.
  - a) Finish: The face layer joints must be covered with tape and coated with joint compound. Screw heads must also be covered with joint compound.

#### B. SOUND RATINGS

Information not available

#### C. SIMILAR ASSEMBLIES

- 1) Intertek Listing NEW/FCA 45-01, and 2020 NBC Table 9.10.3.1.-B Assemblies F5, F8, F10, F14, and F20.
- 2) Assemblies that meet the fire-resistance rating in accordance with the calculation method specified in NBC Appendix D-2.3.

*REPRESENTING THE ENGINEERED WOOD INDUSTRY*



## Nordic Structures Assembly NEW.P60.1

### One-Hour Fire Resistance Rated Floor/Ceiling Assembly

This fire resistance design is listed in accordance with the ASTM E119 and CAN/ULC S101

**Min. 9-1/4 inches (235 mm) Deep: NI-70, NI-80, NI-80x, NI-90, and NI-90x I-Joists**

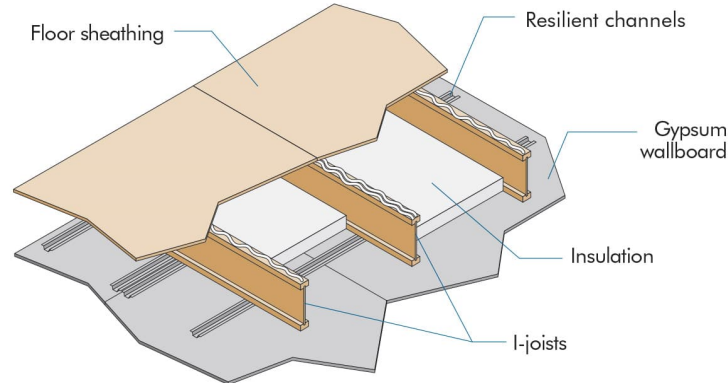

#### A. BASIC ASSEMBLIES

- 1) Floor Topping (Optional): Varies.
- 2) Floor Sheathing: Min. 5/8-inch (16-mm) T&G Wood Structural Panel when topping is used and the joist spacing is 19.2 inches (488 mm) or less. Otherwise, min. 23/32-inch (18-mm) T&G Wood Structural Panel must be used. The sheets shall be installed with their long edge perpendicular to I-joists with end joints centered over the top flange of I-joists and staggered. Floor sheathing must be installed per code requirements.
- 3) Insulation: Min. 1-1/2-inch (38-mm) Mineral Wool Insulation Batts (nominal 2.5 pcf) friction fit between I-joist flanges.
- 4) Structural Members: Min. 9-1/4 inches (235 mm) Deep I-Joists. Max. 24 inches (610 mm) on center spacing. Min. flange dimensions of 1-1/2 inches (38 mm) thick by 3-1/2 inches (89 mm) wide. Min. web thickness of 3/8 inch (9.5 mm).
- 5) Resilient Channels: Min. 25 Gauge Galvanized Resilient Channels. Attached perpendicular to the bottom flange of the I-joist with 1-5/8-inch (41-mm) Type W drywall screws. Channels are spaced a max. of 16 inches (406 mm) on center, are doubled at each base layer wallboard end joint, and extend to the next joist beyond each joint.
- 6) Ceiling: One layer of 5/8-inch (16-mm) Type C Gypsum Wallboard. Installed with long dimension perpendicular to resilient channels and fastened with min. 1-1/8-inch (29-mm) Type S drywall screws spaced at 7 inches (178 mm) on center. The end joints of the wallboard must be staggered 48 inches (1219 mm) with those of adjacent sheets. Screws shall be min. 1-1/2 inches (38 mm) from board edges and 3/4 inch (19 mm) from board ends.
  - a) Finish: The face layer joints must be covered with tape and coated with joint compound. Screw heads must also be covered with joint compound.

#### B. SOUND RATINGS

Information not available

#### C. SIMILAR ASSEMBLIES

- 1) Intertek Listing NEW/FCA 60-01, and 2020 NBC Table 9.10.3.1.-B Assemblies F8, F10, F14, and F20.
- 2) Assemblies that meet the fire-resistance rating in accordance with the calculation method specified in NBC Appendix D-2.3.

*REPRESENTING THE ENGINEERED WOOD INDUSTRY*



## Nordic Structures Assembly NEW.P60.2

### One-Hour Fire Resistance Rated Floor/Ceiling Assembly

This fire resistance design is listed in accordance with the ASTM E119 and CAN/ULC S101

**Min. 9-1/4 inches (235 mm) Deep: NI-20, NI-40, NI-40x, NI-60, NI-70, NI-80, NI-80x, NI-90, and NI-90x I-Joists**

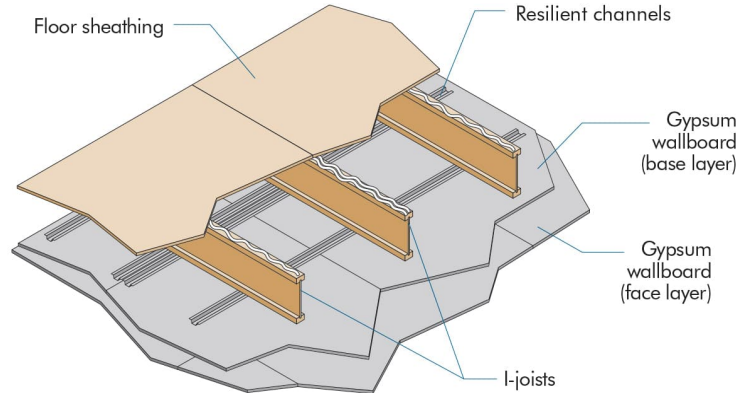

#### A. BASIC ASSEMBLIES

- 1) Floor Topping (Optional): Varies.
- 2) Floor Sheathing: Min. 5/8-inch (16-mm) T&G Wood Structural Panel when topping is used and the joist spacing is 19.2 inches (488 mm) or less. Otherwise, min. 3/4-inch (19-mm) T&G Wood Structural Panel must be used. A construction adhesive must be applied to the top of the joists prior to placing sheathing. The sheets shall be installed with their long edge perpendicular to I-joists with end joints centered over the top flange of I-joists and staggered. Floor sheathing must be installed per code requirements.
- 3) Insulation (Optional): Min. 3-1/2-inch (89-mm) Glass Fiber Insulation or Mineral Wool Insulation Batts friction fit between I-joint flanges except that when ceiling membrane is 5/8-inch (16-mm) Type C gypsum wallboard, the insulation thickness is not limited, but must be friction fit between I-joint flanges and webs.
- 4) Structural Members: Min. 9-1/4 inches (235 mm) Deep I-Joists. Max. 24 inches (610 mm) on center spacing. Min. flange dimensions of 1-1/2 inches (38 mm) thick by 2-1/2 inches (64 mm) wide. Min. web thickness of 3/8 inch (9.5 mm).
- 5) Resilient Channels: Min. 25 Gauge Galvanized Resilient Channels. Attached perpendicular to the bottom flange of the I-joint with 1-5/8-inch (41-mm) Type W drywall screws. Channels are spaced a max. of 16 inches (406 mm) on center, are doubled at each base layer wallboard end joint, and extend to the next joist beyond each joint.
- 6) Ceiling: Two layers of 1/2-inch (13-mm) Type X Gypsum Wallboard.
  - a) Base Layer: Install with long dimension perpendicular to resilient channels. Attach to the resilient channels using 1-1/8-inch (29-mm) Type S drywall screws at 12 inches (305 mm) on center. The end joints of the wallboard must be staggered a min. of 24 inches (610 mm).
  - b) Face Layer: Install with long dimension perpendicular to resilient channels. Attach to the resilient channels through the base layer using 1-5/8-inch (41-mm) Type S drywall screws spaced at 12 inches (305 mm) on center at intermediate supports and 1-1/2-inch (38-mm) Type W drywall screws spaced at 8 inches (203 mm) on center at end joints. Edge joints (long dimension) must be offset 24 inches (610 mm) from those of the base layer.
  - c) Finish: The face layer joints must be covered with tape and coated with joint compound. Screw heads must also be covered with joint compound.

#### B. SOUND RATINGS

Information not available

#### C. SIMILAR ASSEMBLIES

- 1) Intertek Listing NEW/FCA 60-02, and 2020 NBC Table 9.10.3.1.-B Assemblies F6, F9, F11, F15, F19, and F21.
- 2) Assemblies that meet the fire-resistance rating in accordance with the calculation method specified in NBC Appendix D-2.3.

*REPRESENTING THE ENGINEERED WOOD INDUSTRY*



## Nordic Structures Assembly NEW.P60.3

### One-Hour Fire Resistance Rated Floor/Ceiling Assembly

This fire resistance design is listed in accordance with the ASTM E119 and CAN/ULC S101

**Min. 9-1/4 inches (235 mm) Deep: NI-20, NI-40, NI-40x, NI-60, NI-70, NI-80, NI-80x, NI-90, and NI-90x I-Joists**

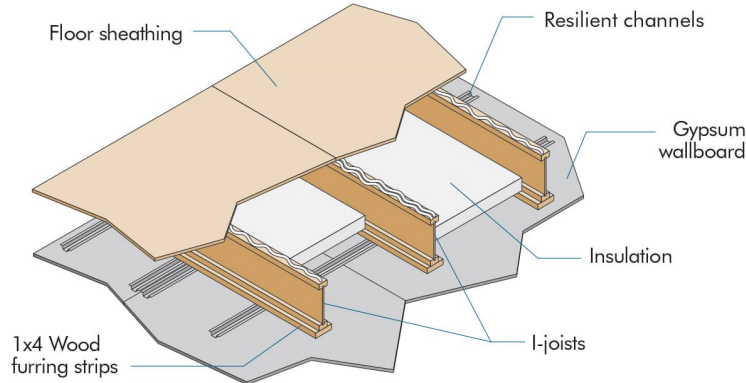

#### A. BASIC ASSEMBLIES

- 1) Floor Topping (Optional): Varies.
- 2) Floor Sheathing: Min. 5/8-inch (16-mm) T&G Wood Structural Panel when topping is used and the joist spacing is 19.2 inches (488 mm) or less. Otherwise, min. 3/4-inch (19-mm) T&G Wood Structural Panel must be used. A construction adhesive must be applied to the top of the joists prior to placing sheathing. The sheets shall be installed with their long edge perpendicular to I-joists with end joints centered over the top flange of I-joists and staggered. Floor sheathing must be installed per code requirements.
- 3) Insulation: Min. 2-inch (51-mm) Mineral Wool Insulation Batts (nominal 3.5 pcf) friction fit between I-joist webs, resting on wood furring strips.
- 4) Structural Members: Min. 9-1/4 inches (235 mm) Deep I-Joists. Max. 24 inches (610 mm) on center spacing. Min. flange dimensions of 1-1/2 inches (38 mm) thick by 2-1/2 inches (64 mm) wide. Min. web thickness of 3/8 inch (9.5 mm).
- 5) Wood Furring Strips: Min. nominal 1 inch (25 mm) x 4 inches (102 mm) attached with 1-1/4-inch (32-mm) Type W drywall screws at 24 inches (610 mm) on center along the bottom of the bottom flange of each I-joist.
- 6) Resilient Channels: Min. 24 Gauge Galvanized Resilient Channels. Attached perpendicular to the bottom flange of the I-joist with 1-5/8-inch (41-mm) Type W drywall screws. Channels are spaced a max. of 16 inches (406 mm) on center, are doubled at each base layer wallboard end joint, and extend to the next joist beyond each joint.
- 7) Ceiling: One layer of 5/8-inch (16-mm) Type C Gypsum Wallboard. Installed with long dimension perpendicular to resilient channels and fastened with min. 1-1/8-inch (29-mm) Type S drywall screws spaced at 7 inches (178 mm) on center. The end joints of the wallboard must be staggered 48 inches (1219 mm) with those of adjacent sheets. Screws shall be min. 1-1/2 inches (38 mm) from board edges and 3/4 inch (19 mm) from board ends.
  - a) Finish: The face layer joints must be covered with tape and coated with joint compound. Screw heads must also be covered with joint compound.

#### B. SOUND RATINGS

Information not available

#### C. SIMILAR ASSEMBLIES

- 1) Intertek Listing NEW/FCA 60-03, and 2020 NBC Table 9.10.3.1.-B Assemblies F8, F10, F14, and F20.
- 2) Assemblies that meet the fire-resistance rating in accordance with the calculation method specified in NBC Appendix D-2.3.

*REPRESENTING THE ENGINEERED WOOD INDUSTRY*



## Nordic Structures Assembly NEW.P60.4

### One-Hour Fire Resistance Rated Roof/Ceiling Assembly

This fire resistance design is listed in accordance with the ASTM E119 and CAN/ULC S101

**Min. 9-1/4 inches (235 mm) Deep: NI-70, NI-80, NI-80x, NI-90, and NI-90 I-Joists**

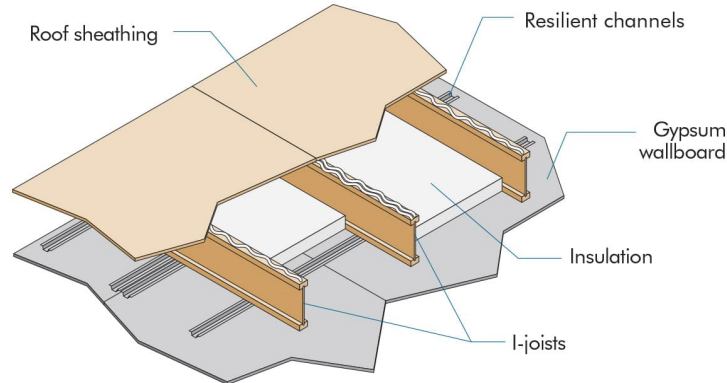

#### A. BASIC ASSEMBLIES

- 1) Roof Covering System: Insulation and roof covering materials intended for built-up covering that provides Class A, B, or C covering on combustible wood deck for fire resistant assemblies equivalent to this assembly.
- 2) Roof Sheathing: Min. 1/2-inch (13-mm) Wood Structural Panel. The sheets shall be installed with their long edge perpendicular to I-joists with end joints centered over the top flange of I-joists and staggered. Roof sheathing must be installed per code requirements.
- 3) Insulation: Min. 1-1/2-inch (38-mm) Mineral Wool Insulation Batts (nominal 2.5 pcf) friction fit between I-joist flanges.
- 4) Structural Members: Min. 9-1/4 inches (235 mm) Deep I-Joists. Max. 24 inches (610 mm) on center spacing. Min. flange dimensions of 1-1/2 inches (38 mm) thick by 3-1/2 inches (89 mm) wide. Min. web thickness of 3/8 inch (9.5 mm).
- 5) Resilient Channels: Min. 25 Gauge Galvanized Resilient Channels. Attached perpendicular to the bottom flange of the I-joist with 1-5/8-inch (41-mm) Type W drywall screws. Channels are spaced a max. of 16 inches (406 mm) on center, are doubled at each base layer wallboard end joint, and extend to the next joist beyond each joint.
- 6) Ceiling: One layer of 5/8-inch (16-mm) Type C Gypsum Wallboard. Installed with long dimension perpendicular to resilient channels and fastened with min. 1-1/8-inch (29-mm) Type S drywall screws spaced at 7 inches (178 mm) on center. The end joints of the wallboard must be staggered 48 inches (1219 mm) with those of adjacent sheets. Screws shall be min. 1-1/2 inches (38 mm) from board edges and 3/4 inch (19 mm) from board ends.
  - a) Finish: The face layer joints must be covered with tape and coated with joint compound. Screw heads must also be covered with joint compound.

#### B. SOUND RATINGS

Information not available

#### C. SIMILAR ASSEMBLIES

- 1) Intertek Listing NEW/RCA 60-01, and 2020 NBC Table 9.10.3.1.-B Assemblies F8, F10, F14, and F20.
- 2) Assemblies that meet the fire-resistance rating in accordance with the calculation method specified in NBC Appendix D-2.3.

*REPRESENTING THE ENGINEERED WOOD INDUSTRY*





## Nordic Structures Assembly NEW.P120.1

### Two-Hour Fire Resistance Rated Floor/Ceiling Assembly

This fire resistance design is listed in accordance with the ASTM E119 and CAN/ULC S101

**Min. 9-1/4 inches (235 mm) Deep: NI-20, NI-40, NI-40x, NI-60, NI-70, NI-80, NI-80x, NI-90, and NI-90x I-Joists**

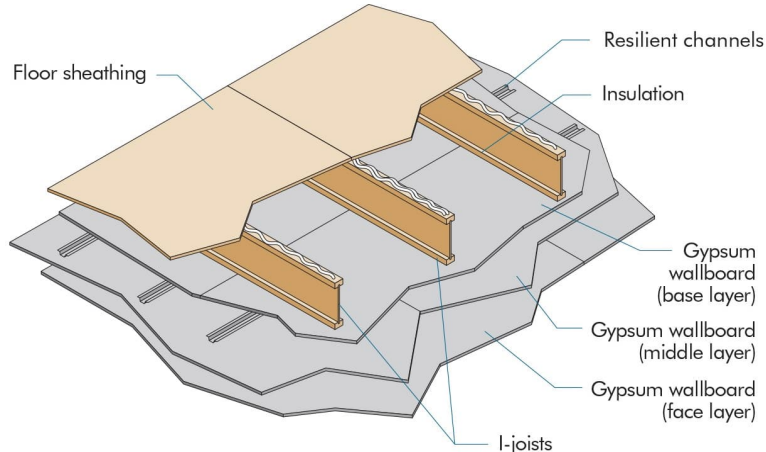

#### A. BASIC ASSEMBLIES

- 1) Floor Topping (Optional): Varies.
- 2) Floor Sheathing: Min. 5/8-inch (16-mm) T&G Wood Structural Panel when topping is used and the joist spacing is 19.2 inches (488 mm) or less. Otherwise, min. 23/32-inch (18-mm) T&G Wood Structural Panel must be used. The sheets shall be installed with their long edge perpendicular to I-joists with end joints centered over the top flange of I-joists and staggered. Floor sheathing must be installed per code requirements.
- 3) Insulation (Optional): Max. 6-inch (152-mm) Glass Fiber Insulation or Mineral Wool Insulation Batts friction fit between I-joist webs and supported by stay wires at 16 inches (406 mm) on center.
- 4) Structural Members: Min. 9-1/4 inches (235 mm) Deep I-Joists. Max. 24 inches (610 mm) on center spacing. Min. flange dimensions of 1-1/2 inches (38 mm) thick by 2-1/2 inches (64 mm) wide. Min. web thickness of 3/8 inch (9.5 mm).
- 5) Resilient Channels: Min. 25 Gauge Galvanized Resilient Channels. Attached perpendicular to the bottom flange of the I-joist with 1-5/8-inch (41-mm) Type S drywall screws. Channels are spaced a max. of 16 inches (406 mm) on center, are doubled at each base layer wallboard end joint, and extend to the next joist beyond each joint.
- 6) Ceiling: Three layers of 5/8-inch (16-mm) Type C Gypsum Wallboard.
  - a) Base Layer: Install with long dimension perpendicular to joist length. Attach to the bottom flange of the joists using 1-5/8-inch (41-mm) Type S drywall screws at 12 inches (305 mm) on center. The end joints of the wallboard must be centered on the bottom flange of the I-joist and must be staggered a min. of 24 inches (610 mm).
  - b) Middle Layer: Attached to resilient channels using 1-inch (25-mm) Type S drywall screws at 12 inches (305 mm) on center with the long dimension perpendicular to resilient channels. End joints must be staggered a min. of 24 inches (610 mm) from end joints of adjacent sheets and end joints on the face layer.
  - c) Face Layer: Attached to resilient channels through the middle layer using 1-5/8-inch (41-mm) Type S drywall screws spaced at 8 inches (203 mm) on center with long dimension perpendicular to resilient channel. End joints must be staggered from end joints of adjacent sheets and staggered from end joints on the middle layer. Edge joints (long dimension) must be offset 24 inches (610 mm) from those of the middle layer.
  - d) Finish: The face layer joints must be covered with tape and coated with joint compound. Screw heads must also be covered with joint compound.

#### B. SOUND RATINGS

Information not available

#### C. SIMILAR ASSEMBLIES

- 1) Intertek Listing NEW/FCA 120-01.
- 2) Assemblies that meet the fire-resistance rating in accordance with NBC Table 9.10.3.1.-B or the calculation method specified in NBC Appendix D-2.3.

*REPRESENTING THE ENGINEERED WOOD INDUSTRY*



**Nordic Structures Assembly NEW1.1**  
**One-Hour Fire Resistance Rated Floor/Ceiling Assembly\***  
 This fire resistance design is listed in accordance with the International Building Code (IBC) and  
*American Wood Council's Design for Code Acceptance (DCA) 3*  
**Min. 9-1/4 inches (235 mm) Deep: NI-70, NI-80, NI-80x, NI-90, and NI-90x I-Joists**

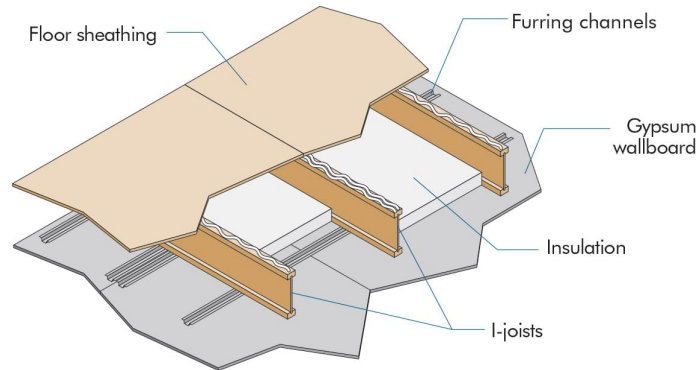

**A. BASIC ASSEMBLIES**

- 1) Floor Topping (Optional): Varies (reference sound ratings if applicable).
- 2) Floor Sheathing: Min. 23/32-inch (18-mm) T&G Wood Structural Panel. A construction adhesive must be applied to the top of the joists prior to placing sheathing. The sheets shall be installed with their long edge perpendicular to the joists with end joints centered over the top flange of joists. Floor sheathing must be installed per code requirements.
- 3) Insulation: Min. 1-1/2-inch (38-mm) Mineral Wool Insulation Batts (min. 2.5 pcf). Installed adjacent to the bottom flange of the I-joist and supported by the furring channels. Ends of batts shall be centered over furring channels.
- 4) Structural Members: Min. 9-1/4 inches (235 mm) Deep I-Joists. Max. 24 inch (610 mm) on center spacing. Min. flange thickness of 1-1/2 inches (38 mm) and each flange area of at least 5.25 inches<sup>2</sup> (3,387 mm<sup>2</sup>). Min. web thickness of 3/8 inch (9.5 mm).
- 5) Furring Channels: Min. 0.026-inch (0.66-mm) Hat Shaped Galvanized Steel Channels attached perpendicular to the bottom flange of the I-joist with 1-5/8-inch (41-mm) Type S drywall screws. Channels are spaced a max. of 16 inches (406 mm) on center, are doubled at each wallboard end joint, and extend to the next joist beyond each joint.
- 6) Ceiling: One layer of 5/8-inch (16-mm) Type C Gypsum Wallboard. Installed with long dimension perpendicular to furring channels and fastened with min. 1-1/8-inch (29-mm) Type S drywall screws spaced at 12 inches (305 mm) on center on intermediate joists and 8 inches (203 mm) on center at end joints, and 3/4 inch (19 mm) from wallboard edges and ends. The end joints of the wallboard must be staggered.
  - a) Finish: The face layer joints must be covered with tape and coated with joint compound. Screw heads must also be covered with joint compound.

**B. SOUND RATING (with Resilient Channels)<sup>(a,b)</sup>**

Joist/RC Spacing <sup>(c)</sup>	Without Gypsum Concrete				With 1-in. (25-mm) Gypsum Concrete			
	Cushioned Vinyl		Carpet & Pad		Cushioned Vinyl		Carpet & Pad	
	STC	IIC	STC	IIC	STC	IIC	STC	IIC
24"/16" o.c.	48 (51)	42 (43)	48 (51)	61 (63)	63 (65)	50 (52)	63 (65)	65 (67)
16"/16" o.c.	44 (46)	37 (39)	44 (46)	60 (61)	56 (57)	46 (47)	56 (57)	58 (59)

<sup>(a)</sup> Sound ratings from the American Wood Council publication Design for Code Acceptance (DCA) 3, available from [www.awc.org](http://www.awc.org).

<sup>(b)</sup> STC and IIC values established by engineering analysis based on 1.5-in. (38-mm) thick mineral wool batt insulation. Values in parentheses are based on 3.5-in. (89-mm) thick mineral wool batt insulation.

<sup>(c)</sup> STC and IIC values for 16 in. (406 mm) o.c. joist spacing are applicable to 19.2-in. (488 mm) o.c. joist spacing.

**C. SIMILAR ASSEMBLIES**

- 1) 2015/2018/2021/2024 IBC Table 721.1(3) Item 24-1.1, and DCA 3 WIJ-1.1.
- 2) Assemblies that meet the fire-resistance rating in accordance with NBC Table 9.10.3.1.-B or the calculation method specified in NBC Appendix D-2.3.

\* This assembly may also be used in a fire-rated roof/ceiling assembly, but only when constructed exactly as described.



**Nordic Structures Assembly NEW1.2**  
**One-Hour Fire Resistance Rated Floor/Ceiling Assembly\***  
 This fire resistance design is listed in accordance with the International Building Code (IBC) and  
*American Wood Council's Design for Code Acceptance (DCA) 3*  
**NI-80x, NI-90, and NI-90x I-Joists**

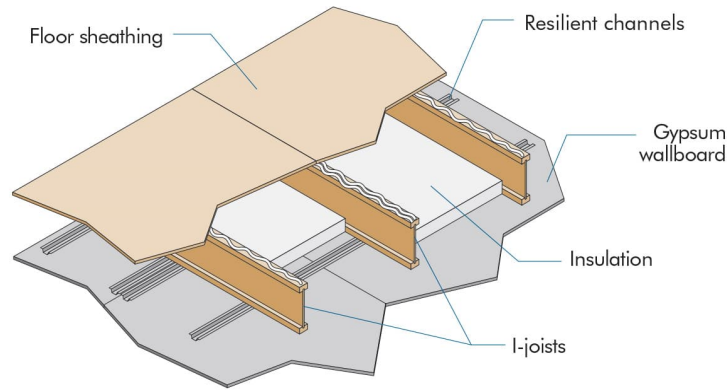

**A. BASIC ASSEMBLIES**

- 1) Floor Topping (Optional): Varies (reference sound ratings if applicable).
- 2) Floor Sheathing: Min. 23/32-inch (18-mm) T&G Wood Structural Panel. A construction adhesive must be applied to the top of the joists prior to placing sheathing. The sheets shall be installed with their long edge perpendicular to the joists with end joints centered over the top flange of joists. Floor sheathing must be installed per code requirements.
- 3) Insulation: Min. 1-1/2-inch (38-mm) Mineral Wool Insulation Batts (min. 2.5 pcf). Installed adjacent to the bottom flange of the I-joist and supported by the resilient channels. The ends of the batts shall be centered over resilient channels.
- 4) Structural Members: Min. 9-1/4 inches (235 mm) Deep I-Joists. Max. 24 inches (610 mm) on center spacing. Min. flange thickness of 1-1/2 inches (38 mm) and each flange area of at least 5.25 inches<sup>2</sup> (3,387 mm<sup>2</sup>). Min. web thickness of 7/16 inch (11 mm).
- 5) Resilient Channels: Min. 0.019-inch (0.5-mm) Galvanized Resilient Channels. Attached perpendicular to the bottom flange of the I-joist with 1-5/8-inch (41-mm) Type S drywall screws. Channels are spaced a max. of 16 inches (406 mm) on center, are doubled at each wallboard end joint, and extend to the next joist beyond each joint.
- 6) Ceiling: One layer of 5/8-inch (16-mm) Type C Gypsum Wallboard. Installed with long dimension perpendicular to resilient channels and fastened with min. 1-inch (25-mm) Type S drywall screws spaced at 12 inches (305 mm) on center on intermediate joists and 8 inches (203 mm) on center at end joints, and 3/4 inch (19 mm) from wallboard edges and ends. The end joints of the wallboard must be staggered.
  - a) Finish: The face layer joints must be covered with tape and coated with joint compound. Screw heads must also be covered with joint compound.

**B. SOUND RATING<sup>(a,b)</sup>**

Joist/RC Spacing <sup>(c)</sup>	Without Gypsum Concrete				With 1-in. (25-mm) Gypsum Concrete			
	Cushioned Vinyl		Carpet & Pad		Cushioned Vinyl		Carpet & Pad	
	STC	IIC	STC	IIC	STC	IIC	STC	IIC
24"/16" o.c.	48 (51)	42 (43)	48 (51)	61 (63)	63 (65)	50 (52)	63 (65)	65 (67)
16"/16" o.c.	44 (46)	37 (39)	44 (46)	60 (61)	56 (57)	46 (47)	56 (57)	58 (59)

- <sup>(a)</sup> Sound ratings from the American Wood Council publication Design for Code Acceptance (DCA) 3, available from [www.awc.org](http://www.awc.org).  
<sup>(b)</sup> STC and IIC values established by engineering analysis based on 1.5-in. (38-mm) thick mineral wool batt insulation. Values in parentheses are based on 3.5-in. (89-mm) thick mineral wool batt insulation.  
<sup>(c)</sup> STC and IIC values for 16 in. (406 mm) o.c. joist spacing are applicable to 19.2-in. (488 mm) o.c. joist spacing.

**C. SIMILAR ASSEMBLIES**

- 1) 2015/2018/2021/2024 IBC Table 721.1(3) Item 25-1.1, and DCA 3 WIJ-1.2.
- 2) Assemblies that meet the fire-resistance rating in accordance with NBC Table 9.10.3.1.-B or the calculation method specified in NBC Appendix D-2.3.

\* This assembly may also be used in a fire-rated roof/ceiling assembly, but only when constructed exactly as described.

*REPRESENTING THE ENGINEERED WOOD INDUSTRY*



## Nordic Structures Assembly NEW1.3

### One-Hour Fire Resistance Rated Floor/Ceiling Assembly\*

This fire resistance design is listed in accordance with the International Building Code (IBC) and American Wood Council's Design for Code Acceptance (DCA) 3

**Min. 9-1/4 inches Deep (235 mm): NI-20, NI-40, NI-40x, NI-60, NI-70, NI-80, NI-80x, NI-90, and NI-90x I-Joists**

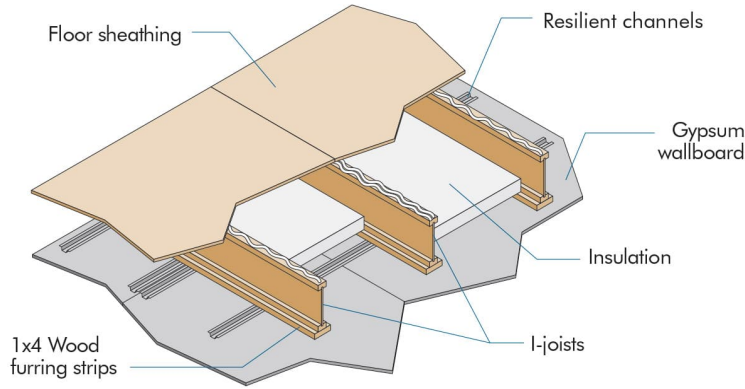

#### A. BASIC ASSEMBLIES

- 1) Floor Topping (Optional): Varies (reference sound ratings if applicable).
- 2) Floor Sheathing: Min. 23/32-inch (18-mm) T&G Wood Structural Panel. The sheets shall be installed with their long edge perpendicular to the joists with end joints centered over the top flange of joists. Floor sheathing must be installed per code requirements.
- 3) Insulation: Min. 2-inch (51-mm) Mineral Wool Insulation Batts (min. 3.5 pcf). Installed adjacent to the bottom flange of the I-joist and supported by 1x4 wood furring strip spacer. The ends of the batts shall be centered over resilient channels.
- 4) Structural Members: Min. 9-1/4 inches (235 mm) Deep I-Joists. Max. 24 inches (610 mm) on center spacing. Min. flange thickness of 1-5/16 inches (33 mm) and each flange area of at least 2.25 inches<sup>2</sup> (1,452 mm<sup>2</sup>). Min. web thickness of 3/8 inch (9.5 mm).
- 5) Wood Furring Strip Spacers: Min. nominal 1 inch (25 mm) x 4 inches (102 mm) attached with 1-1/2-inch (38-mm) long drywall screws at 24 inches (610 mm) on center along the bottom of the bottom flange of each I-joist.
- 6) Resilient Channels: Min. 0.019-inch (0.5-mm) Galvanized Resilient Channels (1/2-inch or 13-mm deep single leg). Attached perpendicular to the wood furring strip and bottom flange of the I-joist with 1-7/8 inch (48-mm) Type S drywall screws. Channels are spaced a max. of 16 inches (406 mm) on center, are doubled at each wallboard end joint, and extend to the next joint beyond each joint.
- 7) Ceiling: One layer of 5/8-inch (16-mm) Type C Gypsum Wallboard. Installed with long dimension perpendicular to resilient channels and fastened with min. 1-1/8-inch (29-mm) Type S drywall screws spaced at 7 inches (178 mm) on center, and 3/4 inch (19 mm) from wallboard edges and ends. The end joints of the wallboard must be staggered.
  - a) Finish: The face layer joints must be covered with tape and coated with joint compound. Screw heads must also be covered with joint compound.

#### B. SOUND RATING<sup>(a,b)</sup>

Joist/RC Spacing <sup>(c)</sup>	Without Gypsum Concrete				With 1-in. (25-mm) Gypsum Concrete			
	Cushioned Vinyl		Carpet & Pad		Cushioned Vinyl		Carpet & Pad	
	STC	IIC	STC	IIC	STC	IIC	STC	IIC
24"/16" o.c.	50 (51)	43 (43)	52	66	63 (65)	51 (52)	63 (65)	67 (67)
16"/16" o.c.	45 (46)	38 (39)	45 (46)	60 (61)	57 (57)	46 (47)	57 (57)	59 (59)

<sup>(a)</sup> Sound ratings from the American Wood Council publication Design for Code Acceptance (DCA) 3, available from [www.awc.org](http://www.awc.org).

<sup>(b)</sup> STC and IIC values established by engineering analysis based on 1.5-in. (38-mm) thick mineral wool batt insulation. Values in parentheses are based on 3.5-in. (89-mm) thick mineral wool batt insulation.

<sup>(c)</sup> STC and IIC values for 16 in. (406 mm) o.c. joist spacing are applicable to 19.2-in. (488 mm) o.c. joist spacing.

#### C. SIMILAR ASSEMBLIES

- 1) 2015/2018/2021/2024 IBC Table 721.1(3) Item 23-1.1, and DCA 3 WIJ-1.3.
- 2) Assemblies that meet the fire-resistance rating in accordance with NBC Table 9.10.3.1.-B or the calculation method specified in NBC Appendix D-2.3.

\* This assembly may also be used in a fire-rated roof/ceiling assembly, but only when constructed exactly as described.

REPRESENTING THE ENGINEERED WOOD INDUSTRY



Nordic Structures Assembly NEW1.4  
One-Hour Fire Resistance Rated Floor/Ceiling Assembly\*

This fire resistance design is listed in accordance with *American Wood Council's Design for Code Acceptance (DCA) 3*  
**Min. 9-1/4 inches Deep (235 mm): NI-20, NI-40, NI-40x, NI-60, NI-70, NI-80, NI-80x, NI-90, and NI-90x I-Joists**

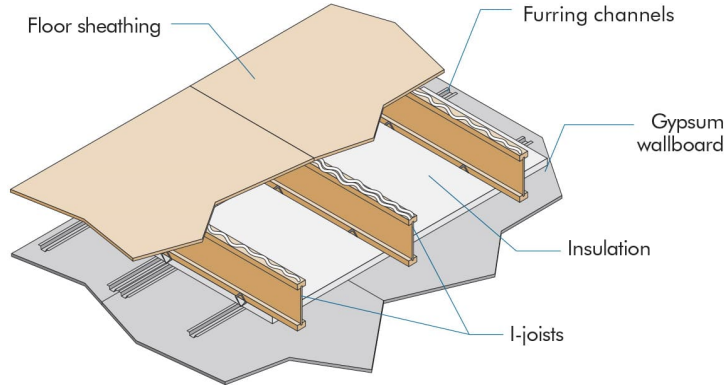

**A. BASIC ASSEMBLIES**

- 1) Floor Topping (Optional): Varies (reference sound ratings if applicable).
- 2) Floor Sheathing: Min. 23/32-inch (18-mm) T&G Wood Structural Panel. The sheets shall be installed with their long edge perpendicular to the joists with end joints centered over the top flange of joists. Floor sheathing must be installed per code requirements.
- 3) Insulation: Min. 1-inch (25-mm) Mineral Wool Insulation Batts (min. 6 pcf) with width equal to on-center spacing of the I-joists. Installed below the bottom flange of the I-joist and on top of furring channels with sides butted against support clips. The ends of the batts shall be centered over furring channels with batts tightly butted at all joints.
- 4) Structural Members: Min. 9-1/4 inches (235 mm) Deep I-Joists. Max. 24 inches (610 mm) on center spacing. Min. flange thickness of 1-1/2 inches (38 mm) and each flange area of at least 3.45 inches<sup>2</sup> (2,226 mm<sup>2</sup>). Min. web thickness of 3/8 inch (9.5 mm).
- 5) Furring Channels: Min. 0.019-inch (0.5-mm) Hat Shaped Galvanized Steel Channels attached perpendicular to the bottom flange of the I-joist with Simpson Type CSC support clips at each intersection with the I-joists. Clips nailed to the side of bottom flange with one 1-1/2-inch (38-mm) long No. 11 gage nail. Channels are spaced a max. of 24 inches (610 mm) on center, are doubled at each wallboard end joint, and extend to the next joist beyond each joint. At channel splices, adjacent pieces overlapped a minimum of 6 inches (152 mm) and tied with a double strand of No. 18 gage galvanized steel wire at each end of the overlap. A row of furring channel located on each side of wallboard end joints and spaced 2-1/4 inches (57 mm) from the end joint (4-1/2 inches or 114 mm on center).
- 6) Ceiling: One layer of 1/2-inch (13-mm) Type C Gypsum Wallboard. Installed with long dimension perpendicular to furring channels and fastened with min. 1-inch (25-mm) Type S drywall screws spaced at 12 inches (305 mm) on center on intermediate joists, 6 inches (152 mm) on center at end joints, and 3/4 inch (19 mm) from wallboard edges and ends. The end joints of the wallboard must be staggered and the furring channels must extend a min. of 6 inches (152 mm) beyond each end of the joint.
  - a) Finish: The face layer joints must be covered with tape and coated with joint compound. Screw heads must also be covered with joint compound.

**B. SOUND RATING<sup>(a,b)</sup>**

Joist/RC Spacing	Without Gypsum Concrete				With 3/4-in. (19-mm) Gypsum Concrete			
	Cushioned Vinyl		Carpet & Pad		Cushioned Vinyl		Carpet & Pad	
	STC	IIC	STC	IIC	STC	IIC	STC	IIC
24"/24" o.c.	--	--	46	68	51	47	50	73

<sup>(a)</sup> Sound ratings from the American Wood Council publication Design for Code Acceptance (DCA) 3, available from [www.awc.org](http://www.awc.org).

<sup>(b)</sup> STC and IIC values are based on tests of assemblies with 5/8-in. (15.9-mm) thick gypsum boards.

**C. SIMILAR ASSEMBLIES**

- 1) DCA 3 WIJ-1.4.
- 2) Assemblies that meet the fire-resistance rating in accordance with NBC Table 9.10.3.1.-B or the calculation method specified in NBC Appendix D-2.3.

\* This assembly may also be used in a fire-rated roof/ceiling assembly, but only when constructed exactly as described.

*REPRESENTING THE ENGINEERED WOOD INDUSTRY*



## Nordic Structures Assembly NEW1.5

### One-Hour Fire Resistance Rated Floor/Ceiling Assembly\*

This fire resistance design is listed in accordance with *American Wood Council's Design for Code Acceptance (DCA) 3*  
**Min. 9-1/4 inches Deep (235 mm): NI-20, NI-40, NI-40x, NI-60, NI-70, NI-80, NI-80x, NI-90, and NI-90x I-Joists**

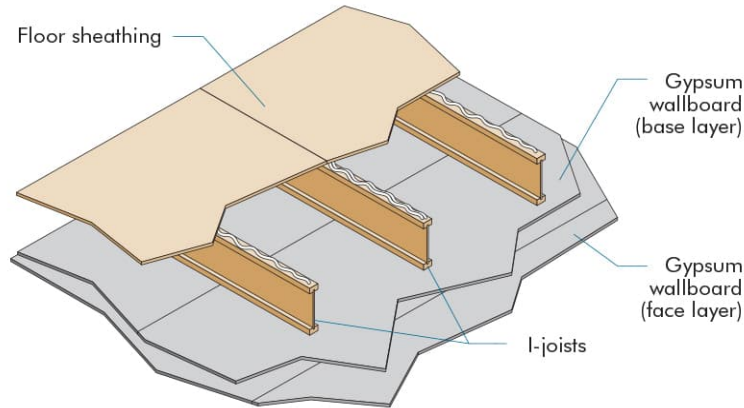

#### A. BASIC ASSEMBLIES

- 1) Floor Topping (Optional): Varies (reference sound ratings if applicable).
- 2) Floor Sheathing: Min. 23/32-inch (18-mm) T&G Wood Structural Panel. The sheets shall be installed with their long edge perpendicular to the joists with end joints centered over the top flange of joists. Floor sheathing must be installed per code requirements.
- 3) Structural Members: Min. 9-1/4 inches (235 mm) Deep I-Joists. Max. 24 inches (610 mm) on center spacing. Min. flange thickness of 1-1/2 inches (38 mm) and each flange area of at least 2.25 inches<sup>2</sup> (1,452 mm<sup>2</sup>). Min. web thickness of 3/8 inch (9.5 mm).
- 4) Ceiling: Two layers of 1/2-inch (13-mm) Type C Gypsum Wallboard.
  - a) Base Layer: Install with long dimension perpendicular to joist length. Attach to the bottom flange of the joists using 1-inch (25-mm) Type S drywall screws at 12 inches (305 mm) on center. The end joints of the wallboard must be centered on the bottom flange of the joist and must be staggered.
  - b) Face Layer: Install with long dimension perpendicular to joist length. Attach to the bottom flange of the joists through the base layer using 1-5/8-inch (41-mm) Type S drywall screws spaced at 12 inches (305 mm) on center on intermediate joists and 8 inches (203 mm) on center at end joints. The longitudinal joints of this layer must be offset 24 inches (610 mm) from those of the base layer. The end joints must be centered on the bottom flange of the joists and offset a min. of 48 inches (1219 mm) from those of the base layer. Additionally, face layer end joints are attached to the base layer with 1-1/2-inch (38-mm) Type G drywall screws at 8 inches (203 mm) on center with a 4-inch (102-mm) stagger, placed 6 inches (152 mm) either side of the joint.
  - c) Finish: The face layer joints must be covered with tape and coated with joint compound. Screw heads must also be covered with joint compound.

#### B. SOUND RATING<sup>(a,b)</sup>

Joist Spacing	Without Gypsum Concrete				With 3/4-in. (19-mm) Gypsum Concrete			
	Cushioned Vinyl		Carpet & Pad		Cushioned Vinyl		Carpet & Pad	
	STC	IIC	STC	IIC	STC	IIC	STC	IIC
24" o.c.	--	--	--	--	--	--	49	55

<sup>(a)</sup> Sound ratings from the American Wood Council publication *Design for Code Acceptance (DCA) 3*, available from [www.awc.org](http://www.awc.org).

<sup>(b)</sup> STC and IIC values are based on engineering analysis performed by David L. Adams Associates, Inc.

#### C. SIMILAR ASSEMBLIES

- 1) 2024 IBC Table 721.1(3) Item 31-1.1, and DCA 3 WIJ-1.5.
- 2) Assemblies that meet the fire-resistance rating in accordance with NBC Table 9.10.3.1.-B or the calculation method specified in NBC Appendix D-2.3.

\* This assembly may also be used in a fire-rated roof/ceiling assembly, but only when constructed exactly as described.

REPRESENTING THE ENGINEERED WOOD INDUSTRY



## Nordic Structures Assembly NEW1.6

### One-Hour Fire Resistance Rated Floor/Ceiling Assembly\*

This fire resistance design is listed in accordance with *American Wood Council's Design for Code Acceptance (DCA) 3*  
**Min. 9-1/2 inches Deep (241 mm): NI-20, NI-40, NI-40x, NI-60, NI-70, NI-80, NI-80x, NI-90, and NI-90x I-Joists**

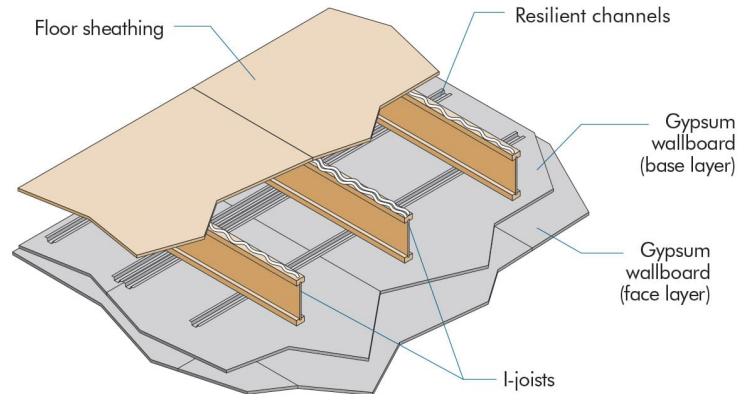

#### A. BASIC ASSEMBLIES

- 1) Floor Topping (Optional): Varies (reference sound ratings if applicable).
- 2) Floor Sheathing: Min. 23/32-inch (18-mm) T&G Wood Structural Panel. The sheets shall be installed with their long edge perpendicular to the joists with end joints centered over the top flange of joists. Floor sheathing must be installed per code requirements.
- 3) Structural Members: Min. 9-1/2 inches (241 mm) Deep I-Joists. Max. 24 inches (610 mm) on center spacing. Min. flange thickness of 1-5/16 inches (33 mm) and each flange area of at least 1.95 inches<sup>2</sup> (1,258 mm<sup>2</sup>). Min. web thickness of 3/8 inch (9.5 mm).
- 4) Resilient Channels†: Min. 0.019-inch (0.5-mm) Galvanized Resilient Channels. Attached perpendicular to the bottom flange of the I-joist with 1-1/4-inch (32-mm) Type S drywall screws. Channels are spaced a max. of 16 inches (406 mm) on center (24 inches or 610 mm when I-joists are spaced a max. of 16 inches or 406 mm on center), are doubled at each base layer wallboard end joint, and extend to the next joist beyond each joint.
- 5) Ceiling: Two layers of 1/2-inch (13-mm) Type X Gypsum Wallboard.
  - a) Base Layer: Install with long dimension perpendicular to resilient channels. Attach to the resilient channels using 1-1/4-inch (32-mm) Type S drywall screws at 12 inches (305 mm) on center. The end joints of the wallboard must be staggered.
  - b) Face Layer: Install with long dimension perpendicular to resilient channels. Attach to the resilient channels through the base layer using 1-5/8-inch (41-mm) Type S drywall screws spaced at 12 inches (305 mm) on center. The longitudinal joints of this layer must be offset 24 inches (610 mm) from those of the base layer. Additionally, face layer end joints are attached to the base layer with 1-1/2-inch (38-mm) Type G drywall screws at 8 inches (203 mm) on center placed 1-1/2 inches (38 mm) either side of the joint.
  - c) Finish: The face layer joints must be covered with tape and coated with joint compound. Screw heads must also be covered with joint compound.

#### B. SOUND RATING<sup>(a,b)</sup>

Joist/RC Spacing <sup>(c)</sup>	Without Gypsum Concrete				With 1-in. (25-mm) Gypsum Concrete			
	Cushioned Vinyl		Carpet & Pad		Cushioned Vinyl		Carpet & Pad	
	STC	IIC	STC	IIC	STC	IIC	STC	IIC
24"/16" o.c.	46	44	46	61	58	47 (51)	58	67
16"/24" o.c.	47	43	47	64	60	49 (52)	60	67

<sup>(a)</sup> Sound ratings from the American Wood Council publication Design for Code Acceptance (DCA) 3, available from [www.awc.org](http://www.awc.org).

<sup>(b)</sup> STC and IIC values established by engineering analysis. Values in parentheses are based on laminate wood flooring over a 0.08-in. (2-mm) closed-cell foam underlay, in lieu of cushioned vinyl flooring.

<sup>(c)</sup> STC and IIC values for 16 in. (406 mm) o.c. joist spacing are applicable to 19.2-in. (488 mm) o.c. joist spacing.

#### C. SIMILAR ASSEMBLIES

- 1) 2015/2018/2021/2024 IBC Table 721.1(3) Item 27-1.1, and DCA 3 WIJ-1.6.
- 2) Assemblies that meet the fire-resistance rating in accordance with NBC Table 9.10.3.1.-B or the calculation method specified in NBC Appendix D-2.3.

\* This assembly may also be used in a fire-rated roof/ceiling assembly, but only when constructed exactly as described.

† Direct attachment of gypsum wallboard in lieu of attachment to resilient channels is typically deemed acceptable. When gypsum wallboard is directly attached to the I-joists, the wallboard shall be installed with the long dimension perpendicular to the I-joists and sound rating for NEW1.5 Assembly shall be used.

REPRESENTING THE ENGINEERED WOOD INDUSTRY



## Nordic Structures Assembly NEW1.7

### One-Hour Fire Resistance Rated Floor/Ceiling Assembly\*

This fire resistance design is listed in accordance with *American Wood Council's Design for Code Acceptance (DCA) 3*  
**Min. 9-1/2 inches Deep (241 mm): NI-20, NI-40, NI-40x, NI-60, NI-70, NI-80, NI-80x, NI-90, and NI-90x I-Joists**

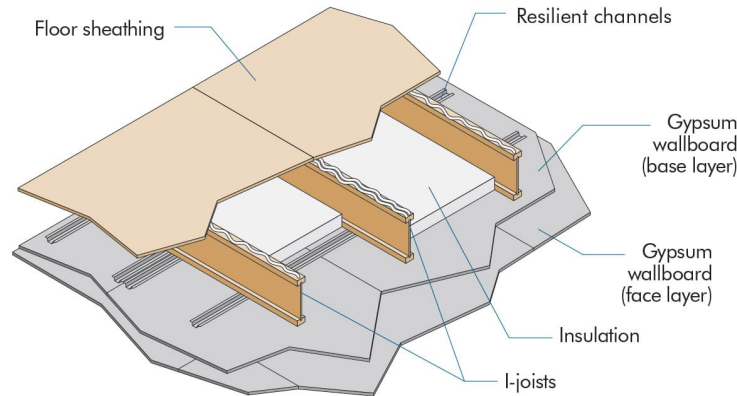

#### A. BASIC ASSEMBLIES

- 1) Floor Topping (Optional): Varies (reference sound ratings if applicable).
- 2) Floor Sheathing: Min. 23/32-inch (18-mm) T&G Wood Structural Panel. The sheets shall be installed with their long edge perpendicular to the joists with end joints centered over the top flange of joists. Floor sheathing must be installed per code requirements.
- 3) Insulation: Glass Fiber Insulation. Installed between I-joists and supported by resilient channels.
- 4) Structural Members: Min. 9-1/2 inches (241 mm) Deep I-Joists. Max. 24 inches (610 mm) on center spacing. Min. flange thickness of 1-1/2 inches (38 mm) and each flange area of at least 2.25 inches<sup>2</sup> (1,452 mm<sup>2</sup>). Min. web thickness of 3/8 inch (9.5 mm).
- 5) Resilient Channels: Min. 0.019-inch (0.5-mm) Galvanized Resilient Channels. Attached perpendicular to the bottom flange of the I-joist with 1-1/4 inch (32-mm) Type S drywall screws. Channels are spaced a max. of 16 inches (406 mm) on center (24 inches or 610 mm when I-joists are spaced a max. of 16 inches or 406 mm on center), are doubled at each base layer wallboard end joint, and extend to the next joist beyond each joint.
- 6) Ceiling: Two layers of 1/2-inch (13-mm) Type X Gypsum Wallboard.
  - a) Base Layer: Install with long dimension perpendicular to resilient channels. Attach to the resilient channels using 1-1/4-inch (32-mm) Type S drywall screws at 12 inches (305 mm) on center. The end joints of the wallboard must be staggered.
  - b) Face Layer: Install with long dimension perpendicular to resilient channels. Attach to the resilient channels through the base layer using 1-5/8-inch (41-mm) Type S drywall screws spaced at 12 inches (305 mm) on center. The longitudinal joints of this layer must be offset 24 inches (610 mm) from those of the base layer. Additionally, face layer end joints are attached to the base layer with 1-1/2-inch (38-mm) Type G drywall screws at 8 inches (203 mm) on center placed 1-1/2 inches (38 mm) either side of the joint.
  - c) Finish: The face layer joints must be covered with tape and coated with joint compound. Screw heads must also be covered with joint compound.

#### B. SOUND RATING<sup>(a,b)</sup>

Joist/RC Spacing <sup>(c)</sup>	Without Gypsum Concrete				With 1-in. (25-mm) Gypsum Concrete			
	Cushioned Vinyl		Carpet & Pad		Cushioned Vinyl		Carpet & Pad	
	STC	IIC	STC	IIC	STC	IIC	STC	IIC
24"/16" o.c.	56	51	56	69	64	53	64	71
16"/24" o.c.	55	48 (51)	55	67	64	54	64	67

<sup>(a)</sup> Sound ratings from the American Wood Council publication Design for Code Acceptance (DCA) 3, available from [www.awc.org](http://www.awc.org).

<sup>(b)</sup> STC and IIC values established by engineering analysis based on 3.5-in. (89-mm) thick glass fiber insulation. Values in parentheses are based on laminate wood flooring over a 0.08-in. (2-mm) closed-cell foam underlay, in lieu of cushioned vinyl flooring.

<sup>(c)</sup> STC and IIC values for 16 in. (406 mm) o.c. joist spacing are applicable to 19.2-in. (488 mm) o.c. joist spacing.

#### C. SIMILAR ASSEMBLIES

- 1) 2015/2018/2021/2024 IBC Table 721.1(3) Item 30-1.1, and DCA 3 WIJ-1.7.
- 2) Assemblies that meet the fire-resistance rating in accordance with NBC Table 9.10.3.1.-B or the calculation method specified in NBC Appendix D-2.3.

\* This assembly may also be used in a fire-rated roof/ceiling assembly, but only when constructed exactly as described.

REPRESENTING THE ENGINEERED WOOD INDUSTRY





## Nordic Structures Assembly NEW1.8

### One-Hour Fire Resistance Rated Floor/Ceiling Assembly\*

This fire resistance design is listed in accordance with the International Building Code (IBC)

**Min. 9-1/4 inches Deep (235 mm): NI-20, NI-40, NI-40x, NI-60, NI-70, NI-80, NI-80x, NI-90, and NI-90x I-Joists**

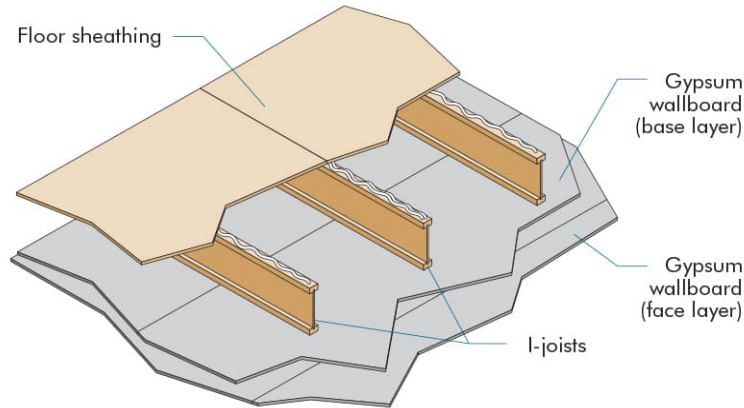

#### A. BASIC ASSEMBLIES

- 1) Floor Topping (Optional): Varies (reference sound ratings if applicable).
- 2) Floor Sheathing: Min. 23/32-inch (18-mm) T&G Wood Structural Panel. The sheets shall be installed with their long edge perpendicular to the joists with end joints centered over the top flange of joists. Floor sheathing must be installed per code requirements.
- 3) Structural Members: Min. 9-1/4 inches (235 mm) Deep I-Joists. Max. 24 inches (610 mm) on center spacing. Min. flange thickness of 1-1/2 inches (38 mm) and each flange area of at least 2.25 inches<sup>2</sup> (1,452 mm<sup>2</sup>). Min. web thickness of 3/8 inch (9.5 mm).
- 4) Ceiling: Two layers of 1/2-inch (13-mm) Type X Gypsum Wallboard.
  - a) Base Layer: Install with long dimension perpendicular to joist length. Attach to the bottom flange of the joists using 1-5/8-inch (41-mm) Type S drywall screws at 12 inches (305 mm) on center. The end joints of the wallboard must be centered on the bottom flange of the joist and must be staggered the equivalent of two joist spacings with those of adjacent sheets.
  - b) Face Layer: Install with long dimension perpendicular to joist length. Attach to the bottom flange of the joists through the base layer using 2-inch (51-mm) Type S drywall screws spaced at 12 inches (305 mm) on center on intermediate joists and 8 inches (203 mm) on center at end joints. Face layer end joint must not occur on the same joist as base layer end joints. The longitudinal joints of this layer must be offset 24 inches (610 mm) from those of the base layer. Additionally, face layer end joints are attached to the base layer with 1-1/2-inch (38-mm) Type G drywall screws at 8 inches (203 mm) on center placed 6 inches (152 mm) either side of the joint.
  - c) Finish: The face layer joints must be covered with tape and coated with joint compound. Screw heads must also be covered with joint compound.

#### B. SOUND RATING

Information not available.

#### C. SIMILAR ASSEMBLIES

- 1) 2015/2018/2021/2024 IBC Table 721.1(3) Item 26-1.1.
- 2) Assemblies that meet the fire-resistance rating in accordance with NBC Table 9.10.3.1.-B or the calculation method specified in NBC Appendix D-2.3.

\* This assembly may also be used in a fire-rated roof/ceiling assembly, but only when constructed exactly as described.

REPRESENTING THE ENGINEERED WOOD INDUSTRY



## Nordic Structures Assembly NEW1.9

### One-Hour Fire Resistance Rated Floor/Ceiling Assembly\* †

This fire resistance design is listed in accordance with the ASTM E119 and CAN/ULC S101

**Min. 9-1/2 inches (241 mm) Deep: NI-20, NI-40, NI-40x, NI-60, NI-70, NI-80, NI-80x, NI-90, and NI-90x I-Joists**

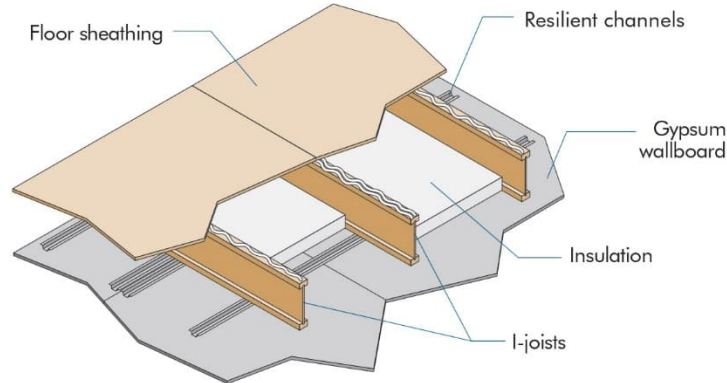

#### A. BASIC ASSEMBLIES

- 1) Floor Topping (Optional): Varies (reference sound ratings if applicable).
- 2) Floor Sheathing: Min. 23/32-inch (18-mm) T&G Wood Structural Panel. A construction adhesive must be applied to the top of the joists prior to placing sheathing. The sheets shall be installed with their long edge perpendicular to the joists with end joints centered over the top flange of joists. Floor sheathing must be installed per code requirements.
- 3) Insulation: Min. 3-1/2-inch (89-mm) Fiber Glass Insulation (R13). Installed adjacent to the bottom flange of the I-joist and supported by the resilient channels.
- 4) Structural Members: Min. 9-1/2-inch (241-mm) Deep I-Joists. Max. 24 inches (610 mm) on center spacing. Min. flange thickness of 1-1/2 inches (38 mm) and each flange area of at least 3.75 inches<sup>2</sup> (2,419 mm<sup>2</sup>). Min. web thickness of 3/8 inch (9.5 mm).
- 5) Resilient Channels: Min. 0.019-inch (0.5-mm) Galvanized Resilient Channels. Attached perpendicular to the bottom flange of the I-joist with 1-1/4-inch (32-mm) Type W drywall screws. Channels are spaced a max. of 16 inches (406 mm) on center, are doubled at each wallboard end joint, and extend to the next joist beyond each joint.
- 6) Ceiling: One layer of 3/4-inch (19-mm) Type X Gypsum Wallboard with a minimum weight of 3.0 lbf/ft<sup>2</sup> (14.6 kg/m<sup>2</sup>) in compliance with ASTM C1396. Installed with long dimension perpendicular to resilient channels and fastened with min. 1-1/8-inch (29-mm) Type S drywall screws spaced at 8 inches (203 mm) on center, and 1 inch (25 mm) from wallboard edges and 1-1/2 inches (38 mm) from wallboard ends. The end joints of the wallboard must be staggered.
  - a) Finish: The face joints must be covered with tape and coated with joint compound. Screw heads must also be covered with joint compound.

#### B. SOUND RATING<sup>(a)</sup>

Components	STC	IIC
Base Assembly with cushioned vinyl	52	44
Base Assembly with Carpet and Padding	52	64
Base Assembly with cushioned vinyl, Gypsum Concrete	64	53
Base Assembly with Carpet and Padding, Gypsum Concrete	64	68

<sup>(a)</sup> Sound ratings determined from engineering analysis using AWC Technical Report 15, Calculation of Sound Transmission Parameters for Wood-Frame Assemblies in accordance with Section 1206.2 of the 2024/2021/2018 IBC.

#### C. SIMILAR ASSEMBLIES

- 1) Assemblies that meet the fire-resistance rating in accordance with NBC Table 9.10.3.1.-B or the calculation method specified in NBC Appendix D-2.3.

\* This assembly may also be used in a fire-rated roof/ceiling assembly, but only when constructed exactly as described.

† Authorization for use by APA – The Engineered Wood Association.

REPRESENTING THE ENGINEERED WOOD INDUSTRY



## Nordic Structures Assembly NEW2.1

### Two-Hour Fire Resistance Rated Floor/Ceiling Assembly\*

This fire resistance design is listed in accordance with the International Building Code (IBC) and American Wood Council's Design for Code Acceptance (DCA) 3

**Min. 9-1/4 inches Deep (235 mm): NI-20, NI-40, NI-40x, NI-60, NI-70, NI-80, NI-80x, NI-90, and NI-90x I-Joists**

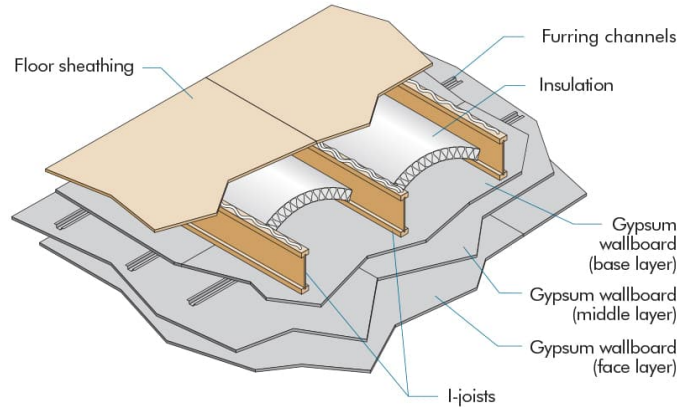

#### A. BASIC ASSEMBLIES

- 1) Floor Topping (Optional): Varies (reference sound ratings if applicable).
- 2) Floor Sheathing: Min. 23/32-inch (18-mm) T&G Wood Structural Panel. The sheets shall be installed with their long edge perpendicular to the joists with end joints centered over the top flange of joists. Floor sheathing must be installed per code requirements.
- 3) Insulation: 3-1/2-inch (89-mm) Unfaced Glass Fiber Insulation. Friction fitted between I-joists and supported by stay wires spaced 12 inches (305 mm) on center along the top of the I-joist bottom flange.
- 4) Structural Members: Min. 9-1/4 inches (235 mm) Deep I-Joists. Max. 24 inches (610 mm) on center spacing. Min. flange thickness of 1-1/2 inches (38 mm) and each flange area of at least 2.25 inches<sup>2</sup> (1,452 mm<sup>2</sup>). Min. web thickness of 3/8 inch (9.5 mm).
- 5) Furring Channels: Min. 0.0179-inch (0.45-mm) Hat Shaped Galvanized Steel Channels attached perpendicular to the bottom flange of the I-joist with 1-5/8-inch (41-mm) Type S drywall screws penetrating through the wallboard base layer into each I-joist flange. Channels are spaced a max. of 16 inches (406 mm) on center, are doubled at each base layer wallboard end joint, and extend to the next joist beyond each joint.
- 6) Ceiling: Three layers of 5/8-inch (16-mm) Type C Gypsum Wallboard.
  - a) Base Layer: Install with long dimension perpendicular to joist length. Attach to the bottom flange of the joists using 1-5/8-inch (41-mm) Type S drywall screws at 12 inches (305 mm) on center. The end joints of the wallboard must be centered on the bottom flange of the I-joist and must be staggered.
  - b) Middle Layer: Attached to furring channels using 1-inch (25-mm) Type S drywall screws at 12 inches (305 mm) on center with the long dimension perpendicular to furring channels. End joints must be staggered from end joints of adjacent sheets and end joints on the face layer.
  - c) Face Layer: Attached to furring channels through the middle layer using 1-5/8-inch (41-mm) Type S drywall screws spaced at 8 inches (203 mm) on center with long dimension perpendicular to furring channel. End joints must be staggered from end joints of adjacent sheets and staggered from end joints on the middle layer. Edge joints (long dimension) must be offset 24 inches (610 mm) from those of the middle layer.
  - d) Finish: The face layer joints must be covered with tape and coated with joint compound. Screw heads must also be covered with joint compound.

#### B. SOUND RATING (with Resilient Channels)<sup>(a,b)</sup>

Joist/RC Spacing	Without Gypsum Concrete				With 1-in. (25-mm) Gypsum Concrete			
	Cushioned Vinyl		Carpet & Pad		Cushioned Vinyl		Carpet & Pad	
	STC	IIC	STC	IIC	STC	IIC	STC	IIC
24"/16" o.c.	--	--	49	54	58	45	58	64

<sup>(c)</sup> Sound ratings from the American Wood Council publication Design for Code Acceptance (DCA) 3, available from [www.awc.org](http://www.awc.org).

<sup>(d)</sup> STC and IIC values are based on engineering analysis performed by David L. Adams Associates, Inc.

#### C. SIMILAR ASSEMBLIES

- 1) 2015/2018/2021/2024 IBC Table 721.1(3) Item 28-1.1, and DCA 3 WIJ-2.1.
- 2) Assemblies that meet the fire-resistance rating in accordance with NBC Table 9.10.3.1.-B or the calculation method specified in NBC Appendix D-2.3.

\* This assembly may also be used in a fire-rated roof/ceiling assembly, but only when constructed exactly as described.

REPRESENTING THE ENGINEERED WOOD INDUSTRY



Fire Protection of Floors (FP-11) for Compliance with 2015, 2018, 2021, and 2024 IRC  
Section R302.13

**Fire Protection: 7/16 or Thicker Wood Structural Panel for Web Protection**

The following fire resistance design is an alternative to the 2-by-10 dimension lumber prescribed in 2015/2018/2021/2024 IRC Section R302.13 Exception 4, with demonstrated equivalent fire performance

**Min. 9-1/2 inches (241 mm) Deep: NI-20, NI-40, NI-40x, NI-60, NI-70, NI-80, NI-80x, NI-90, and NI-90x I-Joists**

**7/16 in. (11 mm) or Thicker Wood Structural Panel for Web Protection <sup>(a,b,d)</sup>**

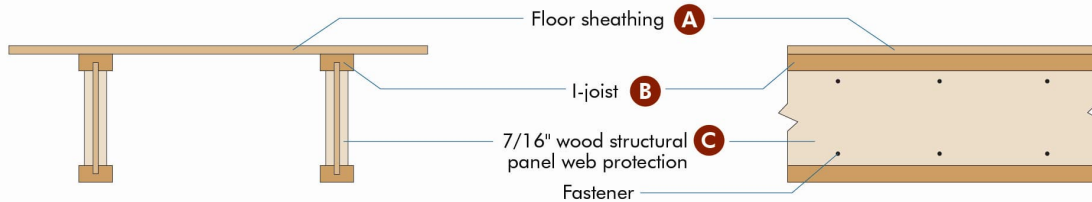

**Installation Requirements at Web Holes**

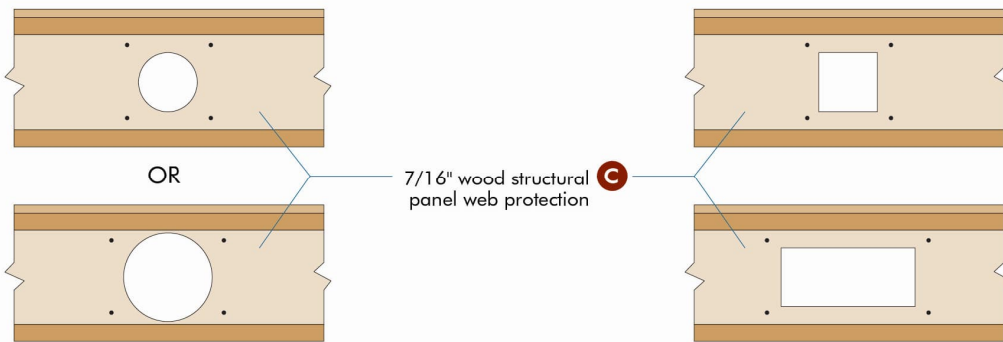

**Crawl Space Exception<sup>(b)</sup>**

In accordance with Exception 2 of the 2015/2018/2021/2024 IRC Section R302.13, floor assemblies located directly over a crawl space not intended for storage or fuel-fired appliances do not require wood structural panel fire protection.

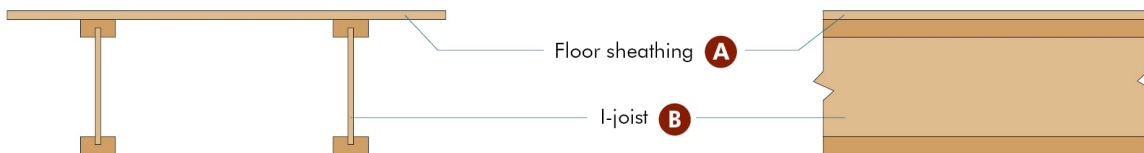

**Automatic Sprinkler Exception<sup>(c)</sup>**

In accordance with Exception 1 of the 2015/2018/2021/2024 IRC Section R302.13, floor assemblies located directly over a space protected by an automatic sprinkler system do not require wood structural panel fire protection.

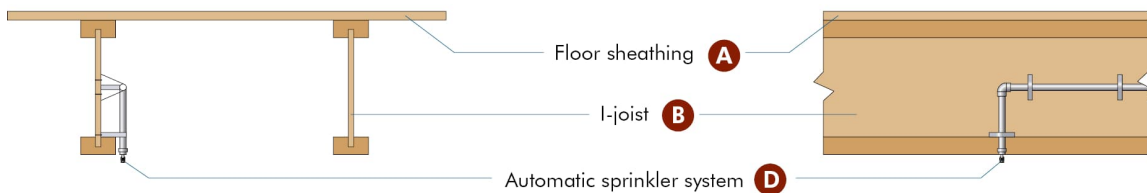

(Continued next page)

REPRESENTING THE ENGINEERED WOOD INDUSTRY



**(FP-11 Continued)**

- (A) Floor sheathing: Materials and installation in accordance with 2015, 2018, 2021, and 2024 IRC Section R503.
- (B) I-joist: Installation in accordance with Section 4 of this report. Maximum 24 inches (610 mm) on center spacing. Minimum flange size of 1-1/2 inches (38 mm) thick x 2-1/2 (63 mm) inches wide. Minimum web thickness of 3/8 inch (9.5 mm). Adhesives used shall be as described in the quality manual approved by APA. At each hole location, the 7/16 in. (11 mm) or thicker wood structural panels shall be cut with the web hole on both sides of the I-joist to allow the passage of a wire, pipe, or duct, in accordance with the web hole requirements permitted in the I-joist product report.
- (C) Wood structural panel (WSP) for web protection: Min. 7/16 Performance Category in compliance with DOC PS 1 or PS 2. The WSP shall continuously cover the entire length of the I-joist web on both sides. The panel-to-panel joints shall be tight with a joint gap of 1/16 inch (1.6 mm) or less and not required to be finished with tape or joint compound. Fasteners: Each WSP shall be fastened with 2 rows of 1/2 inch x 1 inch (12.7 mm x 25.4 mm) construction staples at 9 inches (229 mm) on center and 1 inch (25.4 mm) from the flange edge. Fasteners may be staggered from top to bottom. At hole location, fasteners shall be installed 1 inch (25.4 mm) from the edge of the hole, top and bottom.
- (D) Automatic sprinkler system: System in accordance with Section P2904 of the 2015, 2018, 2021, and 2024 IRC, NFPA 13D, or other equivalent sprinkler systems.

Notes:

- (a) In accordance with Exception 3 of 2015/2018/2021/2024 IRC Section R302.13, portions of floor assembly can be unprotected when complying with the following:
  - 1) The aggregate area of the unprotected portions shall not exceed 80 square feet (7.4 m<sup>2</sup>).
  - 2) Fire blocking in accordance with 2015, 2018, 2021, and 2024 IRC Section R302.11.1 shall be installed along the perimeter of the unprotected portion to separate the unprotected portion from the remainder of the floor assembly.
- (b) Insulation may be required for energy code compliance purposes. Check with the local building official for specific jurisdictional requirements.
- (c) In accordance with 2015, 2018, 2021, and 2024 IRC Section P2904, partial residential sprinkler systems are permitted to be installed only when the entire dwelling unit is not required to be equipped with a residential sprinkler system. Check with the local building official for specific jurisdictional requirements.
- (d) Penetrations or openings for ducts, vents, electrical outlets, lighting, devices, luminaires, wires, speakers, drainage, piping and similar openings or penetrations shall be permitted.

*APA – The Engineered Wood Association* is an approved national standards developer accredited by American National Standards Institute (ANSI). APA publishes ANSI standards and Voluntary Product Standards for wood structural panels and engineered wood products. APA is an accredited certification body under ISO/IEC 17065 by Standards Council of Canada (SCC), an accredited inspection agency under ISO/IEC 17020 by ANSI National Accreditation Board (ANAB), and an accredited testing organization under ISO/IEC 17025 by ANAB. APA is also an approved Product Certification Agency, Testing Laboratory, Quality Assurance Entity, Validation Entity, and Product Evaluation Entity by the State of Florida, and an approved testing laboratory by City of Los Angeles.

**APA – THE ENGINEERED WOOD ASSOCIATION  
HEADQUARTERS**

7011 So. 19<sup>th</sup> St. ▪ Tacoma, Washington 98466  
Phone: (253) 565-6600 ▪ Fax: (253) 565-7265 ▪ Internet Address: [www.apawood.org](http://www.apawood.org)

**PRODUCT SUPPORT HELP DESK**  
(253) 620-7400 ▪ E-mail Address: [help@apawood.org](mailto:help@apawood.org)

**DISCLAIMER**

APA Product Report® is a trademark of *APA – The Engineered Wood Association*, Tacoma, Washington. The information contained herein is based on the product evaluation in accordance with the references noted in this report. Neither APA, nor its members make any warranty, expressed or implied, or assume any legal liability or responsibility for the use, application of, and/or reference to opinions, findings, conclusions, or recommendations included in this report. Consult your local jurisdiction or design professional to assure compliance with code, construction, and performance requirements. Because APA has no control over quality of workmanship or the conditions under which engineered wood products are used, it cannot accept responsibility for product performance or designs as actually constructed.